



35W HIGH-VOLTAGE DC/DC CONVERTER

Single, Dual and Dual Isolated Outputs

Key Features

- Efficiency up to 91%
- 2:1 input voltage range
- Input under/overvoltage protection
- Input-to-output isolation
- Soft start
- Dual short circuit protection
- 500 μ A off state current
- Multiple converter synchronization
- Adjustable outputs
- 170kHz switching frequency
- Thermal protection
- Dual isolated outputs
- Six-sided shielding



Beta Dyne is protected under various patents, including but not limited to U.S. Patent numbers: 5,777,519; 6,188,276; 6,262,901; 6,452,818; 6,473,3171.

Applications

- Telecom
- Micro-Mirror Drivers
- DSL Systems
- Remote Feed Systems
- Battery Power Systems
- High Voltage Power OPAMs
- Transducer Drivers

Functional Description

The 35W high-voltage series of DC/DC converters are specifically designed for telecommunications applications including xDSL remote power feed. These converters offer a wide input voltage range with nominal inputs of 12, 24, 48 and 120V_{IN}. Outputs can be single or dual and can be set as two adjustable isolated outputs of 120, \pm 120 or 240V_{OUT}. Additional features include total input-to-output isolation, short circuit and thermal protection, soft start, under/overvoltage protection, adjustable outputs, and efficiency up to 91%.

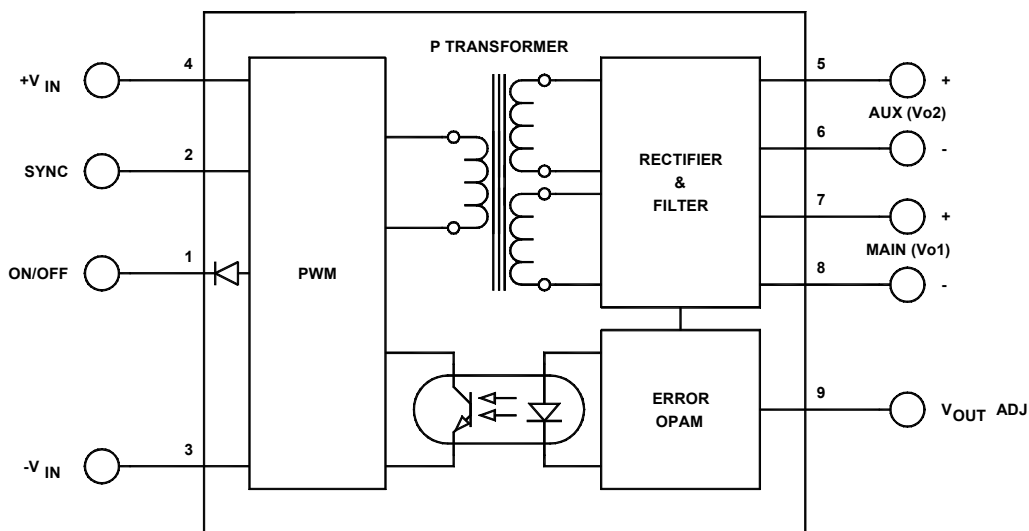

Typical Block Diagram

Electrical Specifications

Unless otherwise specified, all parameters are given under typical +25°C with nominal input voltage and under full output load conditions.

INPUT SPECIFICATIONS

PARAMETER	CONDITION / NOTE	MIN	TYP	MAX	UNIT
Input Voltage Range	See Model Selection Guide				
Input Startup Voltage, 12V _{IN}		10.5	11		Vdc
Input Startup Voltage, 24V _{IN}		17	18		Vdc
Input Startup Voltage, 48V _{IN}		35	36		Vdc
Input Startup Voltage, 120V _{IN}		74	75		Vdc
Input Overvoltage Protection, 12V _{IN}		19	20		Vdc
Input Overvoltage Protection, 24V _{IN}		37	38		Vdc
Input Overvoltage Protection, 48V _{IN}		74	76		Vdc
Input Overvoltage Protection, 120V _{IN}		145			Vdc
Input Filter	Pi (π)				
Reverse Polarity ¹ 	External series-blocking diode				
Reflected Ripple	I _o = FL, C _{IN} = 10μF, See Model Selection Guide				
No Load Input Current	See Model Selection Guide				
Input Surge Current (20μS Spike)				10	A
Short Circuit Current Limit	See Short Circuit Protection		150		% I _N
Off State Current			500		μA
Remote ON/OFF Control					
Supply ON	Pin 1 Open (Open circuit voltage: 13V max.)				
Supply OFF		0		0.8	Vdc
Logic Input Reference	-Input for ON/OFF and SYNC				
Logic Compatibility for Reference	TTL Open Collector or CMOS Open Drain				
Sync, High	See External Synchronization, Figure 6	2		6	Vdc
Sync, Low	See External Synchronization, Figure 6	0		0.8	Vdc

OUTPUT SPECIFICATIONS

PARAMETER	CONDITION / NOTE	MIN	TYP	MAX	UNIT
Output Voltage	See Model Selection Guide				
Output Voltage Accuracy			±1	±2	%
Ripple & Noise	(See App. Note DC-003)		1	2	%V _{PP} of V _{OUT}
Output Current	See Model Selection Guide				
Line Regulation, Single and Dual			±0.5	±1	%
Line Regulation, Dual Isolated Outputs	V _{o2} only (For V _{o1} , see Single and Dual)		±3	±5	%
Load Regulation, Single			±1	±2	%
Load Regulation, Dual ²	With balanced loads		±1	±2	%
Dual Isolated Outputs ³	Outputs fully loaded, See Figure 3		±3	±5	%
Temperature Coefficient @ FL			0.02		%/°C
Transient Response Time	50% FL to FL to 50% FL		200	250	μS
Short Circuit Protection	By input current limiting				
Output Adjust Range	(See App. Note DC-010)	±5		±10	%

GENERAL SPECIFICATIONS

PARAMETER	CONDITION / NOTE	MIN	TYP	MAX	UNIT
Efficiency	See Model Selection Guide				
Isolation Voltage (1 min.), Input to Output			1500		Vdc
Isolation Voltage (1 min.), Output to Output			500		Vdc
Isolation Resistance			10 ⁹		Ω
Isolation Capacitance			2700		pF
Switching Frequency			170		kHz
Turn On Delay	See Figure 8		7	10	mS
Soft Start Time	See Figure 8		7	15	mS

ENVIRONMENTAL SPECIFICATIONS

PARAMETER	CONDITION / NOTE	MIN	TYP	MAX	UNIT
Operating Temperature Range (Ambient)*	See Figure 4	-40		+71	°C
Storage Temperature Range		-55		+125	°C
Thermal Resistance	°C per watt internally dissipated		7		°C/W _{DISS}
Maximum Operating Case Temperature				110	°C
Derating	See Figure 4				
Cooling	Free-air convection				
EM/RFI	Six-sided continuous shielded metal case				
MTBF	per MIL-HNBK-217F (Ground benign, +25°C)		1.1×10 ⁶		hours
Humidity	Up to 95% non-condensing				
Thermal Shutdown	Case Temperature		110	115	°C
Thermal Hysteresis		2	5		°C

* See footnotes 4, 5, 7 and 8

PHYSICAL CHARACTERISTICS

PARAMETER	CONDITION / NOTE	MIN	TYP	MAX	UNIT
Dimensions (L×W×H)	2.00×2.00×0.50 in. (50.80×50.80×12.70mm)				
Weight	2.43 oz. (69g)				
Case Material	Coated metal				
Shielding Connection, 12, 24V _{IN}	-V _{IN} (Pin 3)				
Shielding Connection, 48, 120V _{IN}	+V _{IN} (Pin 4)				

Model Selection Guide

MODEL NUMBER	INPUT				Reflected Ripple ⁶ (mA _{PP})	OUTPUT		
	Voltage (Vdc)		Current (mA)			Voltage (Vdc)	Current (mA)	Efficiency Full Load (%)
	Nominal	Range	No Load	Full Load ⁵				
35S120/12 ⁹	12	10.5–18	50	2282	50 (with C ₁ =100μF)	120	192	84
35S120/24 ⁹	24	18–36	30	1676	100	120	292	87
35S120/48	48	36–72	20	820	100	120	292	89
35S120/120	120	75–140	15	320	100	120	292	91
35D120/12 ⁹	12	10.5–18	50	2282	50 (with C ₁ =100μF)	±120	±96	84
35D120/24	24	18–36	30	1676	100	±120	±146	87
35D120/48	48	36–72	20	820	100	±120	±146	89
35D120/120	120	75–140	15	320	100	±120	±146	91

¹ ⚠ WARNING - Usage of input fuse with adequate ratings is essential to avoid possible hazard and damage of the unit. A suppressor diode with adequate ratings is intended to be connected in series to the supply for reverse polarity protection.

² Pins 6 and 7 are connected internally.

³ A dual isolated output converter is generated from the single output converter by floating V_{O2} (see Figure 3). A 10% minimum load is required.

⁴ Contact factory for -55° to +85°C operating temperature range.

⁵ The maximum input current at any given input range measured at minimum input voltage is given as 1.6*I_{NOMINAL}. Nominal input current is the typical value measured at the input of the converter under full-load room temperature and nominal input voltage (12, 24, 48, and 120Vdc).

⁶ Measured with 10μF capacitor at the input power pins.

⁷ Adequate insulation is to be provided to the converters at the end usage as per applicable requirements.

⁸ Temperature rise on the case of the converters is to be considered during the end usage as per applicable requirements.

⁹ For 12V_{IN} and 24V_{IN} models, derate the converter above 50°C ambient (see Figure 4).

ORDERING GUIDE

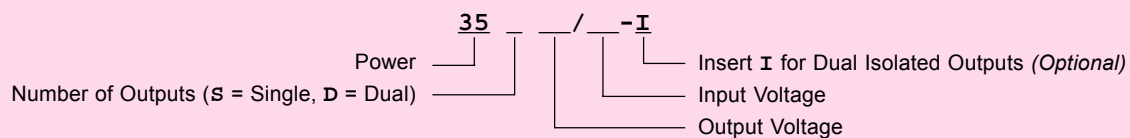

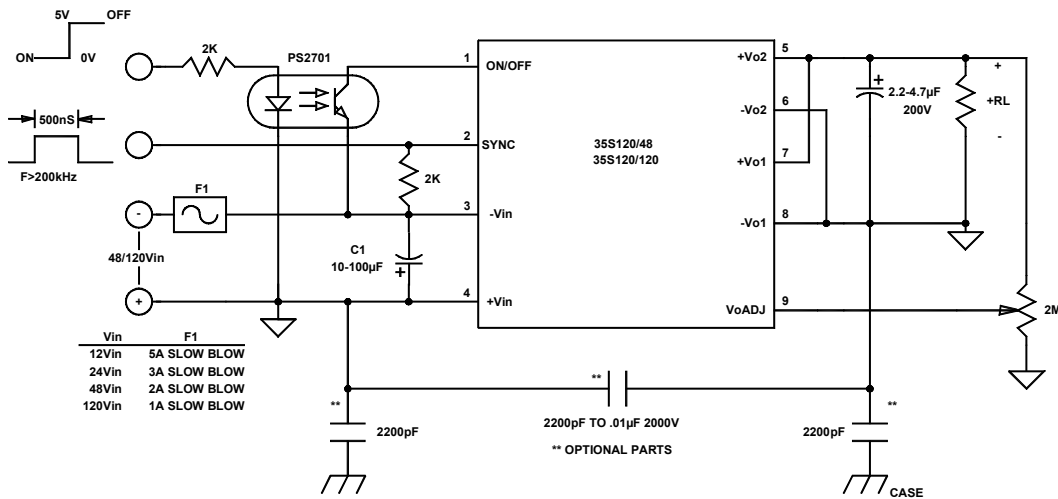

FIGURE 1. Typical connection diagram of a 35W high-voltage single output DC/DC converter

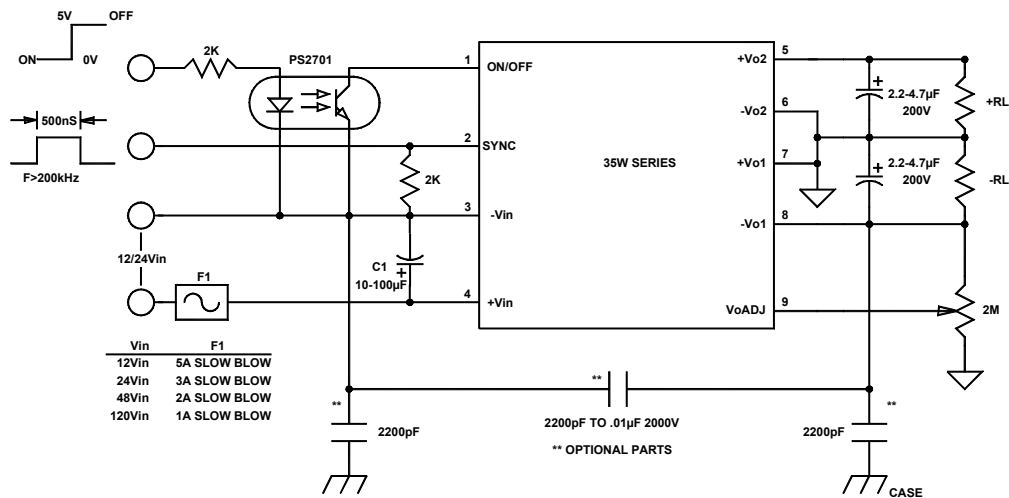

FIGURE 2. Typical connection diagram of a 35W high-voltage dual output DC/DC converter
(NOTE: Pins 6 and 7 are connected internally)

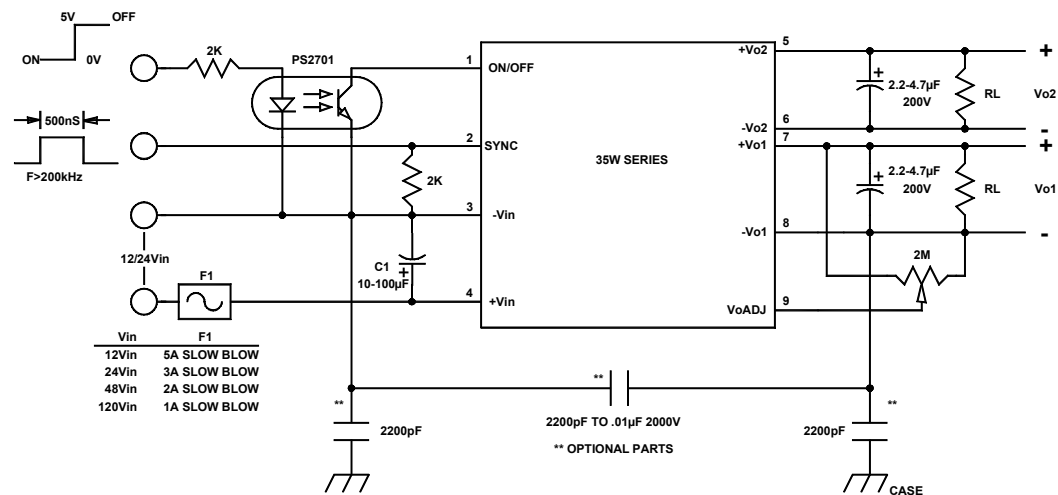
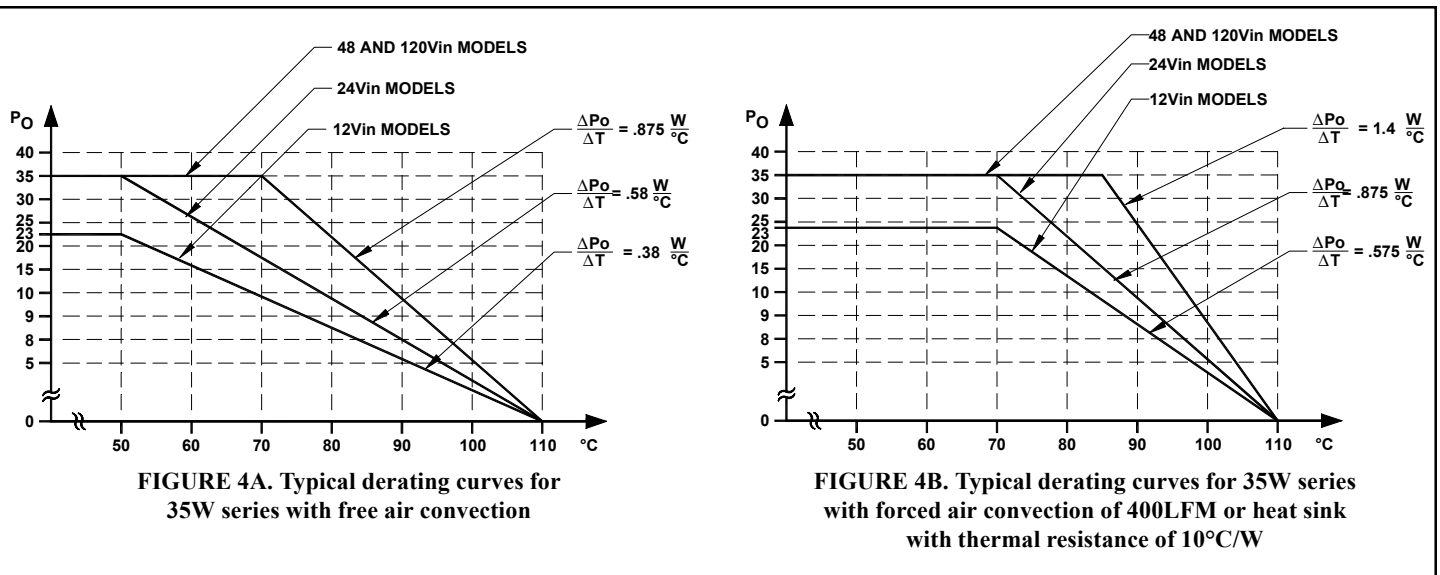

FIGURE 3. Typical connection diagram of a 35W high-voltage dual isolated output DC/DC converter



EXTERNAL TRIMMING OF OUTPUT VOLTAGES (SINGLE AND DUAL ONLY)

To trim the output voltage DOWN, connect a 5% ¼W 1.5MΩ resistor (DO NOT GO BELOW 1MΩ) between the +V_{O1} (Pin 7) output and trim pin of the converter. To trim the output voltage UP, connect a 5% ¼W resistor between the -V_{O1} (Pin 8) output and trim pins of the converter. For UP/DOWN trimming capability, connect a 2MΩ potentiometer between the + and - output pins, with the wiper arm connected to the trim pin.

The trim resistors/potentiometer can be connected at the con-

verter output pins or the load. However, if connected at the load, the resistance of the runs becomes part of the feedback network which improves load regulation. If the load is some distance from the converter, the use of #20 gauge wire is recommended to avoid excessive voltage drop due to the resistance of the circuit paths. See our application notes:

- DC-001: Testing Transient Response in DC/DC Converters
- DC-004: Thermal Consideration for DC/DC Converters

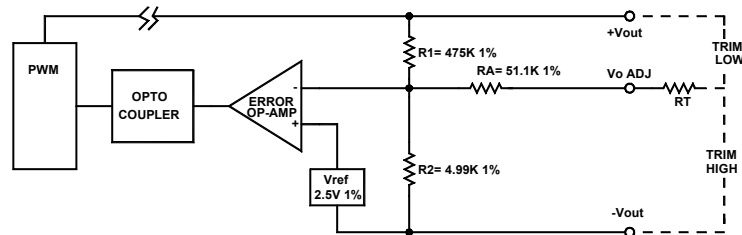

FIGURE 5. Output control circuit of 35W dual output DC/DC converter (For single output, R1 = 237K 1%)

To trim V_O higher to V_O' , where V_O is the actual measured value:

$$RT = \frac{R1 \cdot V_{REF}}{V_O' - V_O} \quad \text{For the above given values: } RT = \frac{1187500}{V_O' - V_O} - 51.5k$$

To trim V_O lower to V_O'', where V_O is the actual measured value:

$$RT = \left[\left(\frac{R_1 \cdot 2 \cdot V_{REF}}{R_2 \cdot (V_O - V_O'')} - R1 \right) - 51.5k \right]$$

EXAMPLE

To trim V_O from 240V (Pin 8 connected to GND and Pin 5 = +V_O) to 250V or ±125V with respect to Pins 6 and 7:

$$V_O = 240V, V_O' = 250V \text{ or } \pm 125V$$

$$RT = \frac{1187500}{250 - 240} - 51.1k = 67650\Omega \text{ or approx. } 68k\Omega \text{ (a standard resistor value)}$$

EXTERNAL SYNCHRONIZATION

A TTL signal applied at the SYNC pin of the converter will synchronize the switching frequency of the converter to that of the TTL input signal. The external (TTL) frequency must be equal or higher than the converter's frequency. At the positive-going edge of the applied pulse, the internal power-switching transistor turns off and the PWM discharges its timing capacitor. At the negative-going edge, the PWM resumes normal operation. The minimum positive pulse width of the TTL signal must be 300nS minimum

and its frequency between 150kHz and 180kHz. NOTE: Higher frequencies will reduce the efficiency of the converter and wide TTL pulses will force the PWM to follow the external TTL width modulation, which may effect regulation. A high TTL signal at the SYNC pin of the converter will turn the converter off. An internal pull-down resistor will keep this pin low when it is not used. A pulse differentiator (see Figure 7) can be used to shape a square wave sync signal as shown in Figure 6.

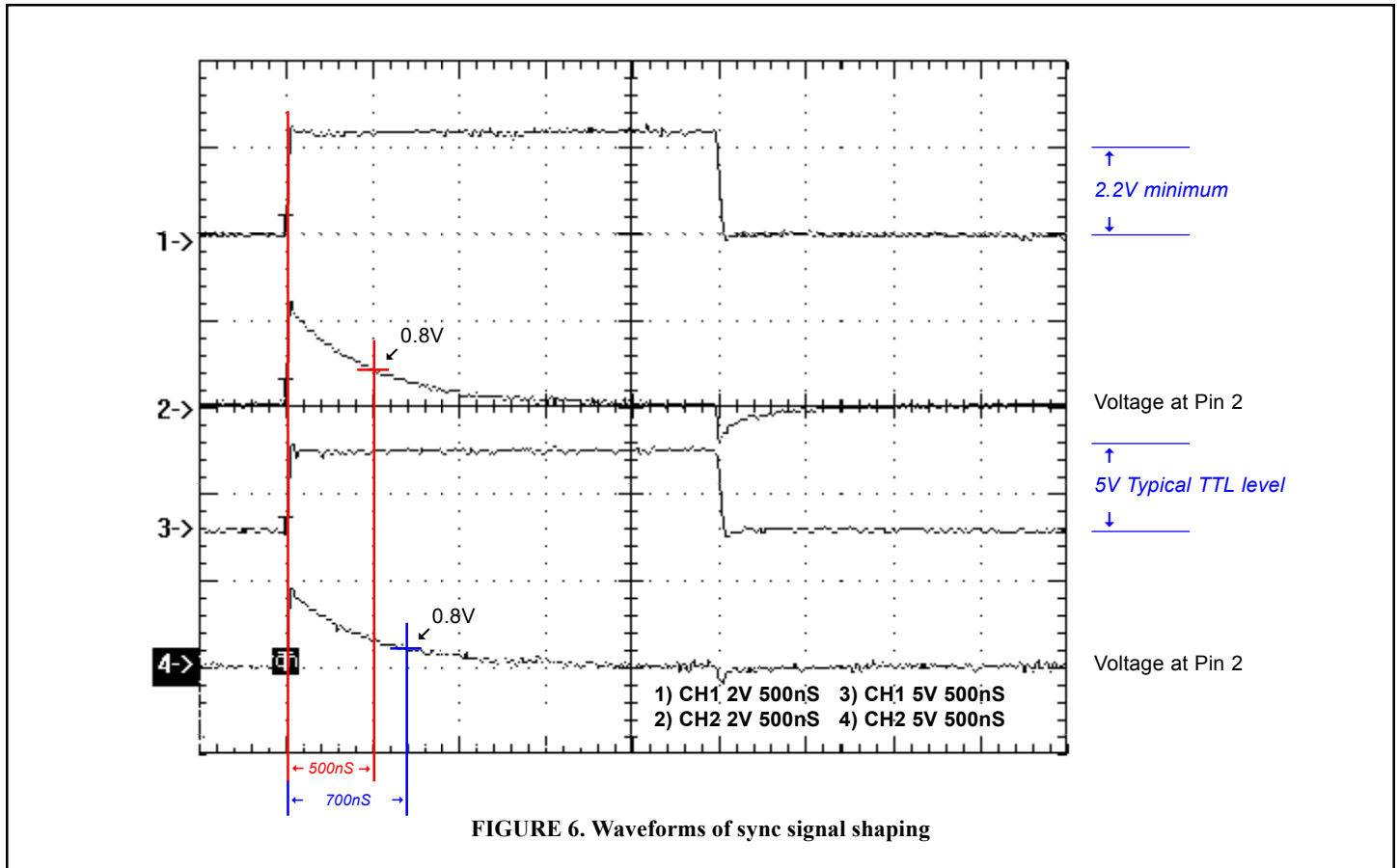

SYNC SIGNAL SHAPING

As described in External Synchronization, the PWM of the 35W converter requires a TTL signal of 0.8 to 2Vdc minimum amplitude and minimum duration of 300nS. When such a signal is not available (through one shot multivibrator or other pulse-shaping circuits) a C-R differentiator, such as the one in Figure 7, can be used to shape a square wave TTL signal. As is shown by the

oscilloscope in Figure 6, the positive edge of the sync pulse must be 2V minimum and the decaying exponential must reach the low 0.8Vdc in 300nS minimum from the positive edge. The parallel diode with the resistor is a small signal switching diode or a Schottky signal diode with 0.3 to 0.5V forward drop, it is used to clamp the voltage at pin 2@-0.5Vdc.

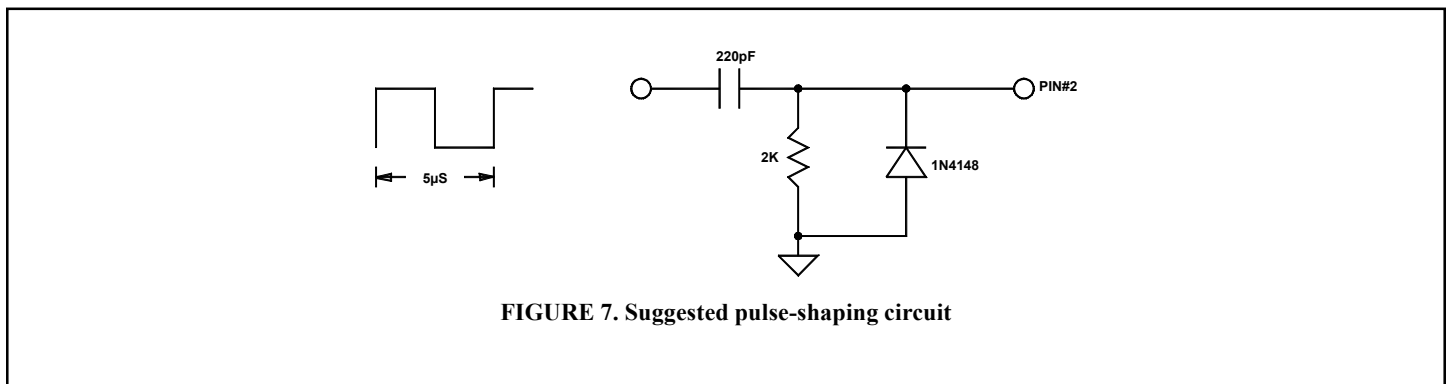

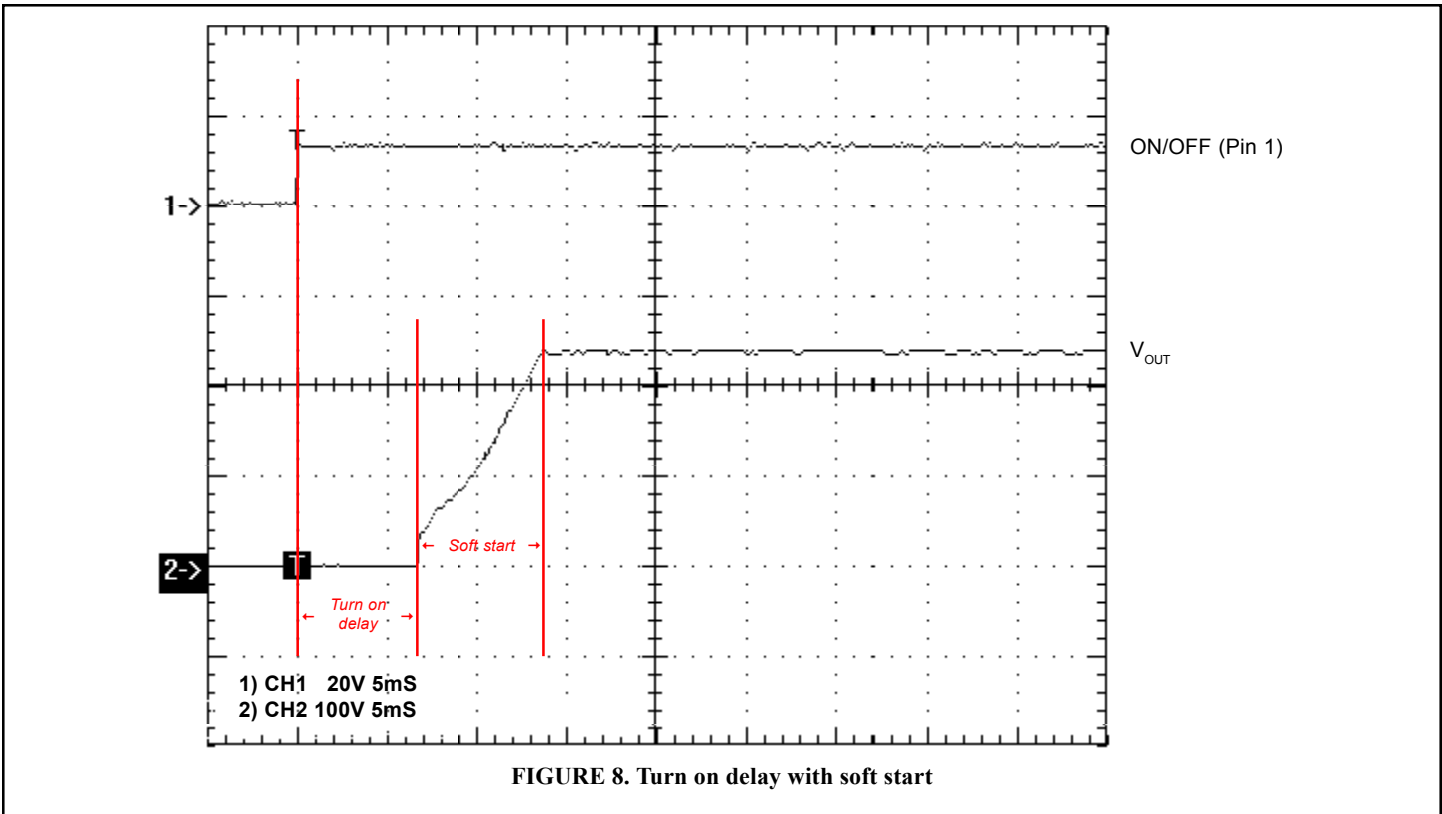

SHORT CIRCUIT PROTECTION

The converter has a dual short circuit protection feature. At the input side of the converter, two short circuit current comparators are used to monitor the input current of the converter. They are biased at different voltage levels; the lower threshold (LTH) comparator provides the power limiting function of the converter. Under normal operating conditions, the LTH comparator limits the output power of the converter when the maximum output power is exceeded.

When a hard short is applied across the output of the converter and the input current exceeds the set threshold of the second comparator, the converter goes into shutdown mode, the overcurrent latch is set and the converter is turned off. The converter will turn on again when its input voltage is recycled (OFF-ON) or if the ON/OFF pin is used to turn the converter on and off. The time required for the ON/OFF pin to be held low is between 100ms and 800ms.

