



# Low-Noise 10W DC/DC CONVERTER

Low Noise, High Efficiency, 2:1 Wide Input Range  
US Patent 5,777,519

## Key Features

- Wide input voltage range (2:1)  
(3:1 and 4:1 available upon request)
- Less than 5mV output noise
- Efficiency up to 86%
- Six-sided shielding
- Soft start
- Single/Dual output
- Short circuit protection
- Adjustable output
- 1mA off state current
- 250mV dropout linear regulators
- Dual output tracking linear regulator
- 5 $\mu$ S transient response
- Industry pinouts

### Available upon request:

- Unbalanced output voltages for dual outputs
- 1.8, 2.5, 3.3V<sub>OUT</sub>

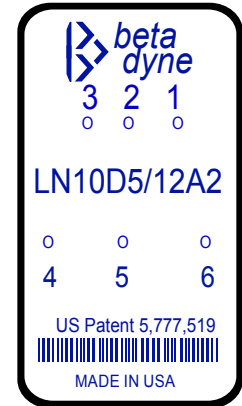

Beta Dyne is protected under various patents, including but not limited to U.S. Patent numbers: 5,777,519; 6,188,276; 6,262,901; 6,452,818; 6,473,3171.

## Applications

- High-Resolution Data Converters
- Instrumentation
- Test & Measurement
- Telecom

## Functional Description

The Low-Noise 10W series is a family of high-performance, low-noise, low-cost isolated DC/DC converters consisting of single and dual output models. The converter incorporates low switching noise techniques at its input and output sections. Low dropout linear regulators reduce the output noise to 5mV<sub>pp</sub>, while a patented control circuit maintains minimum constant dropout voltage over line, load, temperature and output adjust ranges.

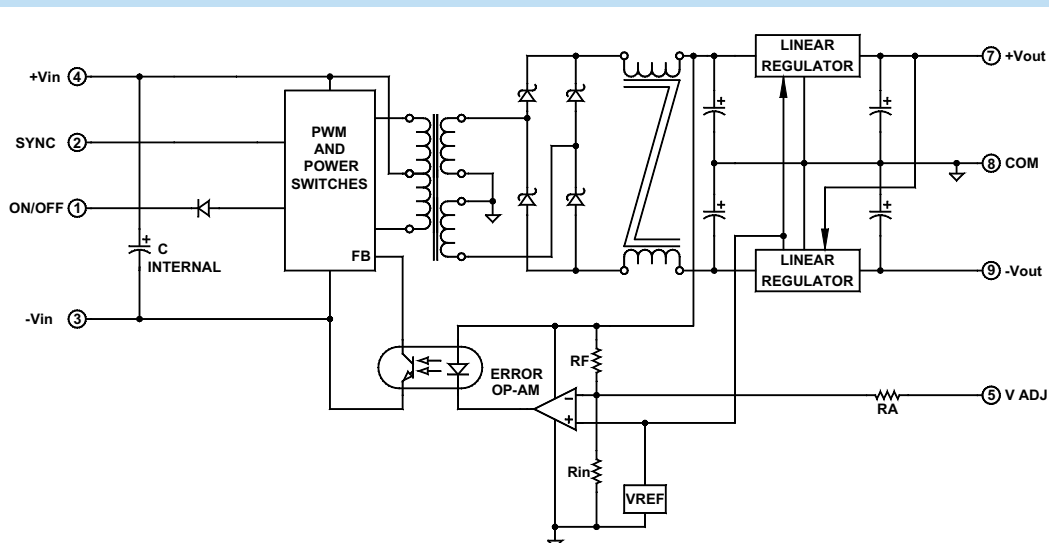

Typical Block Diagram of LN10W Dual Output Converter

## Electrical Specifications

### INPUT SPECIFICATIONS

Unless otherwise specified, all parameters are given under typical +25°C with nominal input voltage and under full output load conditions.

PARAMETER	CONDITION / NOTE	MIN	TYP	MAX	UNIT
Input Voltage Range	See Model Selection Guide				
Input Filter	C				
Reverse Polarity Input Current	External series-blocking diode			12	A
Input Surge Current (20µS Spike)				10	A
Short Circuit Current Limit			150		% I <sub>IN</sub>
Undervoltage Shutdown		4.5			Vdc
Off State Current, 5V			3		mA
Off State Current, 12, 24, 48V			750		µA
Remote ON/OFF Control					
Converter ON	Open (Open circuit voltage at Pin 1: 10V Max.)				
Converter OFF		-0.6	0	0.2	Vdc
Logic Input Reference	-Input				
Logic Compatibility	TTL Open Collector or CMOS Open Drain				

### OUTPUT SPECIFICATIONS

PARAMETER	CONDITION / NOTE	MIN	TYP	MAX	UNIT
Voltage and Current Ratings	See Model Selection Guide				
Output Voltage Accuracy, Single and Dual			±1	±1.5	%
Output Voltage Adjustment			3	±5	%
Voltage Balance, Dual <sup>1</sup>			±0.2	±0.5	%
Minimum Load <sup>1</sup>		10			% of FL
Ripple & Noise	See Figure 4, see note 8		5	10	mV <sub>pp</sub>
Line Regulation, Single and Dual	Minimum V <sub>IN</sub> to maximum V <sub>IN</sub>		0.05	0.1	%
Load Regulation, Single	NL to FL		0.05	0.1	%
Load Regulation, Dual <sup>2</sup>			±1		%
Temperature Coefficient @ FL			0.02		%/°C of V <sub>OUT</sub>
Transient Response Time (to within 0.5% of V <sub>OUT</sub> )	50% FL to FL to 50% FL, See Figure 1		5		µS
Short Circuit Protection	All outputs, by input current limiting				

### GENERAL SPECIFICATIONS

PARAMETER	CONDITION / NOTE	MIN	TYP	MAX	UNIT
Efficiency	See Model Selection Guide				
Isolation Voltage (1 min.)			1500		Vdc
Isolation Resistance			10 <sup>9</sup>		Ω
Isolation Capacitance			80		pF
Switching Frequency		300	320	333	kHz

### ENVIRONMENTAL SPECIFICATIONS

PARAMETER	CONDITION / NOTE	MIN	TYP	MAX	UNIT
Operating Temperature, Industrial (Ambient) <sup>*</sup>	See Figure 2	-40		+75	°C
Operating Temperature, Extended (X)	See Ordering Guide (Please contact factory)	-55		+85	°C
Storage Temperature Range		-55		+125	°C
Thermal Resistance			3.5	4	°C/W <sub>DISS</sub>
Maximum Operating Case Temperature				105	°C
Derating	See Figure 2				
Humidity	Up to 95% non-condensing				
Cooling	Free-air convection				
EMI/RFI	Six-sided continuous shielded metal case				
MTBF	per MIL-HNBK-217F (Ground benign, +25°C)		1×10 <sup>6</sup>		hours

\* See footnotes 3, 4, 5 and 6

**PHYSICAL CHARACTERISTICS**

PARAMETER	CONDITION / NOTE	MIN	TYP	MAX	UNIT
Dimensions (L×W×H)	2.00×1.00×0.395 in. (50.80×25.40×10.03mm)				
Weight	1.04 oz. (30g)				
Case Material	Coated metal				
Shielding Connection, 5, 12, 24V <sub>IN</sub>	-Input (Pin 3)				
Shielding Connection, 48V <sub>IN</sub>	+Input (Pin 4)				

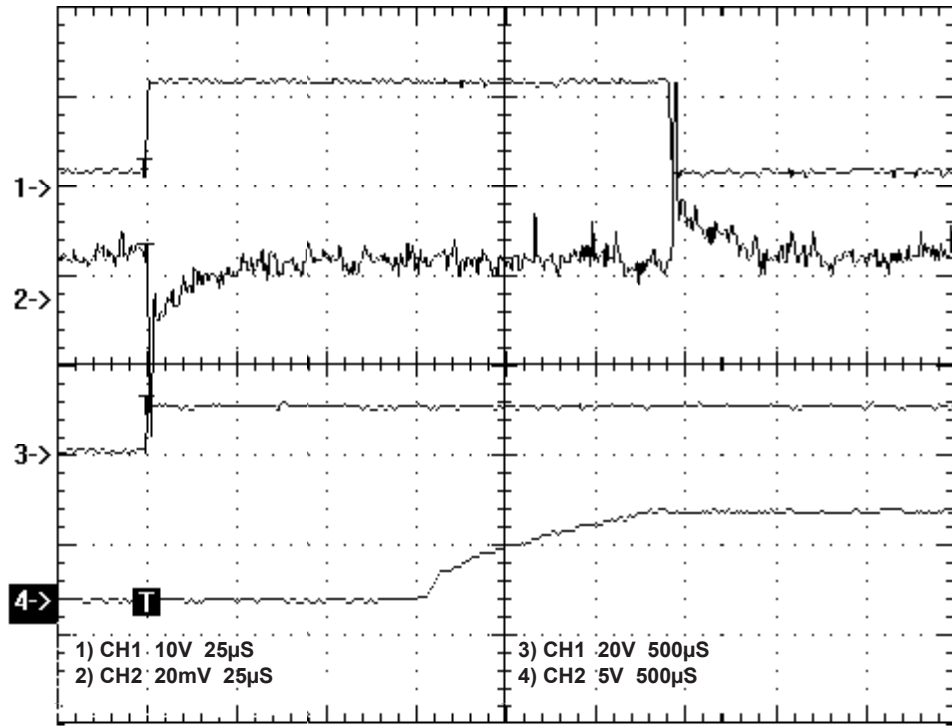

**FIGURE 1. Transient response and turn on delay with soft start**

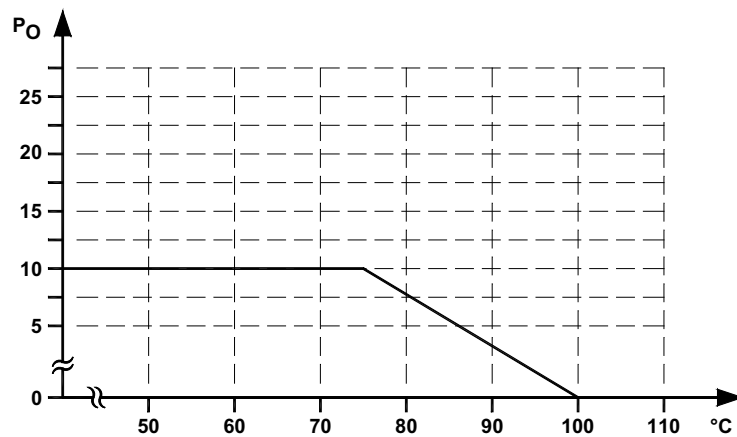

**FIGURE 2. Typical derating curve of Low-Noise 10W series**

**OUTPUT VOLTAGE ADJUSTMENT**

For both single and dual models, the output reference voltage is referenced to the output ground: Pin 6 for singles and Pin 8 for duals. To trim the output voltage high, connect a 1% resistor (0kΩ–200kΩ range) between -V<sub>OUT</sub> (Pin 6) and V<sub>OUT</sub> Adjust (Pin 9) for the singles, and COM (Pin 8) and V<sub>OUT</sub> Adjust (Pin 5) for the duals. To trim the output voltage low, connect a 1% resistor (50kΩ–500kΩ range) between +V<sub>OUT</sub> (Pin 5) and V<sub>OUT</sub> Adjust (Pin 9) for the singles,

and +V<sub>OUT</sub> (Pin 7) and V<sub>OUT</sub> Adjust (Pin 5) for the duals.

With the wiper connected to the V<sub>OUT</sub> Adjust pin, a variable resistor (potentiometer) can also be used for V<sub>OUT</sub> adjustment by connecting each end to +V<sub>OUT</sub> and -V<sub>OUT</sub> for the singles, and +V<sub>OUT</sub> and COM for the duals. A potentiometer between 50kΩ–100kΩ can be used. Avoid using a low resistance potentiometer or a high temperature coefficient such as wound wire.

## Model Selection Guide

MODEL NUMBER	INPUT				Reflected Ripple <sup>7</sup> (mA <sub>pp</sub> )	OUTPUT		
	Voltage (Vdc)		Current (mA)			Voltage (Vdc)	Current (mA)	Efficiency Full Load (%)
	Nominal	Range	No Load	Full Load				
LN10S3.3/5	5	4.75-9	40	2901	100	3.3	3000	68
LN10S5/5	5	4.75-9	70	2143	100	5	1500	70
LN10S12/5	5	4.75-9	70	2564	100	12	830	79
LN10S15/5	5	4.75-9	70	2564	100	15	670	79
LN10S5/12	12	9.5-18	30	1111	100	5	2000	75
LN10S12/12	12	9.5-18	30	1016	100	12	830	82
LN10S15/12	12	9.5-18	30	1000	100	15	670	83
LN10S2.5/24	24	18-36	30	620	100	2.5	4000	66
LN10S3.3/24	24	18-36	20	620	100	3.3	3000	66
LN10S5/24	24	18-36	20	520	100	5	2000	80
LN10S6/24	24	18-36	30	510	100	6	1660	81
LN10S12/24	24	18-36	20	496	100	12	830	84
LN10S15/24	24	18-36	20	504	100	15	670	84
LN10S3.3/48	48	36-72	10	280	100	3.3	3000	74
LN10S5/48	48	36-72	10	260	100	5	2000	80
LN10S12/48	48	36-72	10	248	100	12	830	84
LN10S15/48	48	36-72	10	245	100	15	670	85
LN10D5/5	5	4.75-9	70	2222	100	±5	±800	72
LN10D12/5	5	4.75-9	70	2632	100	±12	±417	76
LN10D15/5	5	4.75-9	70	2597	100	±15	±333	77
LN10D5/12	12	9-18	30	1126	100	±5	±1000	74
LN10D6/12	12	9-18	30	860	100	±6	±650	75
LN10D12/12	12	9-18	30	1030	100	±12	±417	81
LN10D15/12	12	9-18	30	1030	100	±15	±333	81
LN10D5/24	24	18-36	20	514	100	±5	±1000	81
LN10D12/24	24	18-36	20	490	100	±12	±417	85
LN10D15/24	24	18-36	20	490	100	±15	±333	85
LN10D5/48	48	36-72	10	257	100	±5	±1000	81
LN10D12/48	48	36-72	10	245	100	±12	±417	85
LN10D15/48	48	36-72	10	242	100	±15	±333	86
<i>Contact factory for custom input and output voltage combinations</i>								

- <sup>1</sup> In applications where the  $-V_{OUT}$  is loaded more than  $+V_{OUT}$ , a minimum load is required between  $+V_{OUT}$  and GND. If the load is connected between  $+V_{OUT}$  and  $-V_{OUT}$ , no minimum load is required.
- <sup>2</sup> For dual converters if only the  $-V_{OUT}$  is loaded. A 10% FL must be connected from  $+V_{OUT}$  to Ground.
- <sup>3</sup> Contact factory for  $-55^{\circ}$  to  $+85^{\circ}\text{C}$  operating temperature range.
- <sup>4</sup> The maximum input current at any given input range measured at minimum input voltage is given as  $1.6 \cdot I_{NOMINAL}$ . Nominal input current is the typical value measured at the input of the converter under full-load room temperature and nominal input voltage (5, 12, 24 and  $48V_{IN}$ ).
- <sup>5</sup> Adequate insulation is to be provided to the converters at the end usage as per applicable requirements.
- <sup>6</sup> Temperature rise on the case of the converters is to be considered during the end usage as per applicable requirements.
- <sup>7</sup> Measured without external filter. When the recommended filter is used, a reduction by a factor of 5 or more is achieved. See Figure 5.
- <sup>8</sup> For A1 and A2 models output ripple is 15mV peak to peak max. or less .

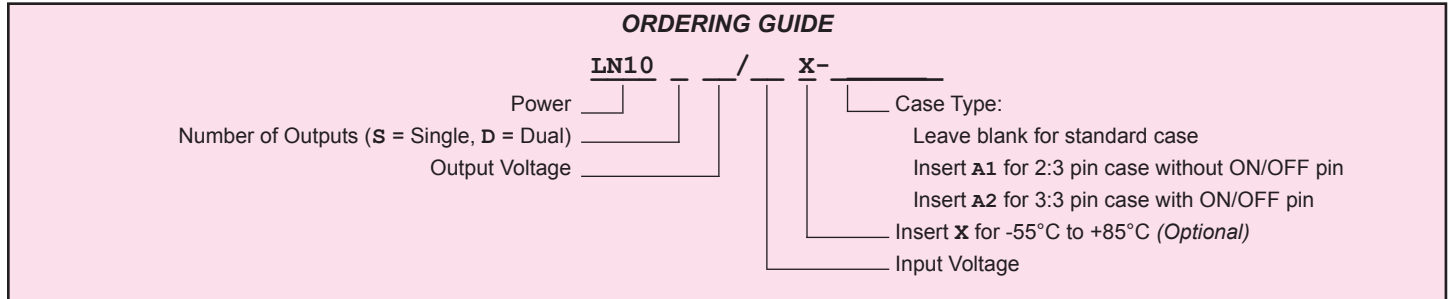

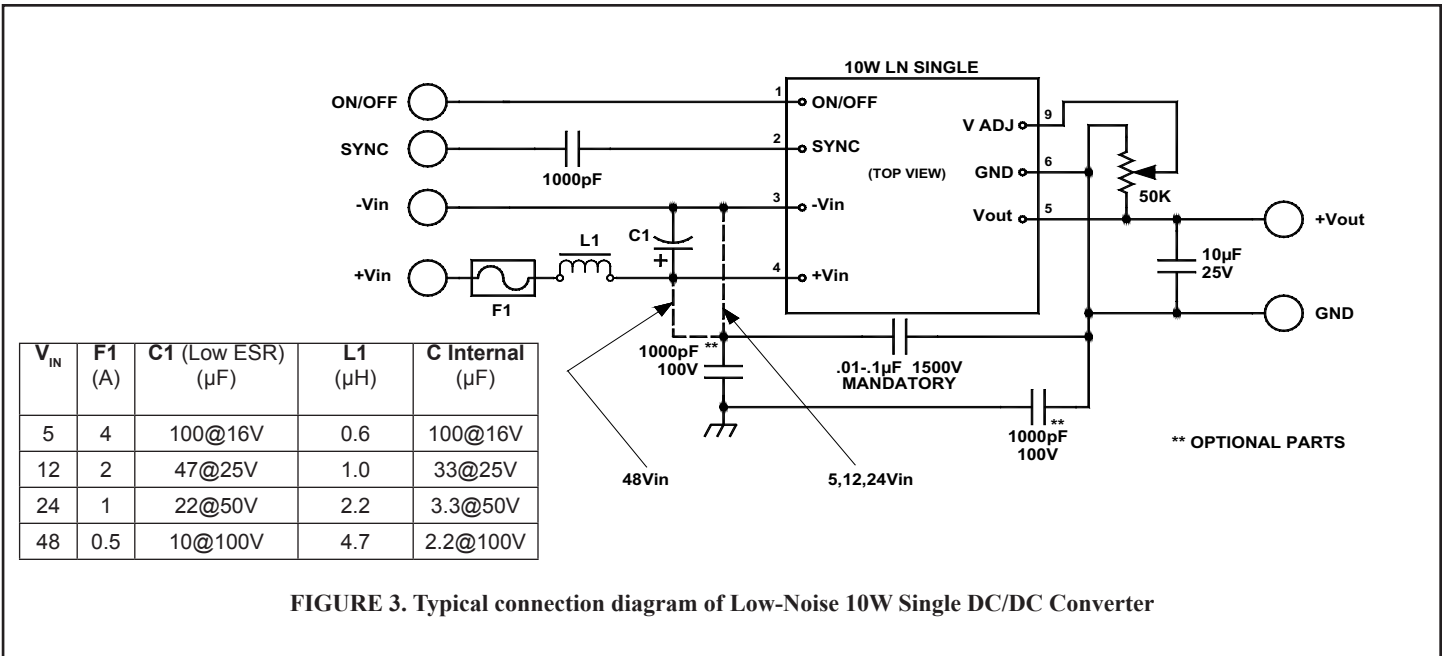

FIGURE 3. Typical connection diagram of Low-Noise 10W Single DC/DC Converter

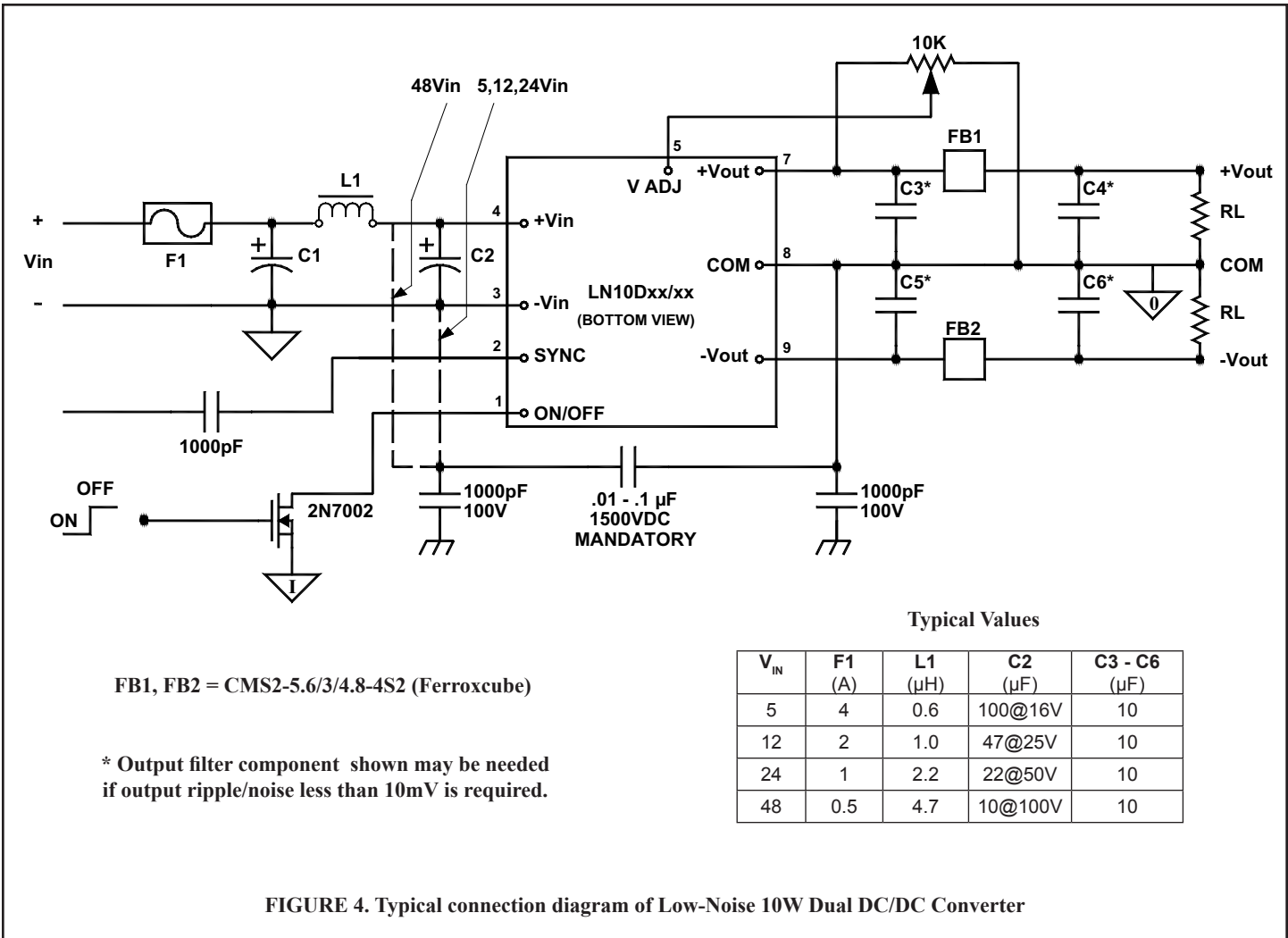
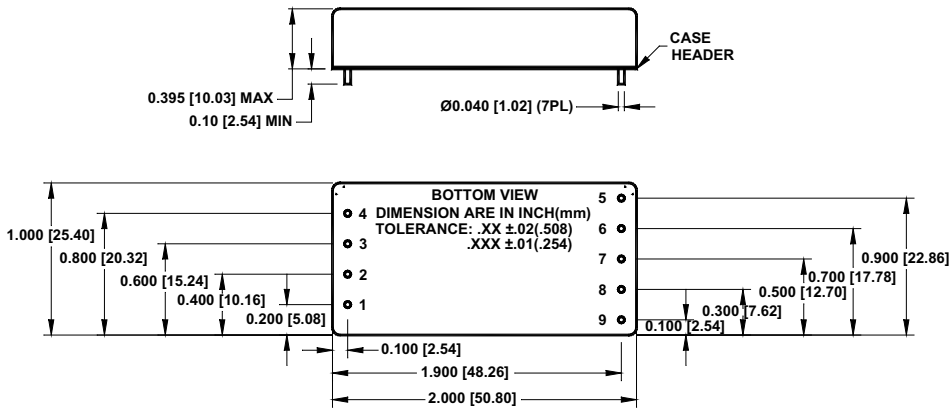

FIGURE 4. Typical connection diagram of Low-Noise 10W Dual DC/DC Converter

**MECHANICAL SPECIFICATIONS  
STANDARD CASE**



**STANDARD CASE**

Pin	Function	
	SINGLE	DUAL
1	ON/OFF	ON/OFF
2	SYNC	SYNC
3	-V <sub>IN</sub>	-V <sub>IN</sub>
4	+V <sub>IN</sub>	+V <sub>IN</sub>
5	+V <sub>OUT</sub>	V <sub>OUT</sub> ADJ
6	GND	No Pin
7	No Pin	+V <sub>OUT</sub>
8	No Pin	COM
9	V <sub>OUT</sub> ADJ	-V <sub>OUT</sub>

**A1/A2 CASE**

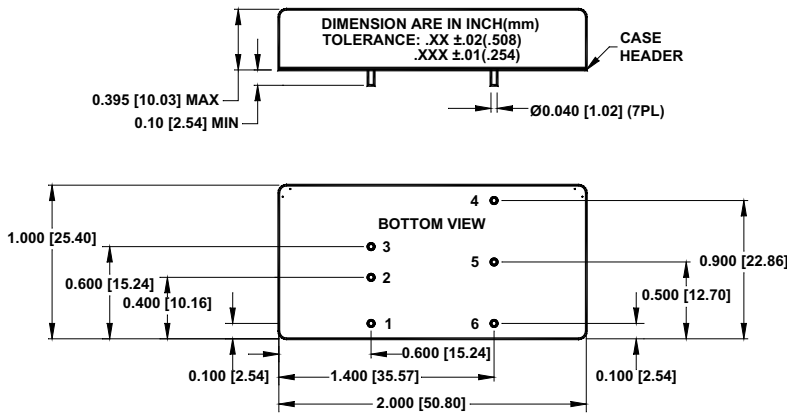

**A1/A2 CASE**

Pin	Function	
	SINGLE	DUAL
1	ON/OFF	ON/OFF
2	-V <sub>IN</sub>	-V <sub>IN</sub>
3	+V <sub>IN</sub>	+V <sub>IN</sub>
4	+V <sub>OUT</sub>	+V <sub>OUT</sub>
5	V <sub>OUT</sub> ADJ	GND (COM)
6	GND	-V <sub>OUT</sub>

**EXTERNAL SYNCHRONIZATION**

This series of converters can be synchronized to an external system clock of 320kHz -2% to 10%. The external clock is AC-coupled to the input SYNC terminal (Pin 2) through a coupling capacitor

from 220pF to 1000pF. The required amplitude is 3.3V to 5V and its duty cycle is 50% ±20%. Please refer to *Application Note DC-005: Synchronization* for more information.

0.6

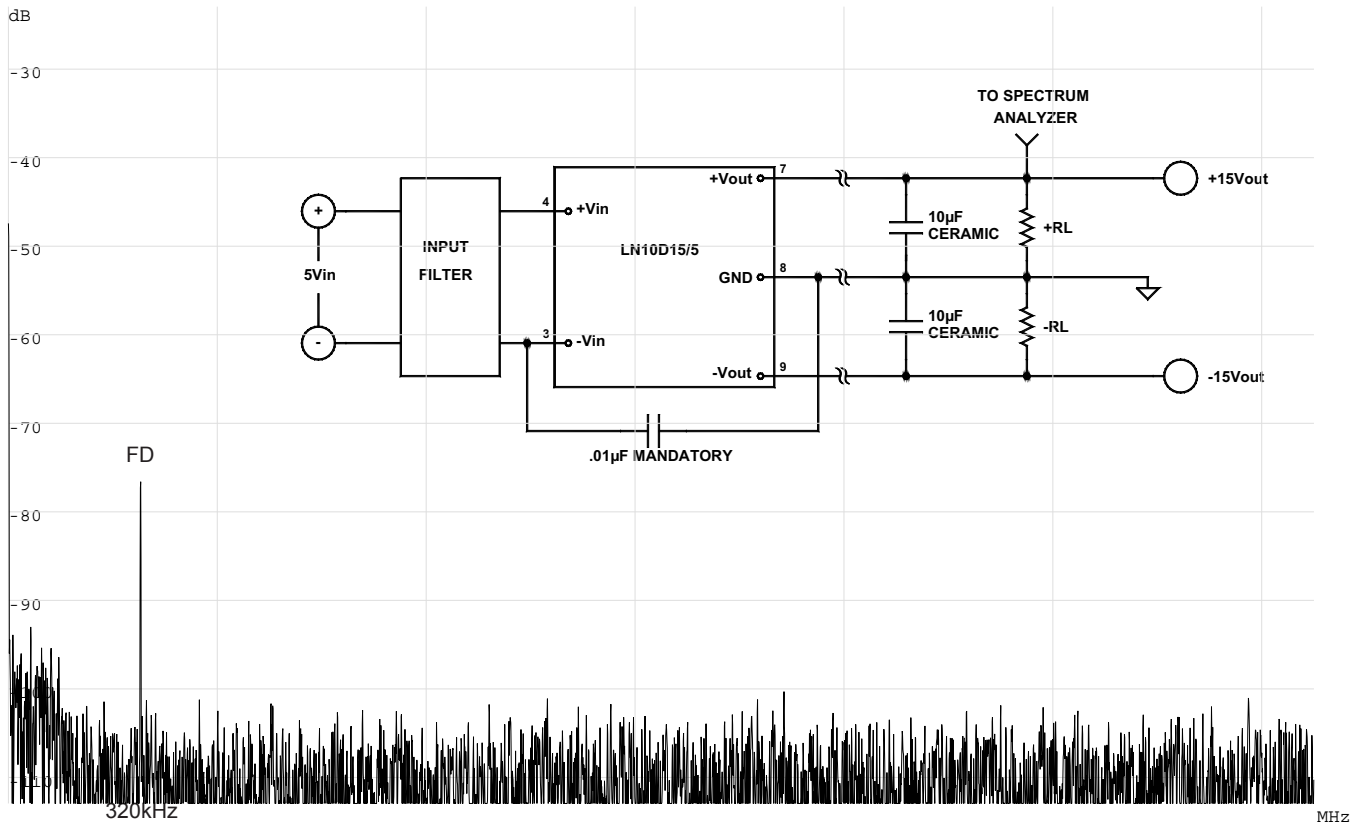

FIGURE 5. Setup and reading for output voltage noise spectrum

0.6

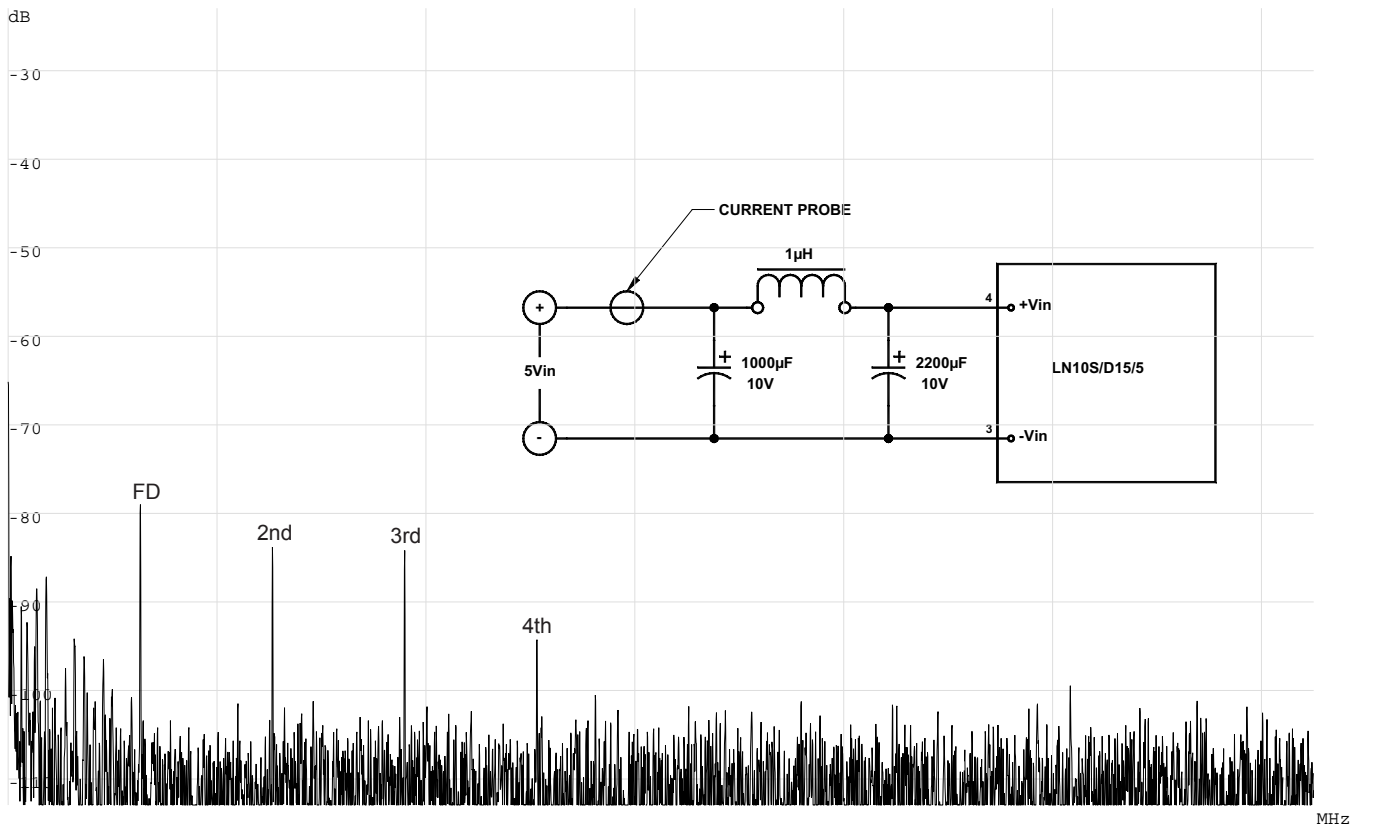

FIGURE 6. Setup and reading for reflected ripple current