



ARG3002

40W ADJUSTABLE DC/DC CONVERTER

$0V_{OUT}$ to $120V_{OUT}@333mA$

US Patent 6,188,276 B1

Key Features

- 84% efficiency
- External amplitude selection 0–120Vdc
- Onboard 5Vdc reference
- Remote ON/OFF control
- 300 μ A off state current
- Isolated output
- Over/under input voltage protection
- Short circuit protection
- Six-sided shielding

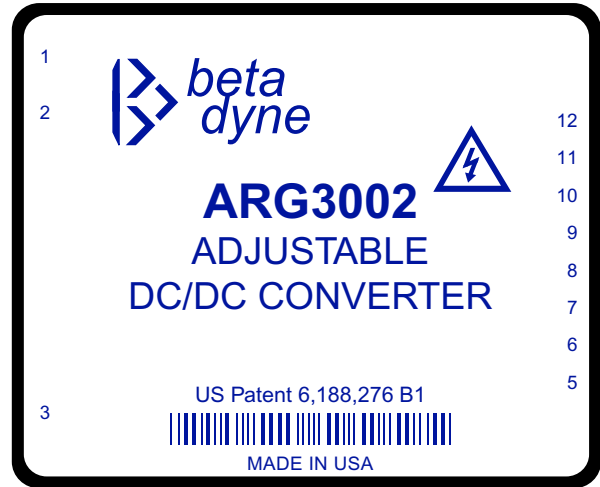

Functional Description

The ARG3002 is an isolated, adjustable 40W DC/DC converter with an input voltage range of 40Vdc to 60Vdc and an adjustable output from 0Vdc to 120Vdc. The converter offers a maximum output power of 40W (120V@333mA). An input voltage from 0V to 5V at its non-inverting input (Pin 9 with Pin 8 open) will generate 0Vdc to 120Vdc at its output. **The case and header are connected together; no other connection exists between the case and either input or output pins.**

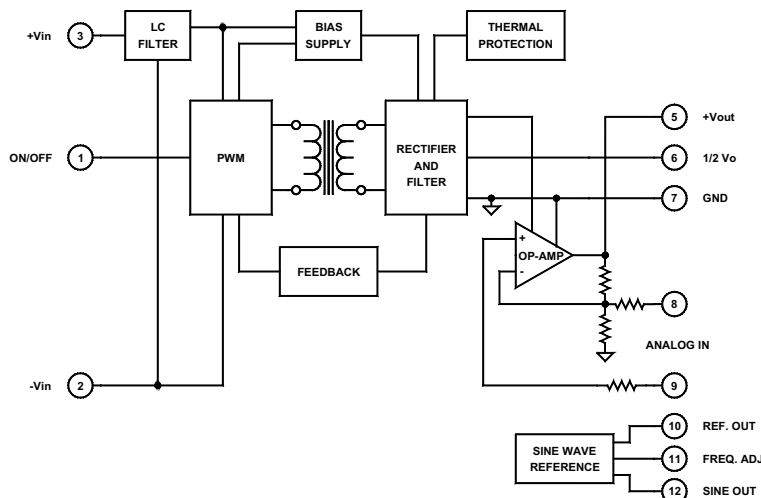

Typical Block Diagram

Electrical Specifications

INPUT SPECIFICATIONS

Unless otherwise specified, all parameters are given under typical +25°C with nominal input voltage and under full output load conditions.

PARAMETER	CONDITION / NOTE	MIN	TYP	MAX	UNIT
Input Voltage Range		40	48	60	Vdc
Input Current, No Load			20		mA
Input Current, Full Load			991		mA
Short Circuit Current	Input Current Limit	$I_{IN FL}$			
Input Reflected Ripple	$C_{IN} = 100\mu F$		250		mA_{PP}
Switching Frequency	PWM frequencies		250		kHz
Start Up Threshold		35			Vdc
Under Voltage Shutdown			10		Vdc
Input Filter Type	π (Pi)				
Off State Current			300		μA
Remote ON/OFF Control					
Converter ON	Open (Open circuit voltage at Pin 1: 10V Max.)				
Converter OFF		-0.6	0	0.2	Vdc
Logic Input Reference	-Input (Pin 2)				
Logic Compatibility	TTL Open Collector or CMOS Open Drain				

OUTPUT SPECIFICATIONS

PARAMETER	CONDITION / NOTE	MIN	TYP	MAX	UNIT
Output Voltage	Pin 7 = GND, Pin 5 = V_{OUT}	0		120	Vdc
Output Current			330		mA
Short Circuit Protection	Input current limit				
Load Step Response within 1% of V_{OUT}	50% FL to FL to 50% FL		500		μS
Turn On Delay			8		mS
Output Ripple & Noise	20MHz bandwidth (See App. Note RG-001)		1		% of V_{OUT}
Load Regulation	Minimum to Full Load		1		% of V_O
Line Regulation	Minimum to maximum input voltage			± 0.5	%
Temperature Coefficient	Nominal line		± 0.01	± 0.02	%/°C
Efficiency	Full Load ($V_{IN} = 48V$, $V_{OUT} = 120V$)		84		%
Transient Response	50% FL to FL to 50% FL to within 1% of V_{OUT} (See App. Note RG-003)		75		μS
Isolation			1500		Vdc

ENVIRONMENTAL SPECIFICATIONS

PARAMETER	CONDITION / NOTE	MIN	TYP	MAX	UNIT
Operating Temperature Range		-40		71	°C
Thermal Resistance				1.2	°C/W
MTBF	per MIL-HDBK-217F (Ground benign, +25°C)		300,000		hours

PHYSICAL CHARACTERISTICS

PARAMETER	CONDITION / NOTE	MIN	TYP	MAX	UNIT
Dimensions (L×W×H)	3.00×2.54×0.77 in. (76.20×64.52×19.43mm)				
Weight	7.48 oz. (212g)				
Case Material	Coated metal				
Case Connection	Case & header are floating and have no connection to either input or output pins				

MECHANICAL SPECIFICATIONS

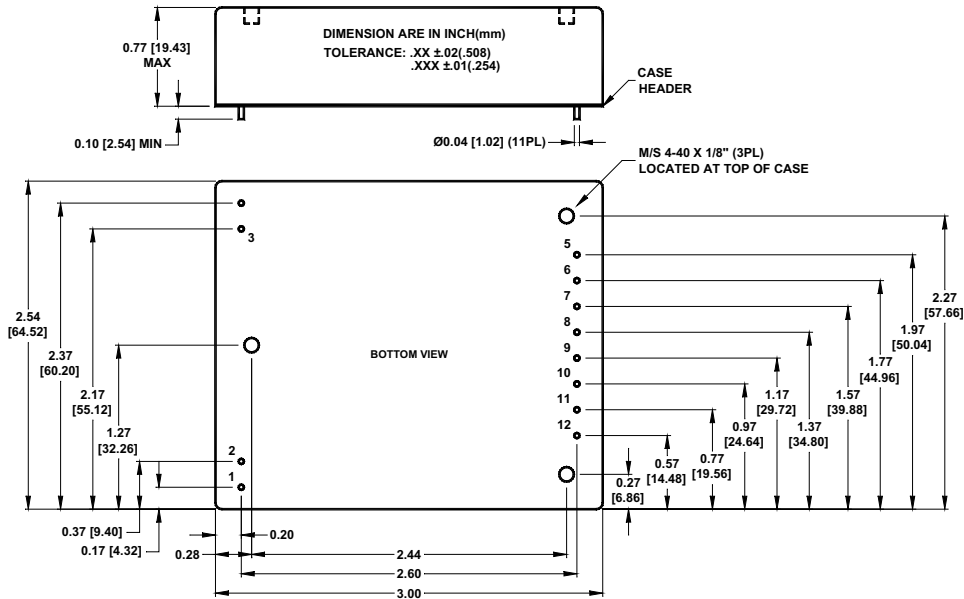

1	ON/OFF
2	-V _{IN}
3	+V _{IN}
4	No Pin
5	+V _{OUT}
6	GND
7	-V _{OUT}
8	INV INPUT
9	NON-INV INPUT
10	REF. OUT
11	FREQ. ADJ
12	SINE OUT

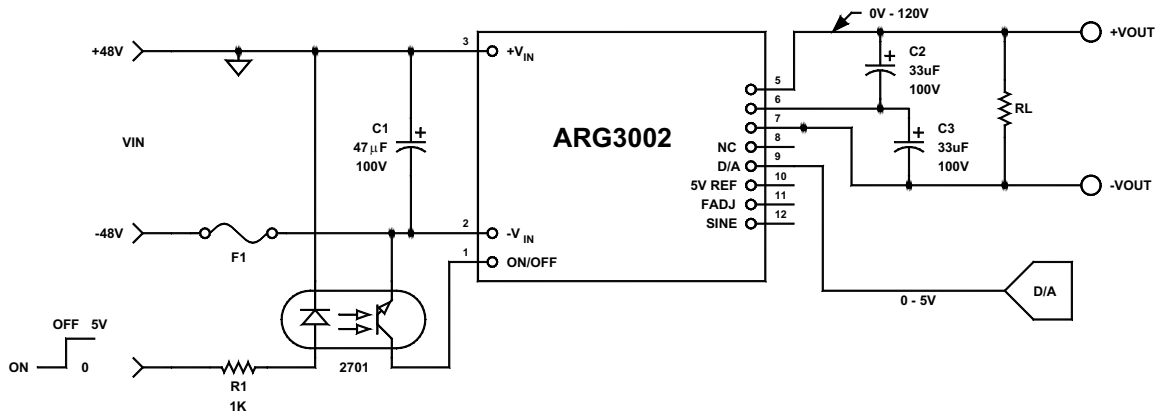

FIGURE 1. Typical connection diagram

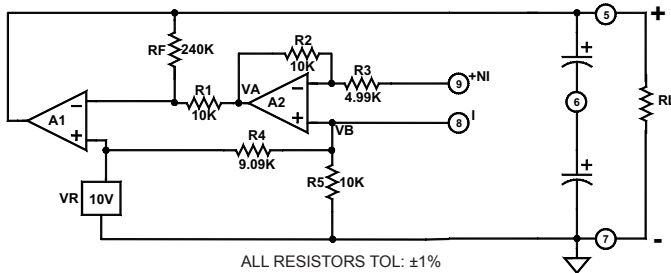

FIGURE 2. Output stage

- $V_o = V_R \left(1 + \frac{R_F}{R_1}\right) - \frac{R_F}{R_1} V_A$
- $V_A \Big|_{\text{Pin 8 open}} = V_B \left(1 + \frac{R_2}{R_3}\right) - \frac{R_2}{R_3} V_{NI}$
- $V_o = 250 - 24V_A$
- $V_A \Big|_{\text{Pin 8 open}} = 5.2083(2) - V_{NI}$
- $V_A \Big|_{\text{Pin 8 open}} = 10.4167 - V_{NI}$
- $V_o = 250 - 24(10.4167 - V_{NI})$
- $V_o = 250 - 250 + 24V_{NI}$
- $V_o = 24V_{NI}$

V _{IN}	F1
12V	8A
24V	4A
48V	2A