



BD10018

10W SINGLE DC/DC CONVERTER

2.5:1 Input Voltage Range

Key Features

- Input-to-output isolation
- Soft start
- Input LC filter
- Short circuit and thermal protection
- Wide 2.5:1 input voltage range (100–250Vdc)
- EMI six-sided shielding



Functional Description

The BD10018 is a 10W single DC/DC converter in a 2×1×0.395-inch package that provides 5V_{OUT}@2A with an operating temperature range from -25°C to +60°C. The converter requires a minimum load of 10% FL.

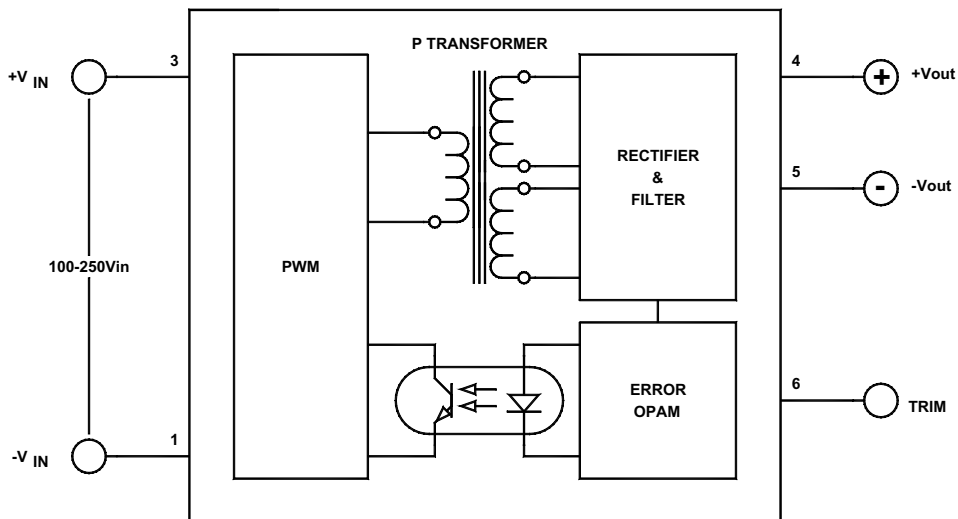

Typical Block Diagram

Electrical Specifications

INPUT SPECIFICATIONS

Unless otherwise specified, all parameters are given under typical +25°C with nominal input voltage and under full output load conditions.

PARAMETER	CONDITION / NOTE	MIN	TYP	MAX	UNIT
Input Voltage Range		100	175	250	Vdc
Input Voltage Slew Rate				10	V/μS
No Load Input Current	@175Vdc		2.5		mA
Full Load Input Current	@175Vdc		70		mA
Input Filter	C				
Reflected Ripple Current	Measured with 10μF input capacitor		100		mA _{pp}
Reverse Voltage Protection	Parallel Diode		5		A
On/Off	Reference to -V _{IN}				
Voltage	Open		10		Vdc
Turn On Delay	Including soft start, See Figure 2		25	35	mS
Startup Input Voltage		11	16		Vdc

OUTPUT SPECIFICATIONS

PARAMETER	CONDITION / NOTE	MIN	TYP	MAX	UNIT
Output Voltage			5.00		Vdc
Output Voltage Accuracy			1	2	%
Output Current			2		A
Ripple & Noise (20MHz BW)			1	2	% of V _{OUTTP}
Line Regulation	Outputs fully loaded		1		%
Load Regulation	10% FL to FL		1		%
OVP	5.6V Zener across V		5.6		Vdc
Temperature Coefficient @ FL			±0.02		%/°C
Short Circuit Protection	Continuous, Current Limit				
Short Circuit Restart	Automatic				
Transient Response (to within 1% of V)	50% FL to 100% FL to 50% FL, See Figure 3		250		μS

GENERAL SPECIFICATIONS

PARAMETER	CONDITION / NOTE	MIN	TYP	MAX	UNIT
Efficiency			80		%
Isolation Voltage (1 min.)		500	1000		Vdc
Isolation Resistance			10 ⁹		Ω
Isolation Capacitance			300		pF
Switching Frequency		115	130	140	kHz

ENVIRONMENTAL SPECIFICATIONS

PARAMETER	CONDITION / NOTE	MIN	TYP	MAX	UNIT
Operating Temperature Range (Ambient)		-25		+60	°C
Storage Temperature Range		-60		+125	°C
Derating	See Figure 4				
Thermal Protection, Turn Off ¹	Junction Temperature		145		°C
Thermal Hysteresis			30		°C
Humidity	Up to 95% non-condensing				
Cooling	Free-air convection				
MTBF	per MIL-HNBK-217F (Ground benign, +25°C)		1.2×10 ⁶		hours

PHYSICAL CHARACTERISTICS

PARAMETER	CONDITION / NOTE	MIN	TYP	MAX	UNIT
Dimensions (L×W×H)	2.00×1.00×0.395 in. (50.80×25.40×10.03mm)				
Weight	1.04 oz. (30g)				
Case Material	Coated metal				
Shielding	Six-sided continuous				
Case Connection	IN				

¹ Input power may have to be recycled after thermal turn off.

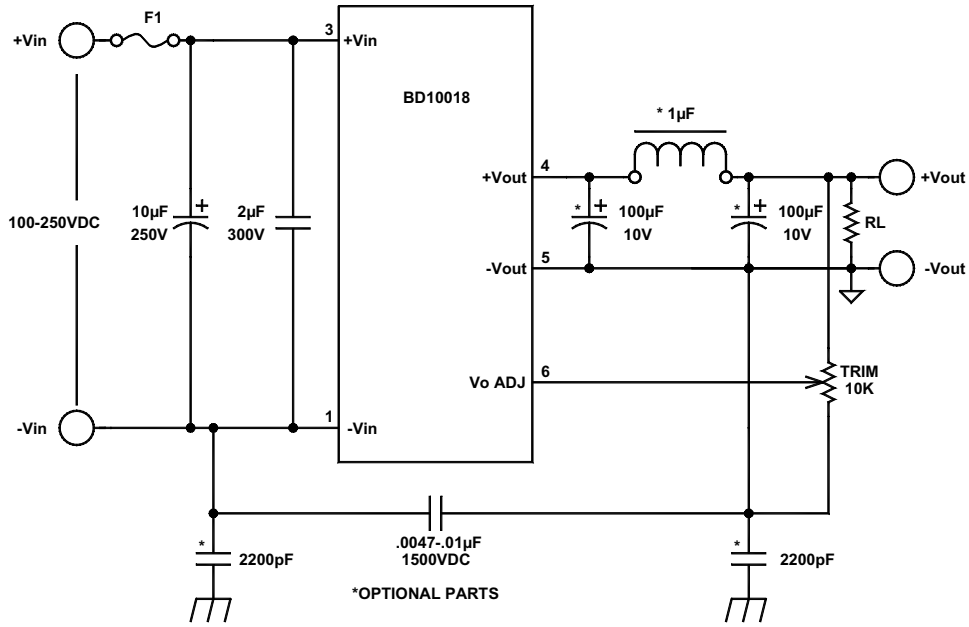

FIGURE 1. Connection diagram

MECHANICAL SPECIFICATIONS

DIMENSIONS ARE IN INCH(mm)

TOLERANCES: .XX ±.01(.254)

.XXX ±.005(.127)

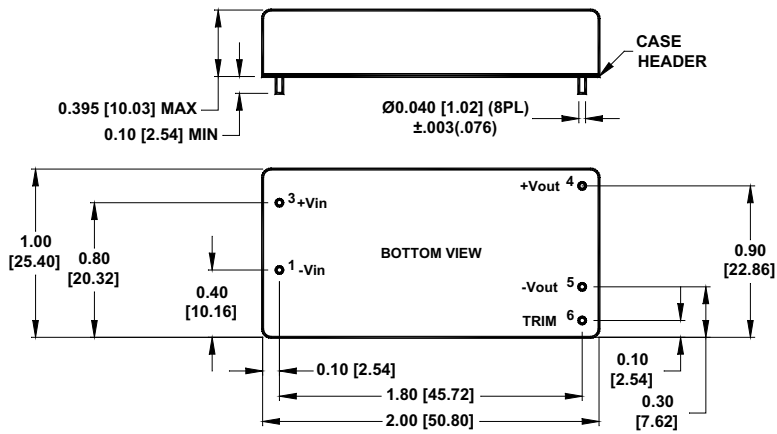

Pin	Function
1	-V _{IN}
2	No Pin
3	+V _{IN}
4	+V _{OUT}
5	-V _{OUT}
6	TRIM

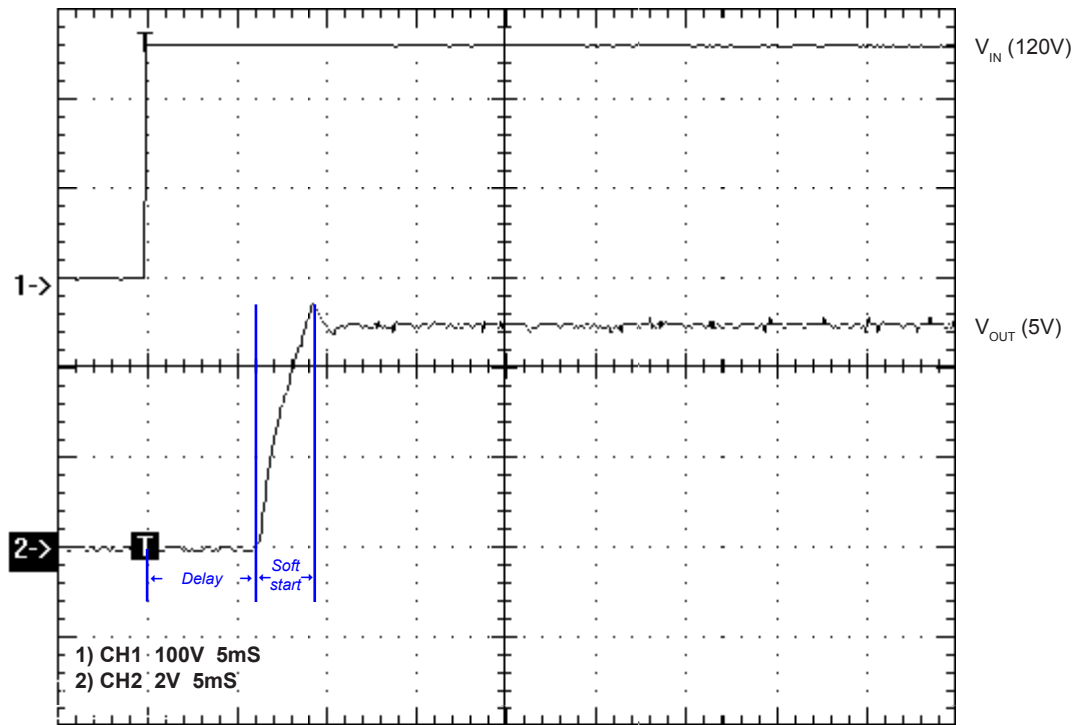

FIGURE 2. Turn on delay with soft start

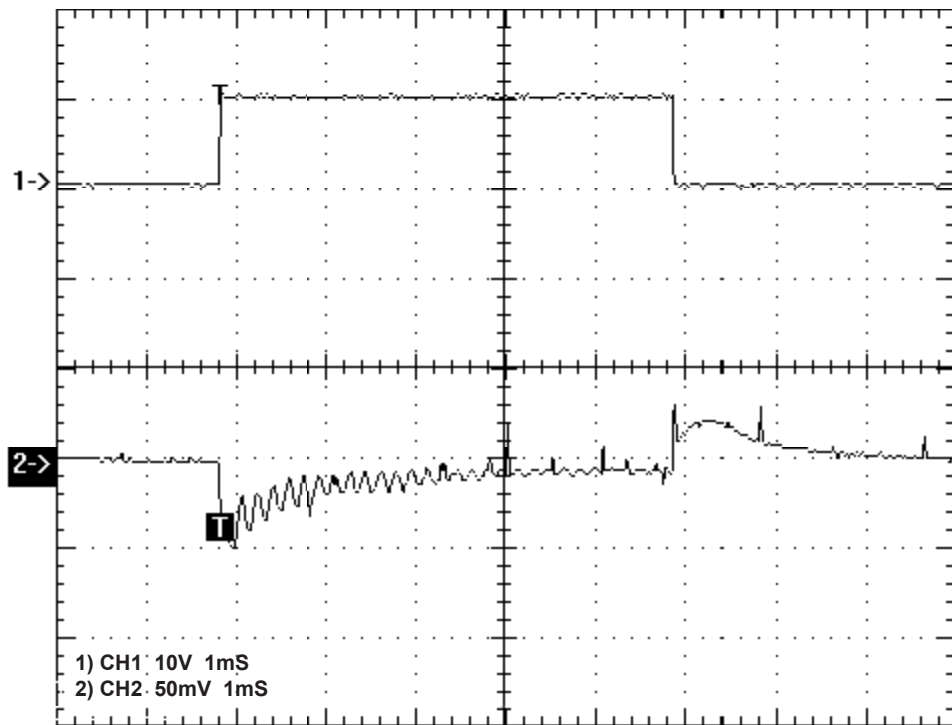

FIGURE 3. Transient response

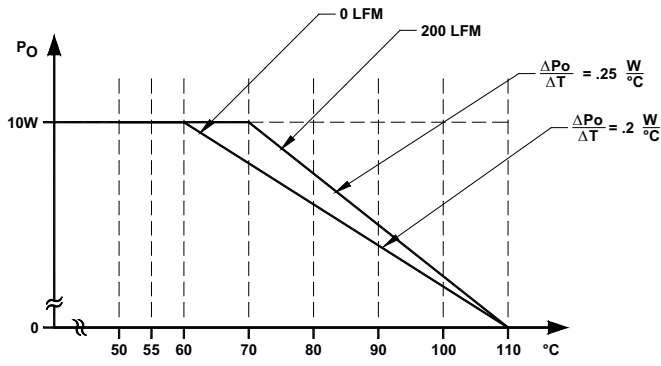

FIGURE 4. Derating of BD10018

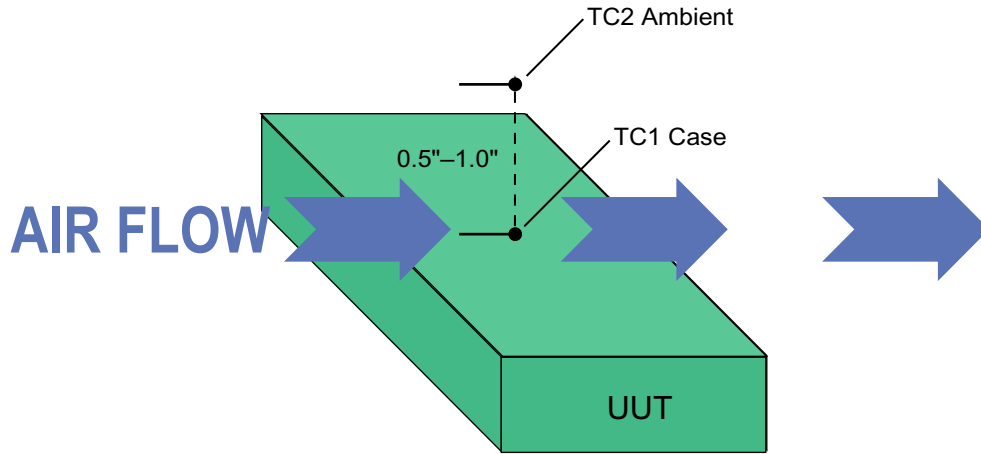

FIGURE 5. Setup for measuring case and ambient temperatures

The ambient temperature is measured with thermo-coupler #2, which is positioned 0.5"-1.0" above the center of the unit. When airflow is used, position the converter such that the 2" length of the converter is perpendicular to the airflow.