



BD11000

11W WIDE RANGE
DC/DC CONVERTER

Key Features

- 50 μ S transient response
- Efficiency up to 83%
- Input-to-output isolation
- Soft start
- Triple output
- Short circuit protection
- 500 μ A off-state current
- Wide input voltage range (4:1)
- Synchronization
- Designed to be compliant with UL 1950 and CSA 22.2 950

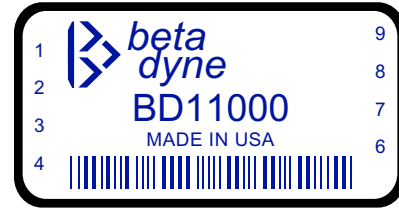

Functional Description

The BD11000 DC/DC converter accepts 23V_{IN} to 72V_{IN} and provides 5V_{OUT}@2A and \pm 12V_{OUT}@30mA. Forward topology and a 400kHz switching frequency allows the converter to operate efficiently over a 4:1 input voltage range. The converter is designed to meet all UL and CSA safety standards and the six-sided shielding drastically reduces conducted and radiated noise. With the addition of few external components, the BD11000 passes FCC and VDE specifications for conducted and radiated noise.

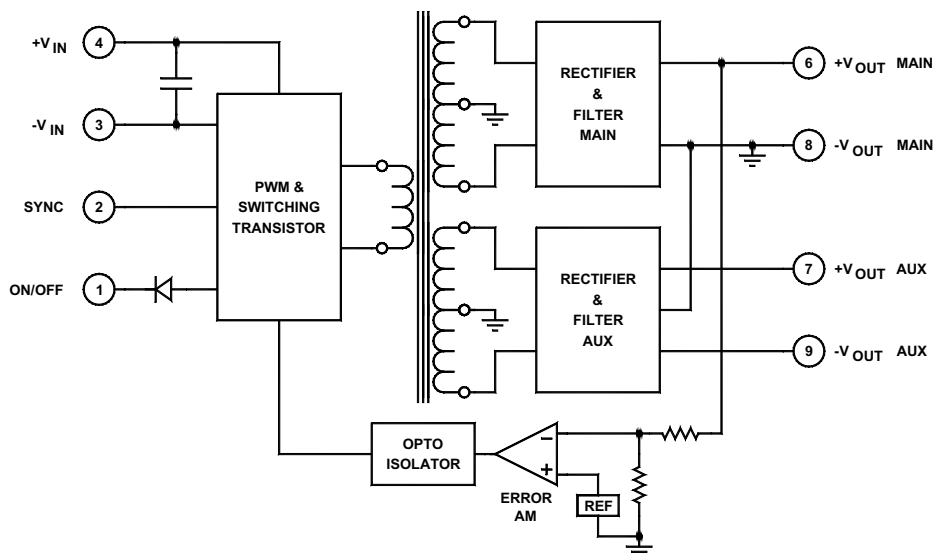

Typical Block Diagram

Electrical Specifications

INPUT SPECIFICATIONS

Unless otherwise specified, all parameters are given under typical +25°C with nominal input voltage and under full output load conditions.

PARAMETER	CONDITION / NOTE	MIN	TYP	MAX	UNIT
Input Voltage Range		23	48	75	Vdc
Input Filter	C				
Reverse Polarity	External series-blocking diode				
No Load Input Current			18		mA
Input Surge Current (20µS Spike)				10	A
Short Circuit Current Limit			150		% I _{IN}
Undervoltage Shutdown			8		Vdc
Off State Current			75		µA
Remote ON/OFF Control					
Supply ON	Open ON/OFF Pin (Open circuit voltage: 12V Max.)		5.5		Vdc
Supply OFF		0		0.8	Vdc
Logic Input Reference	-Input				
Logic Compatibility	TTL Open Collector or CMOS Open Drain				
Converter Standby Input Current			8		mA

OUTPUT SPECIFICATIONS

PARAMETER	CONDITION / NOTE	MIN	TYP	MAX	UNIT
Voltage, Main		4.75	5.00	5.25	Vdc
Voltage, Auxiliary		±11.4	±12.0	±12.6	Vdc
Current, Main		0.5		2.0	A
Current, Auxiliary			25	50	mA
Output Voltage Accuracy, Main			±1		%
Output Voltage Accuracy, Auxiliary			3	±5	%
Output Voltage Adjustment	Single only		3	±5	%
Voltage Balance, Auxiliary	Balanced loads for auxiliary		±2		%
Minimum Load		10			% of FL
Ripple & Noise			1	2	%V _{PP} of V _{OUT}
Line Regulation, Main	Minimum V _{IN} to maximum V _{IN}		±1	2	%
Line Regulation, Auxiliary	Minimum V _{IN} to maximum V _{IN}		±5	5	%
Load Regulation, Main	NL to FL		±1		%
Load Regulation, Auxiliary	Main Fully Loaded (See Figure 1)			±5	%
Temperature Coefficient @ FL			0.02		%/°C
Transient Recovery Time (to within ±1%)	50% FL to FL to 50% FL		50	100	µS
Short Circuit Protection	All outputs, by input current limiting				
Output Short Circuit Duration	Continuous				

GENERAL SPECIFICATIONS

PARAMETER	CONDITION / NOTE	MIN	TYP	MAX	UNIT
Efficiency (at full power)		72	83	85	%
Isolation Voltage (1 min.)			1500		Vdc
Isolation Resistance			10 ⁹		Ω
Isolation Capacitance			80		pF
Switching Frequency			400		kHz

ENVIRONMENTAL SPECIFICATIONS

PARAMETER	CONDITION / NOTE	MIN	TYP	MAX	UNIT
		-40		+71	°C
		-55		+85	°C
Storage Temperature Range		-55		+125	°C
Thermal Resistance			10		°C/W _{DISS}
Derating	None				
Cooling	Free-air convection				
EMI/RFI	Six-sided continuous shielded metal case				
MTBF	per MIL-HNBK-217F (Ground benign, +25°C)		984,828		hours

PHYSICAL CHARACTERISTICS

PARAMETER	CONDITION / NOTE	MIN	TYP	MAX	UNIT
Dimensions (L×W×H)	2.00×1.00×0.395 in. (50.80×25.40×10.03mm)				
Weight	1.04 oz. (30g)				
Case Material	Coated metal				
Shielding Connection	Output Ground				

EXTERNAL SYNCHRONIZATION

The BD11000 can be synchronized to an external TTL or CMOS clock signal. Insert a 1000pF ceramic capacitor between the driving clock signal and the SYNC pin (Pin 2) of the converter. The frequency of the signal must be 370kHz to 450kHz and the duty cycle 20% low and 80% high.

See our application notes:

DC-001: Testing Transient Response in DC/DC Converters

DC-002: Common-mode Filters for DC/DC Converters

EMI/RFI

The BD11000 is designed to pass FCC Class A radiated noise. With the addition of external filtering, it will pass FCC Class A, B and VDE conducted and radiated noise specifications (see Application Note).

