



BD15004

15W DC/DC CONVERTER

Adjustable output: $3.3V_{OUT}$ to $5V_{OUT}$

Key Features

- $30V_{IN}$ to $52V_{IN}$ range
- Efficiency up to 87%
- Input-to-output isolation
- Soft start
- Short circuit current limit
- 1mA off state current
- Multiple converter synchronization
- Output overvoltage protection (OVP)



Functional Description

The BD15004 is a single adjustable output DC/DC converter with an input voltage range from $30V_{IN}$ to $52V_{IN}$ and an output voltage range from $3.3V_{OUT}$ to $5V_{OUT}$. It features a 400kHz switching frequency, forward topology, and a case size of $2 \times 1 \times 0.395$ -inch with industry standard pinout arrangement. Synchronous rectification improves efficiency, while the six-sided shielding, SMD and improved thermal techniques guarantee reliability.

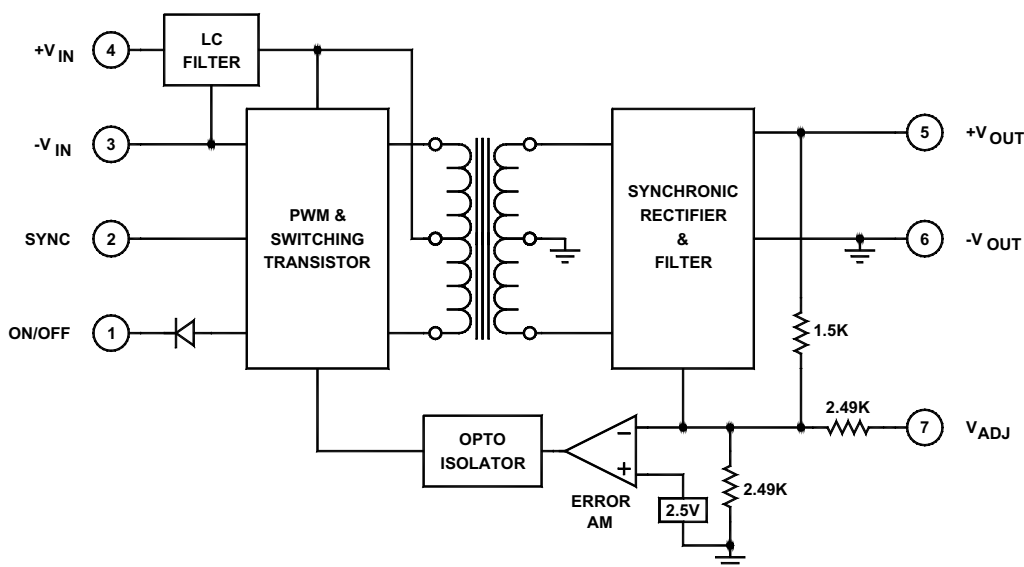

Typical Block Diagram

Electrical Specifications

INPUT SPECIFICATIONS

Unless otherwise specified, all parameters are given under typical +25°C with nominal input voltage and under full output load conditions.

PARAMETER	CONDITION / NOTE	MIN	TYP	MAX	UNIT
Input Voltage Range		30	42	52	Vdc
Input Startup Voltage	42V _{IN}	7			Vdc
Input Current, Full Load	42V _{IN} , V _{OUT} = 4V@3.75A		420		mA
Input Current, No Load	42V _{IN}		20		mA
Undervoltage Shutdown	42V _{IN}		6		Vdc
Input Filter	LC				
Reverse Polarity	External series-blocking diode				
Input Surge Current (20µS Spike)				10	A
Short Circuit Current Limit			150		% I _N Nominal
Off State Current			1		mA
Remote ON/OFF Control					
Supply ON	Pin 1 Open (Open circuit voltage: 12V Max.)				
Supply OFF		0		0.8	Vdc
Logic Input Reference	-Input for ON/OFF and SYNC				
Logic Compatibility	TTL Open Collector or CMOS Open Drain				

OUTPUT SPECIFICATIONS

PARAMETER	CONDITION / NOTE	MIN	TYP	MAX	UNIT
Voltage Ratings		3.3	4	5	Vdc
Current Ratings				3	A
Output Voltage Accuracy			±1		%
Output Voltage Adjustment		-18		+25	%
Minimum Load	0% for Single output				% of FL
Ripple & Noise			1	2	%V _{PP} of V _{OUT}
Line Regulation	Minimum V _{IN} to maximum V _{IN}		±0.5	1	%
Load Regulation	NL to FL		±1		%
Temperature Coefficient @ FL			0.02		%/°C
Transient Response Time	50% FL to FL to 50% FL, See Figure 3		100	150	µS
Short Circuit Protection	All outputs, by input current limiting				
Turn On Delay with Soft Start	See Figure 3		2		mS
Output Overvoltage Protection			130	150	% of V _{OUT}

GENERAL SPECIFICATIONS

PARAMETER	CONDITION / NOTE	MIN	TYP	MAX	UNIT
Efficiency	5V@3A		87		%
Efficiency	4V@3.75A		85		%
Efficiency	3.3V@4.5A		80		%
Isolation Voltage (1 min.), Input to Output			1500		Vdc
Isolation Resistance			10 ⁹		Ω
Isolation Capacitance			500		pF
Switching Frequency			400		kHz

ENVIRONMENTAL SPECIFICATIONS

PARAMETER	CONDITION / NOTE	MIN	TYP	MAX	UNIT
Operating Temperature, Industrial (Ambient)	See Figure 1	-40		+71	°C
Operating Temperature, Extended		-55		+85	°C
Storage Temperature Range		-55		+125	°C
Thermal Resistance				7.4	°C/W _{DISS}
Maximum Operating Case Temperature				100	°C
Derating	See Figure 1				
Humidity	Up to 95% non-condensing				
Cooling	Free-air convection				
EMI/RFI	Six-sided continuous shielded metal case				
MTBF	per MIL-HNBK-217F (Ground benign, +25°C)		1.1×10 ⁶		hours

PHYSICAL CHARACTERISTICS

PARAMETER	CONDITION / NOTE	MIN	TYP	MAX	UNIT
Dimensions (L×W×H)	2.00×1.00×0.395 in. (50.80×25.40×10.03mm)				
Weight	1.06 oz. (30.3g)				
Case Material	Coated metal				
Shielding Connection	+V _{IN} Input (Pin 4)				

EXTERNAL SYNCHRONIZATION

The converter can be synchronized to an external TTL or CMOS clock signal. Insert a 470pF to 1000pF ceramic capacitor between the driving clock signal and the SYNC pin (Pin 2) of the convertor. The frequency of the signal must be between 390kHz and

430kHz, with a duty cycle of 50% and an amplitude between 3Vdc minimum and 5Vdc typical.

See Application Note DC-005: Synchronization.

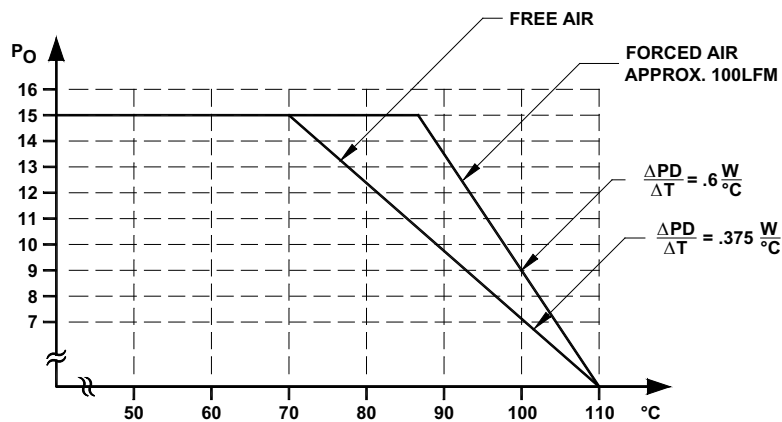

FIGURE 1. Worst case derating of BD15004

TABLE 1. Minimum input operating voltage range for BD15004

V _{IN} (V _{ADJ})	V _O
0.00	5.512
1.00	4.910
2.00	4.308
3.00	3.706
3.67	3.300

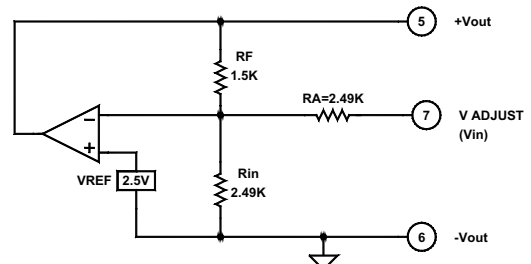

FIGURE 2. Error amplifier of BD15004

V_{REF}=2.5V; R_F, R_{IN}, R_A have 1% accuracy

V_O = 5.512 - 0.602V_{IN} (V_{ADJ})

Approximate values are given in Table 2

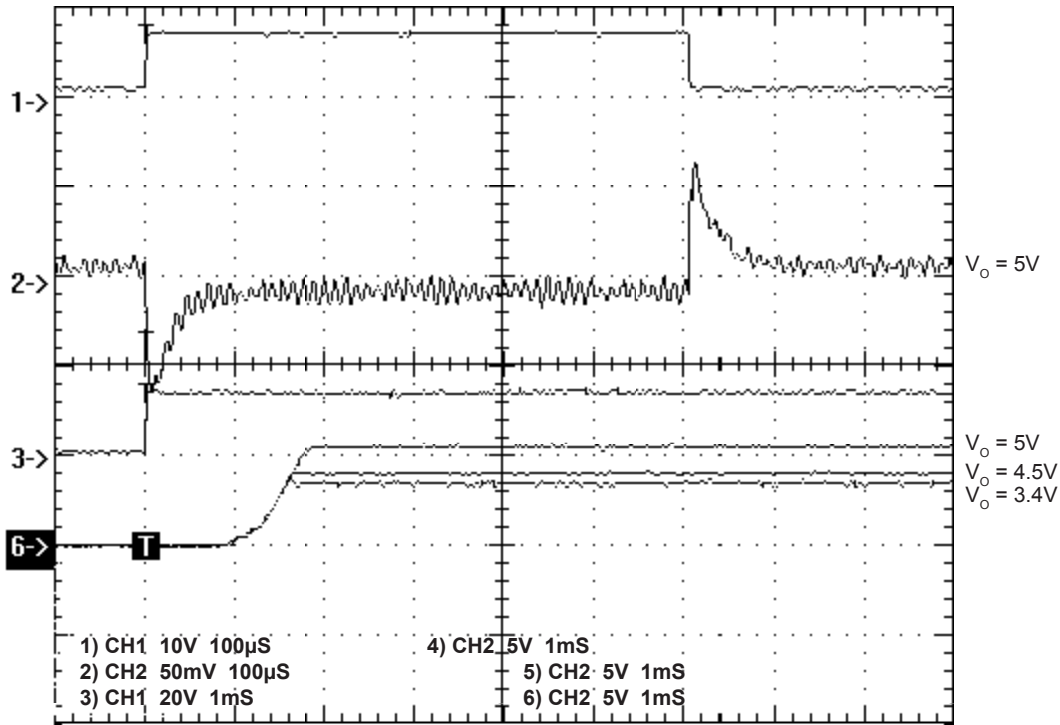

FIGURE 3. Transient response and turn on delay with soft start of BD15004

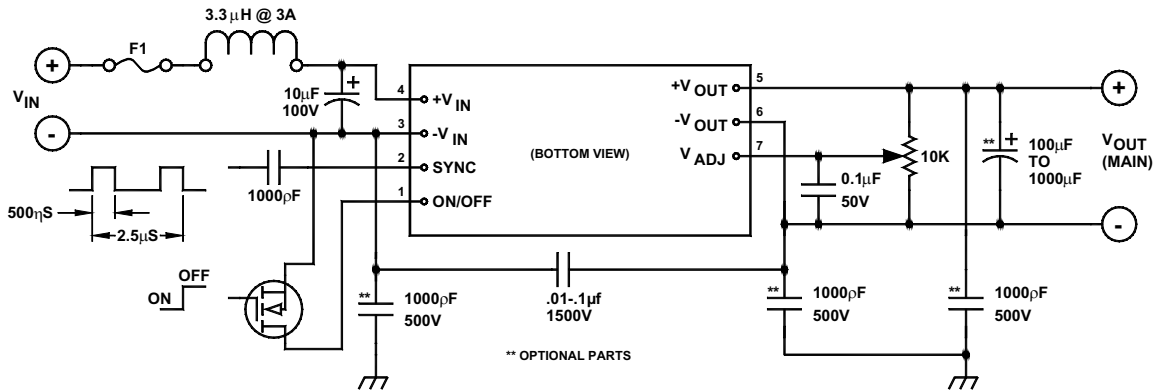

FIGURE 4. Typical connection diagram of a BD15004 single output DC/DC converter

