



BD15012B

20W DUAL DC/DC CONVERTER
 $36-75V_{IN}$, $7V_{OUT}@2A$ & $5V_{OUT}@1.2A$
 Dual Isolated

Key Features

- Wide input voltage range (2:1)
- 83% efficiency
- Input-to-output isolation
- Soft start
- Short circuit protection
- 150 μ A off state current
- Multiple converter synchronization
- Dual isolated output
- Output overvoltage protection (OVP)



Functional Description

The BD15012B is a dual output DC/DC converter that accepts $36-75V_{IN}$ and provides two isolated outputs: $7V_{OUT}@2A$ and $5V_{OUT}@1.2A$. The converter features 2:1 input voltage range, 300kHz switching frequency, forward topology and come packaged in a $2 \times 1 \times 0.395$ -inch case with an industry standard pin out arrangement. Six-sided shielding, SMD and improved thermal techniques guarantee reliability. The converter will synchronize to an external clock frequency of 310kHz or higher.

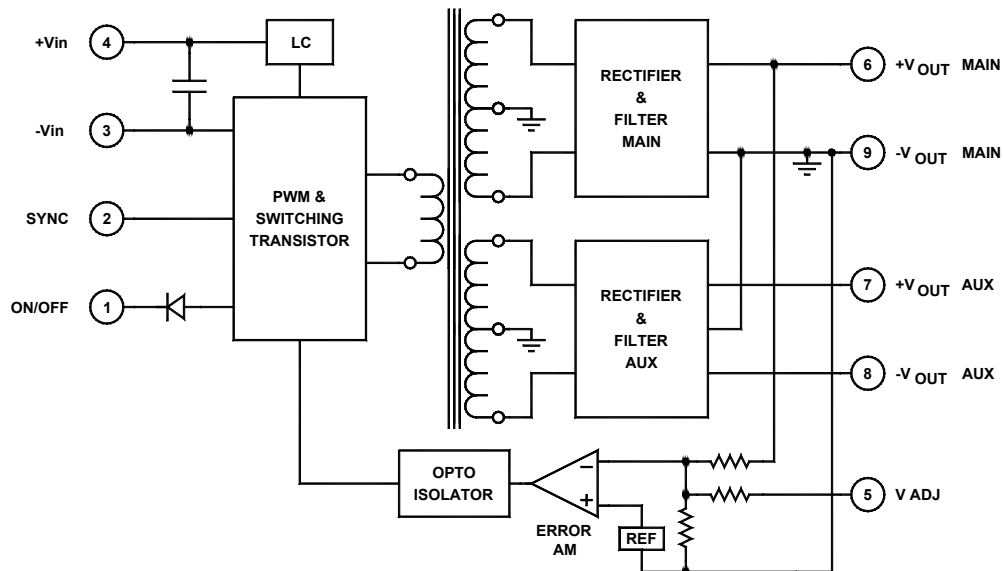

Typical Block Diagram (Dual Isolated Output)

Electrical Specifications

INPUT SPECIFICATIONS

Unless otherwise specified, all parameters are given under typical +25°C with nominal input voltage and under full output load conditions.

PARAMETER	CONDITION / NOTE	MIN	TYP	MAX	UNIT
Input Voltage Range		36	48	75	Vdc
Input Startup Voltage		12			Vdc
Input Filter	LC				
Reverse Polarity	External series-blocking diode				
No Load Input Current			10		mA
Full Load Input Current			502		mA
Input Surge Current (20µS Spike)				10	A
Short Circuit Current Limit			150		% I _{IN}
Off State Current			150		µA
Remote ON/OFF Control					
Supply ON	Pin 1 Open (Open circuit voltage: 12V Max.)				
Supply OFF		0		0.8	Vdc
Logic Input Reference	-Input for ON/OFF and SYNC				
Logic Compatibility	TTL Open Collector or CMOS Open Drain				
Sync Frequency	Amplitude of 3.3V to 5V	310	340	360	kHz

OUTPUT SPECIFICATIONS

PARAMETER	CONDITION / NOTE	MIN	TYP	MAX	UNIT
Output Voltage, V _{O1}	V _{O1} = 7Vdc		7		Vdc
Output Voltage Accuracy, V _{O1}	Fully loaded		±2	±5	%
Output Voltage Adjustment, V _{O1}	V REF to -V _{O1}		5		%
Output Voltage, V _{O2}	V _{O2} = 5Vdc		5		Vdc
Output Voltage Accuracy, V _{O2}	Fully loaded		±2	±5	%
Output Voltage Adjustment, V _{O2}	V _{O2} track V _{O1}		5		%
Minimum Load	0% for V _{O1} , 10% for V _{O2}				% of FL
Ripple & Noise			1	2	%V _{PP} of V _{OUT}
Line Regulation, V _{O1}	Minimum V _{IN} to maximum V _{IN}		±0.5	1	%
Line Regulation, V _{O2}	V _{O1} and V _{O2} fully loaded		±3	±5	%
Load Regulation, V _{O1}	NL to FL		±1		%
Load Regulation, Dual Isolated	See Figures 4 & 6		±2	±5	%
Temperature Coefficient @ FL			0.02		%/°C
Transient Response Time	50% FL to FL to 50% FL		100	150	µS
Short Circuit Protection	All outputs, by input current limiting				
Turn On Delay with Soft Start			2		mS
Output Overvoltage Protection			130	150	% of V _{OUT}

GENERAL SPECIFICATIONS

PARAMETER	CONDITION / NOTE	MIN	TYP	MAX	UNIT
Efficiency (at full power)	V _{IN} = 48Vdc		83		%
Isolation Voltage (1 min.), Input to Output			1500		Vdc
Isolation Voltage, Output to Output	Dual only		500		Vdc
Isolation Resistance			10 ⁹		Ω
Isolation Capacitance			500		pF
Switching Frequency			300		kHz

ENVIRONMENTAL SPECIFICATIONS

PARAMETER	CONDITION / NOTE	MIN	TYP	MAX	UNIT
Operating Temperature, Industrial		-40		+60	°C
Storage Temperature Range		-55		+125	°C
Thermal Resistance				7.4	°C/W _{DISS}
Maximum Operating Case Temperature				100	°C
Derating	None required				
Humidity	Up to 95% non-condensing				
Cooling	Free-air convection				
EMI/RFI	Six-sided continuous shielded metal case				
MTBF	per MIL-HNBK-217F (Ground benign, +25°C)		1.1×10 ⁶		hours

PHYSICAL CHARACTERISTICS

PARAMETER	CONDITION / NOTE	MIN	TYP	MAX	UNIT
Dimensions (L×W×H)	2.00×1.00×0.395 in. (50.08×25.40×10.03mm)				
Weight	1.06 oz. (30.3g)				
Case Material	Coated metal				
Shielding Connection	-Input (Pin 3)				

EXTERNAL SYNCHRONIZATION

The converters can be synchronized to an external TTL or CMOS clock signal. Insert a 100pF ceramic capacitor between the driving clock signal and the SYNC pin (Pin 2) of the converter. The

frequency of the signal must be between 310kHz and 360kHz, with a duty cycle of 50% and an amplitude between 3Vdc minimum and 5Vdc typical. See Application Note DC-005: Synchronization.

EXTERNAL TRIMMING OF OUTPUT VOLTAGES (SINGLE AND DUAL ONLY)

To trim the output voltage DOWN, connect a 1% 1/8W resistor between the + (positive) output and trim pin of the converter. To trim the output voltage UP, connect a 1% 1/8W resistor between the - (negative) output and trim pins of the converter. For UP/DOWN trimming capability, connect a 10kΩ potentiometer between the + and - output pins, with the wiper arm connected to the trim pin.

The trim resistors/potentiometer can be connected at the converter output pins or the load. However, if connected at the load,

the resistance of the runs becomes part of the feedback network which improves load regulation. If the load is some distance from the converter, the use of #20 gauge wire is recommended to avoid excessive voltage drop due to the resistance of the circuit paths.

See our application notes:

DC-001: Testing Transient Response in DC/DC Converters
DC-004: Thermal Consideration for DC/DC Converters

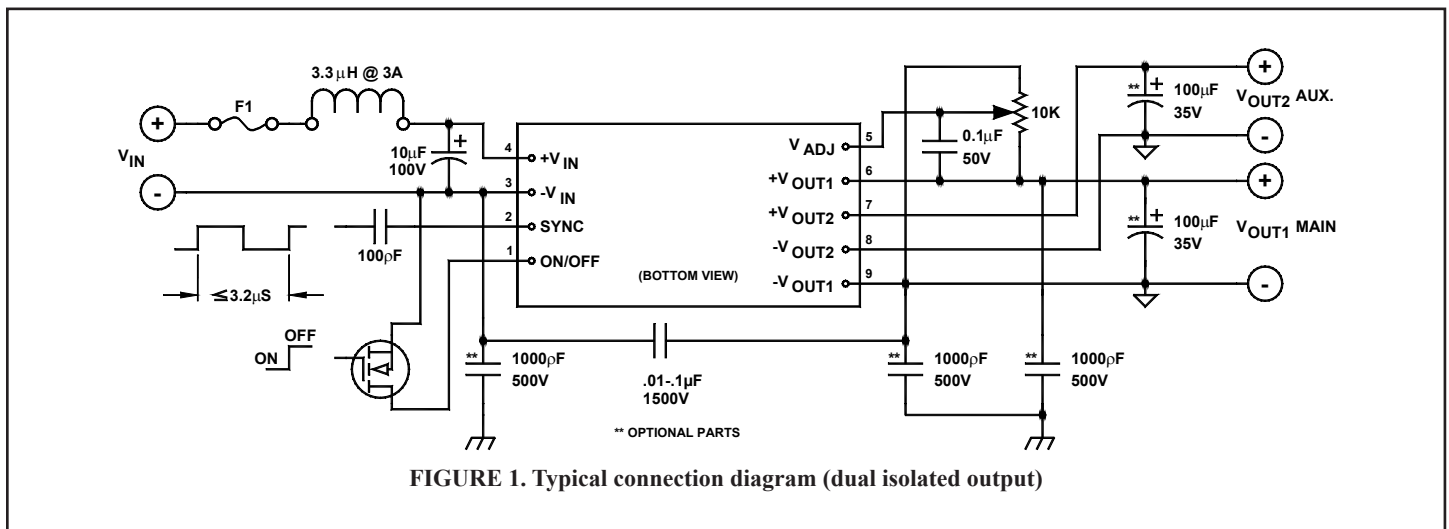

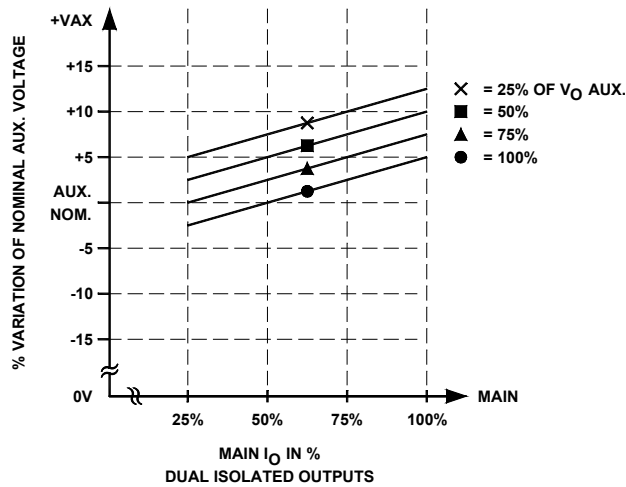

FIGURE 2. Graph of typical load regulation of a dual isolated output. Variation in % of V_{AUX} vs. Main output loading.

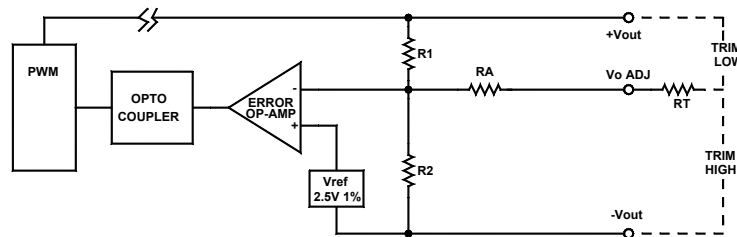

FIGURE 3. Output control circuit

To trim V_o higher to V_o' , where V_o is the actual measured value:

$$RT = \frac{R1 \cdot V_{REF}}{V_o' - V_o}$$

To trim V_o lower to V_o'' , where V_o is the actual measured value:

$$RT = \left[\left(\frac{R_1^2 \cdot V_{REF}}{R_2 \cdot (V_o - V_o'')} - R1 \right) RA \right]$$

Resistor	Value (K)
R1	7.5
R2	4.12
RA	10

MECHANICAL SPECIFICATIONS

in inches [mm]

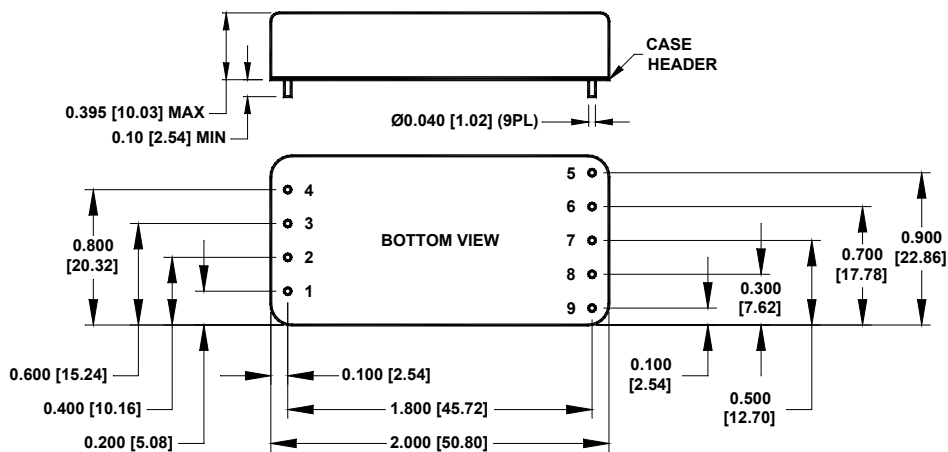

Pin	Function
	DUAL ISOLATED
1	ON/OFF
2	SYNC
3	$-V_{IN}$
4	$+V_{IN}$
5	V_{ADJ}
6	$+V_{O1}$ (MAIN)
7	$+V_{O2}$ (AUX)
8	$-V_{O2}$ (AUX)
9	$-V_{O1}$ (MAIN)