



BD15014

15W SINGLE DC/DC CONVERTER

$18-36V_{IN}$ $48V_{OUT}@400mA$

Key Features

- 2:1 input voltage range
- 88% efficiency
- Input-to-output isolation
- Soft start
- Short circuit protection
- $150\mu A$ off state current
- Multiple converter synchronization
- Output overvoltage protection (OVP)



Functional Description

The BD15014 is a 20W single output DC/DC converter with an input voltage range of $18V_{IN}$ to $36V_{IN}$ and an output voltage of $48V_{OUT}@400mA$ with an adjustable output range up to $\pm 10\%$. The converter features a 200kHz switching frequency, forward topology and a $2 \times 1 \times 0.395$ -inch package size with an industry standard pinout arrangement.

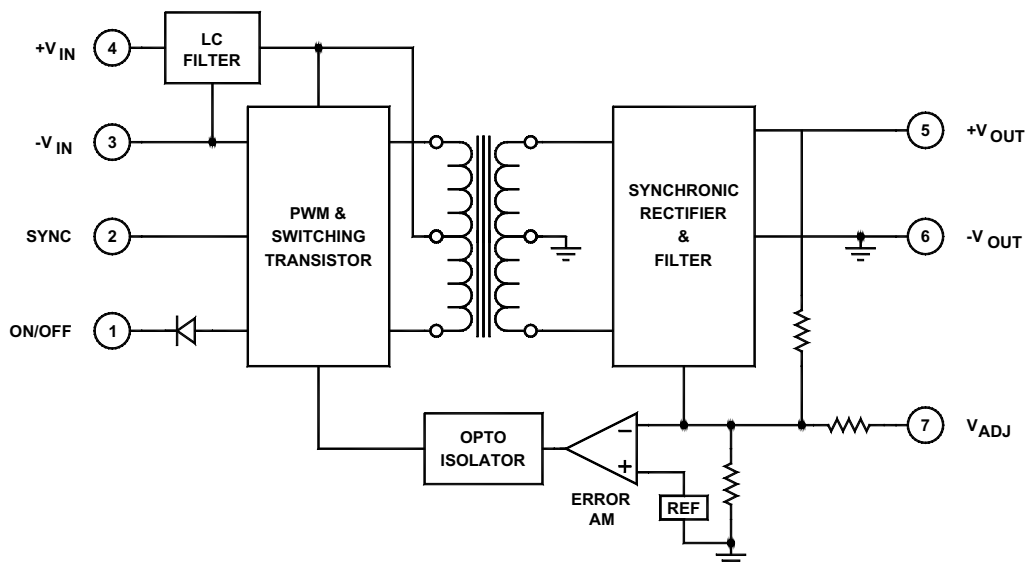

Typical Block Diagram

Unless otherwise specified, all parameters are given under typical +25°C with nominal input voltage and under full output load conditions.

Electrical Specifications

INPUT SPECIFICATIONS

PARAMETER	CONDITION / NOTE	MIN	TYP	MAX	UNIT
Input Voltage Range		18	24	36	Vdc
Input Startup Voltage, 24V _{IN}		7			Vdc
No Load Input Current, 24V _{IN}			40		mA
Full Load Input Current, 24V _{IN}	P _O = 20W		930		mA
Input Filter	LC				
Reverse Polarity	External series-blocking diode				
Input Surge Current (20μS Spike)				10	A
Short Circuit Current Limit			150		% I _N Nominal
Off State Current			150		μA
Remote ON/OFF Control					
Supply ON	Pin 1 Open (Open circuit voltage: 12V Max.)				
Supply OFF		0		0.8	Vdc
Logic Input Reference	-Input for ON/OFF and SYNC				
Logic Compatibility	TTL Open Collector or CMOS Open Drain				

OUTPUT SPECIFICATIONS

PARAMETER	CONDITION / NOTE	MIN	TYP	MAX	UNIT
Output Voltage			48		Vdc
Output Current			400		mA
Output Voltage Accuracy			±1.5		%
Output Voltage Adjustment			±5	±10	%
Minimum Load	0% for Single output				% of FL
Ripple & Noise	C _O = 33μF		0.5	1	%V _{PP} of V _{OUT}
Line Regulation	Minimum V _{IN} to maximum V _{IN}		±0.5	1	%
Load Regulation	NL to FL		±1		%
Temperature Coefficient @ FL			0.02		%/°C
Transient Response Time	50% FL to FL to 50% FL		100	150	μS
Short Circuit Protection	All outputs, by input current limiting				
Turn On Delay with Soft Start			2		mS
Output Overvoltage Protection			130	150	% of V _{OUT}

GENERAL SPECIFICATIONS

PARAMETER	CONDITION / NOTE	MIN	TYP	MAX	UNIT
Efficiency (at full power)			88		%
Isolation Voltage (1 min.), Input to Output			1500		Vdc
Isolation Resistance			10 ⁹		Ω
Isolation Capacitance			500		pF
Switching Frequency			200		kHz

ENVIRONMENTAL SPECIFICATIONS

PARAMETER	CONDITION / NOTE	MIN	TYP	MAX	UNIT
Operating Temperature, Case		-40		+100	°C
Operating Temperature, Extended		-55		+85	°C
Storage Temperature Range		-55		+125	°C
Thermal Resistance				7.4	°C/W _{DISS}
Maximum Operating Case Temperature				100	°C
Derating	See Figure 1				
Humidity	Up to 95% non-condensing				
Cooling	Free-air convection				
EMI/RFI	Six-sided continuous shielded metal case				
MTBF	per MIL-HNBK-217F (Ground benign, +25°C)		1.1×10 ⁶		hours

PHYSICAL CHARACTERISTICS

PARAMETER	CONDITION / NOTE	MIN	TYP	MAX	UNIT
Dimensions (L×W×H)	2.00×1.00×0.395 in. (50.80×25.40×10.03mm)				
Weight	1.06 oz. (30.3g)				
Case Material	Coated metal				
Shielding Connection, 24V _{IN}	-Input Ground (Pin 3)				

EXTERNAL SYNCHRONIZATION

The converter can be synchronized to an external TTL or CMOS clock signal. Insert a 470pF to 1000pF ceramic capacitor between the driving clock signal and the SYNC pin (Pin 2) of the

converter. The frequency of the signal must be between 390kHz and 430kHz, with a duty cycle of 50% and an amplitude between 3Vdc minimum and 5Vdc typical. See Application Note DC-005:

EXTERNAL TRIMMING OF OUTPUT VOLTAGES (SINGLE ONLY)

To trim the output voltage DOWN, connect a 5% ¼W resistor between the + (positive) output and trim pin of the converter. To trim the output voltage UP, connect a 5% ¼W resistor between the – (negative) output and trim pins of the converter. For UP/DOWN trimming capability, connect a 10kΩ potentiometer between the + and – output pins, with the wiper arm connected to the trim pin.

The trim resistors/potentiometer can be connected at the converter output pins or the load. However, if connected at the load,

the resistance of the runs becomes part of the feedback network which improves load regulation. If the load is some distance from the converter, the use of #20 gauge wire is recommended to avoid excessive voltage drop due to the resistance of the circuit paths.

See our application notes:

- DC-001: Testing Transient Response in DC/DC Converters
- DC-004: Thermal Consideration for DC/DC Converters

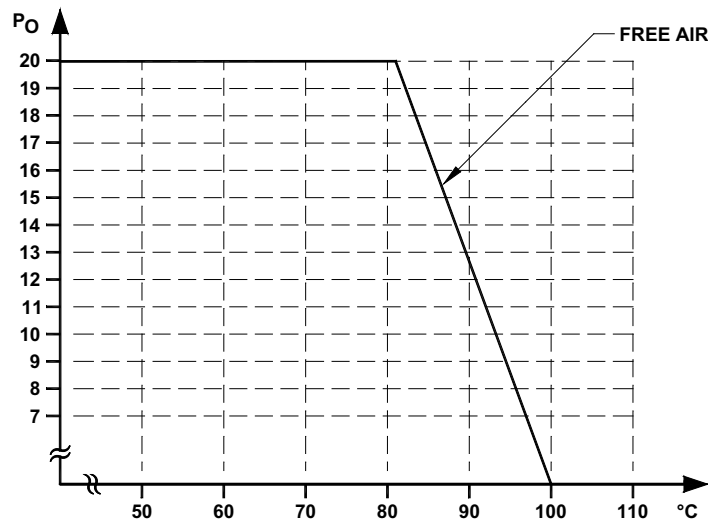

FIGURE 1. Derating curve for ambient temperature

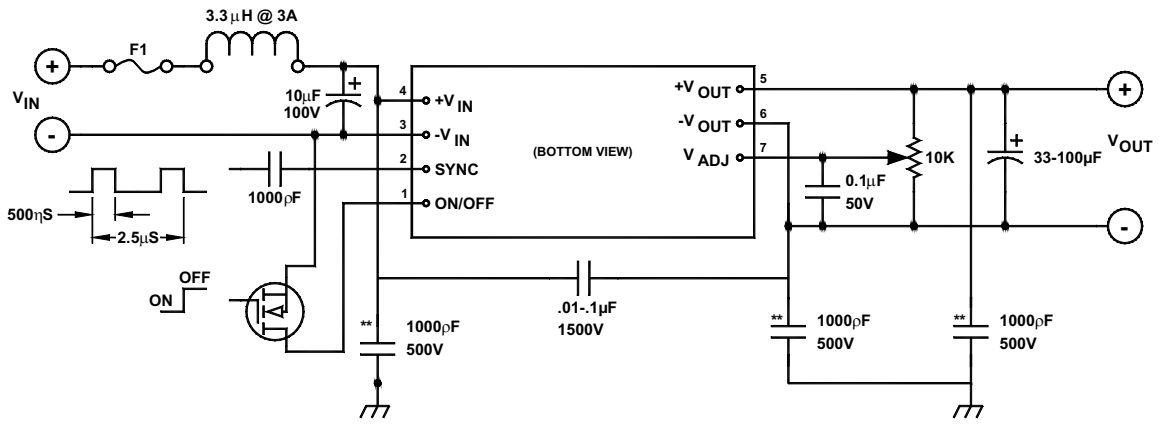
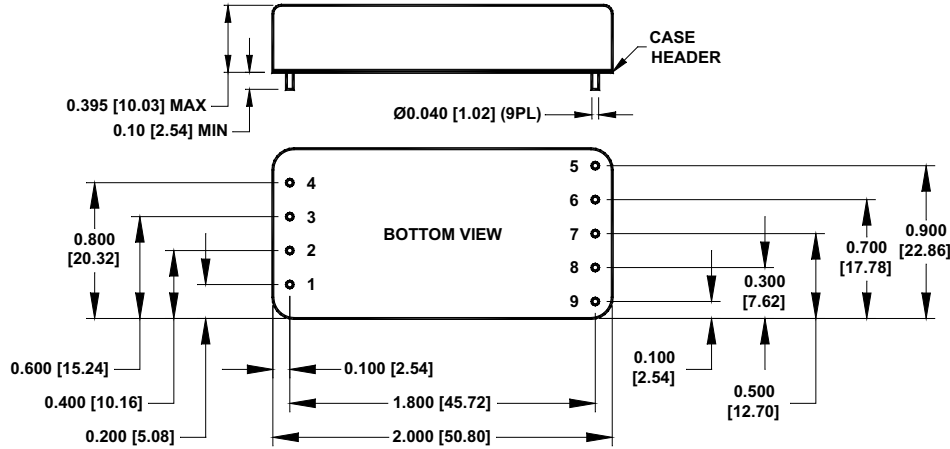

FIGURE 2. Typical connection diagram (single output)

MECHANICAL SPECIFICATIONS
in inches [mm]



Pin	Function
1	ON/OFF
2	SYNC
3	-V _{IN}
4	+V _{IN}
5	+OUTPUT
6	-OUTPUT
7	+V _{ADJ}
8	No Pin
9	No Pin