



# BD15019

## 15W DC/DC TRIPLE CONVERTER

### Key Features

- Wide input voltage range (2:1)
- Efficiency up to 80%
- Input-to-output isolation
- Soft start
- Short circuit protection
- 150 $\mu$ A off state current
- Multiple converter synchronization
- Dual isolated output
- Output overvoltage protection (OVP)



Beta Dyne is protected under various patents, including but not limited to U.S. Patent numbers: 5,777,519; 6,188,276; 6,262,901; 6,452,818; 6,473,3171.

### Functional Description

The BD15019 is a triple output DC/DC converter that offers 2:1 input voltage range, 400kHz switching frequency, forward topology and come packaged in a 2 $\times$ 1 $\times$ 0.395-inch case with an industry standard pin out arrangement. Six-sided shielding, SMD and improved thermal techniques guarantee reliability.

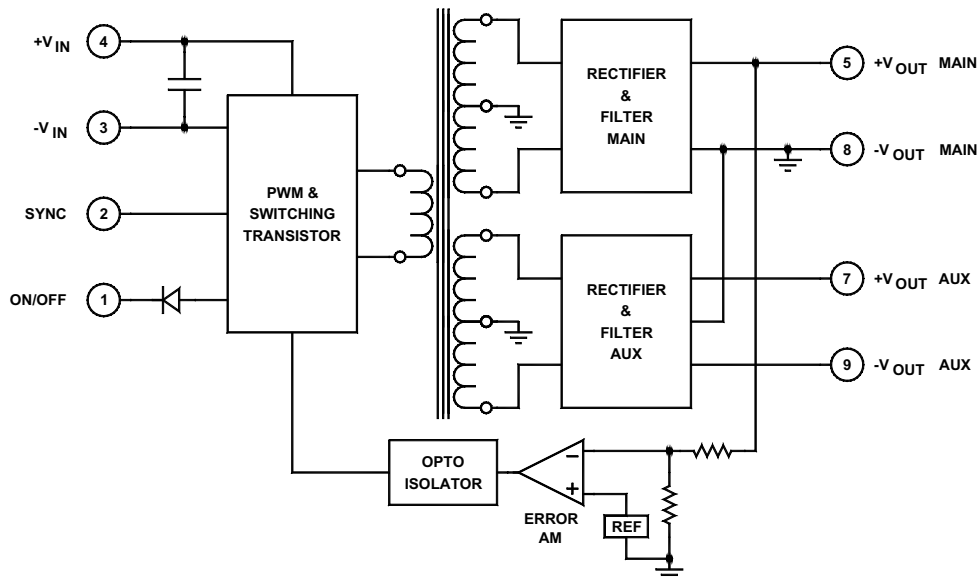

Typical Block Diagram (Triple Output)

## Electrical Specifications

### INPUT SPECIFICATIONS

Unless otherwise specified, all parameters are given under typical +25°C with nominal input voltage and under full output load conditions.

PARAMETER	CONDITION / NOTE	MIN	TYP	MAX	UNIT
Input Voltage Range		36	48	72	Vdc
Input Startup Voltage, 48V <sub>IN</sub>		12			Vdc
Undervoltage Shutdown	48V <sub>IN</sub> = 11Vdc		8		Vdc
Input Filter	LC				
Reverse Polarity	External series-blocking diode				
No Load Input Current			20		mA
Full Load Input Current			390		mA
Input Surge Current (20μS Spike)				10	A
Short Circuit Current Limit			150		% I <sub>IN</sub>
Off State Current			150		μA
Remote ON/OFF Control					
Supply ON	Pin 1 Open (Open circuit voltage: 12V Max.)				
Supply OFF		0		0.8	Vdc
Logic Input Reference	-Input for ON/OFF and SYNC				
Logic Compatibility	TTL Open Collector or CMOS Open Drain				
Main Voltage Rating			5.6		V
Main Output Current					mA
Auxiliary Voltage Rating					V
Auxiliary Output Current					mA

### OUTPUT SPECIFICATIONS

PARAMETER	CONDITION / NOTE	MIN	TYP	MAX	UNIT
Output Voltage (Main)			5.6		V
Output Current (Main)			1350		mA
Output Voltage (Auxiliary)			±15		V
Output Current (Auxiliary)			±250		mA
Output Voltage Accuracy, Triple (Main)			±1		%
Output Voltage Accuracy, Triple (Auxiliary)			3	±5	%
Voltage Balance, Triple (Auxiliary)	Balanced loads for auxiliary			±2	%
Minimum Load	0% for main output, 10% for auxiliary output				% of FL
Ripple & Noise			1	2	%V <sub>PP</sub> of V <sub>OUT</sub>
Line Regulation, Triple (Main)	Minimum V <sub>IN</sub> to maximum V <sub>IN</sub>		±1	2	%
Line Regulation, Triple (Aux)	With balanced loads		±5	5	%
Load Regulation, Triple (Main)	Main fully loaded		±1		%
Load Regulation, Triple (Auxiliary)	See Figure 6		±5		%
Temperature Coefficient @ FL			0.02		%/°C
Transient Response Time	50% FL to FL to 50% FL		100	150	μS
Short Circuit Protection	All outputs, by input current limiting				
Turn On Delay with Soft Start			2		mS
Output Overvoltage Protection			130	150	% of V <sub>OUT</sub>

### GENERAL SPECIFICATIONS

PARAMETER	CONDITION / NOTE	MIN	TYP	MAX	UNIT
Efficiency (at full power)			80		%
Isolation Voltage (1 min.), Input to Output			1500		Vdc
Isolation Resistance			10 <sup>9</sup>		Ω
Isolation Capacitance			500		pF
Switching Frequency			400		kHz
Auxiliary Voltage			+15		V
Auxiliary Current			250		mA

**ENVIRONMENTAL SPECIFICATIONS**

PARAMETER	CONDITION / NOTE	MIN	TYP	MAX	UNIT
Operating Temperature, Industrial (Ambient)	See Figure 1	-40		+71	°C
Operating Temperature, Extended		-55		+85	°C
Storage Temperature Range		-55		+125	°C
Thermal Resistance				7.4	°C/W <sub>DISS</sub>
Maximum Operating Case Temperature				100	°C
Derating	See Figure 1				
Humidity	Up to 95% non-condensing				
Cooling	Free-air convection				
EMI/RFI	Six-sided continuous shielded metal case				
MTBF	per MIL-HNBK-217F (Ground benign, +25°C)		1.1×10 <sup>6</sup>		hours

**PHYSICAL CHARACTERISTICS**

PARAMETER	CONDITION / NOTE	MIN	TYP	MAX	UNIT
Dimensions (L×W×H)	2.00×1.00×0.395 in. (50.80×25.40×10.03mm)				
Weight	1.06 oz. (30.3g)				
Case Material	Coated metal				
Shielding Connection, 24V <sub>IN</sub>	-Input Ground (Pin 3)				
Shielding Connection, 48V <sub>IN</sub>	+Input (Pin 4)				

**EXTERNAL SYNCHRONIZATION**

The converters can be synchronized to an external TTL or CMOS clock signal. Insert a 470pF to 1000pF ceramic capacitor between the driving clock signal and the SYNC pin (Pin 2) of the converter. The frequency of the signal must be between 390kHz

and 430kHz, with a duty cycle of 50% and an amplitude between 3Vdc minimum and 5Vdc typical. See Application Note DC-005: Synchronization.

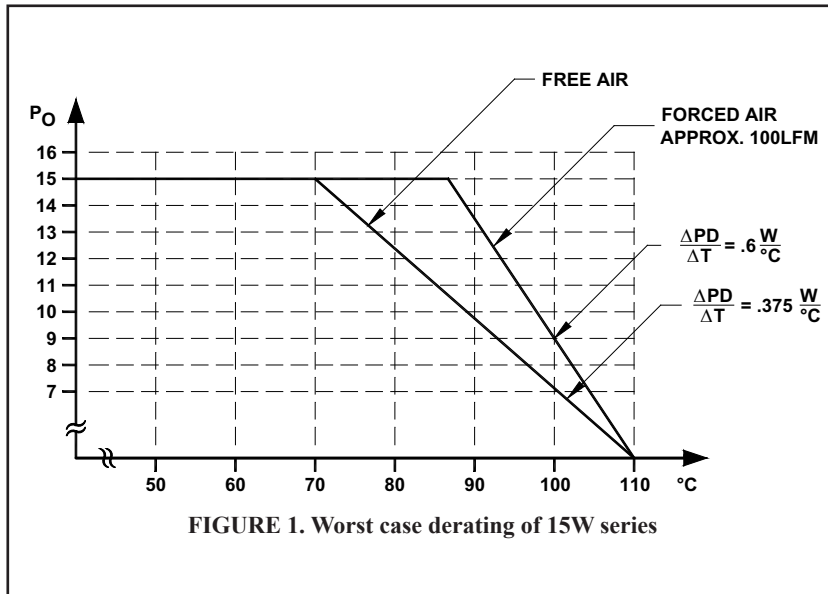

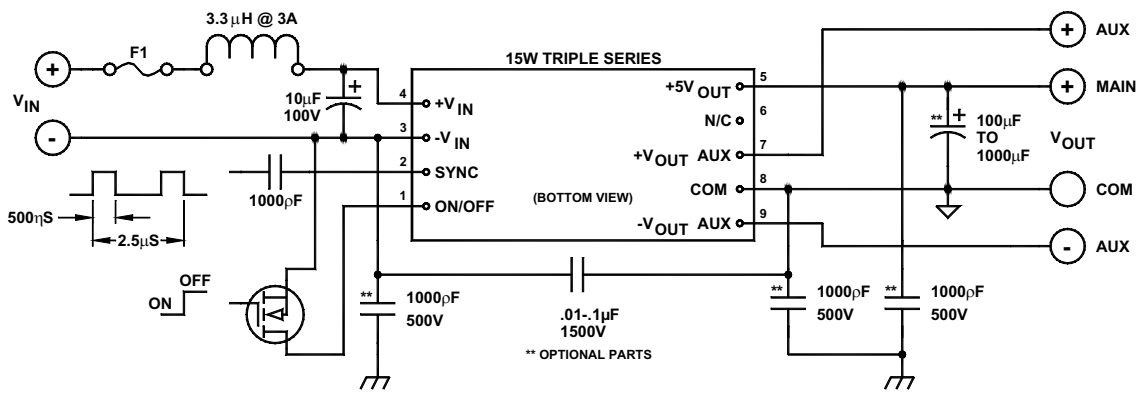

FIGURE 2. Typical connection diagram of a 15W triple converter

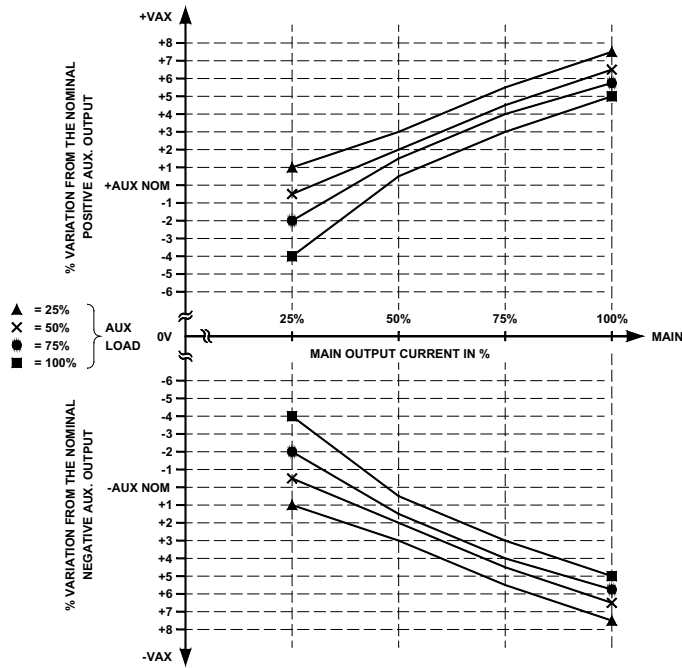

FIGURE 7. Graph of typical load regulation of a triple output.  
Variation in % of  $\pm V_{AUX}$  vs. Main output loading.

**MECHANICAL SPECIFICATIONS**  
in inches [mm]

Pin	Function
	<b>TRIPLE</b>
1	ON/OFF
2	SYNC
3	-V <sub>IN</sub>
4	+V <sub>IN</sub>
5	+V <sub>OUT</sub> MAIN
6	No Pin
7	+V <sub>OUT</sub> AUX
8	GND
9	-V <sub>OUT</sub> AUX

