



# BD21002

## 2W HIGH-VOLTAGE, TRIPLE OUTPUT DC/DC CONVERTER

12V<sub>IN</sub>  
 100V<sub>OUT</sub>@5mA, 300V<sub>OUT</sub>@5mA, 75V<sub>OUT</sub>@5mA

### Key Features

- 3 independent isolated outputs
- Input-to-output isolation
- Output-to-output isolation
- Soft start
- Input LC filter
- Short circuit
- EMI six-sided shielding

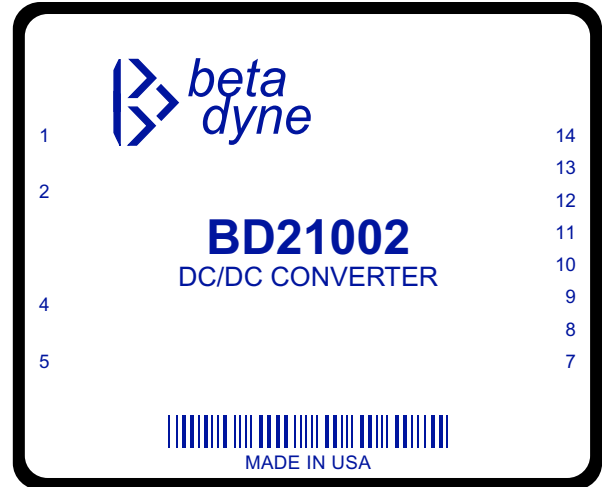

### Functional Description

The BD21002 is a 2W high-voltage, triple output DC/DC converter in a 3.00×2.50×0.75-inch package that accepts 12V<sub>IN</sub> and provides three outputs: 100V<sub>OUT</sub>@5mA, 300V<sub>OUT</sub>@5mA, and 75V<sub>OUT</sub>@5mA with an operating temperature range from -25°C to +60°C. All outputs are isolated from the input and each other. The main output provides ±1% typical line and load regulation, while the two auxiliaries provide ±10%.

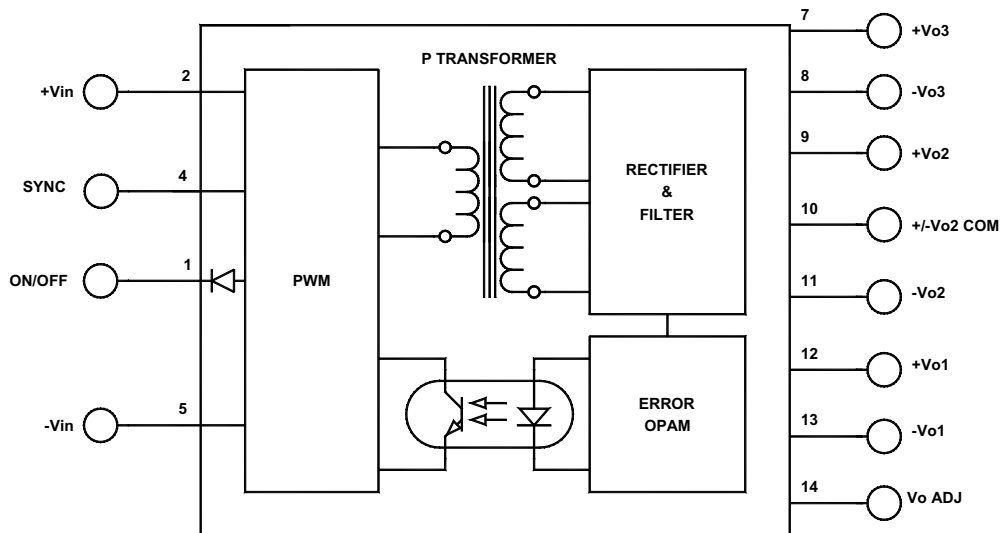

Typical Block Diagram

## Electrical Specifications

### INPUT SPECIFICATIONS

Unless otherwise specified, all parameters are given under typical +25°C with nominal input voltage and under full output load conditions.

PARAMETER	CONDITION / NOTE	MIN	TYP	MAX	UNIT
Input Voltage Range		11	12	13	Vdc
Input Voltage Slew Rate				10	V/μS
No Load Input Current	@12Vdc		80		mA
Full Load Input Current	@12Vdc		320		mA
Input Filter	LC				
Reflected Ripple Current	Measured with 100μF input capacitor, See Figure 1		100		mA <sub>pp</sub>
Reverse Voltage Protection	Parallel Diode		5		A
On/Off	Reference to -V <sub>IN</sub>				
Voltage	Open		10		Vdc
Turn On Delay	Including soft start, See Figure 2		200	250	mS
Startup Input Voltage		11			Vdc

### OUTPUT SPECIFICATIONS

PARAMETER	CONDITION / NOTE	MIN	TYP	MAX	UNIT
Output Voltage			100		Vdc
Output Voltage Accuracy			1		%
Output Current			2	5	mA
Ripple & Noise (20MHz BW)			1	4	% of V <sub>OUTPP</sub>
Line Regulation	Outputs fully loaded		1		%
Load Regulation	10% FL to FL		1		%
Output Voltage			±150		Vdc
Output Voltage Accuracy			5	10	%
Output Current			2	5	mA
Ripple & Noise (20MHz BW)			2	4	% of V <sub>OUTPP</sub>
Line Regulation	Outputs fully loaded		5		%
Load Regulation	10% FL to FL, Main fully loaded		5		%
Output Voltage			75		Vdc
Output Voltage Accuracy			5	10	%
Output Current			2	5	mA
Ripple & Noise (20MHz BW)			2	5	% of V <sub>OUTPP</sub>
Line Regulation	Outputs fully loaded		5	10	%
Load Regulation	10% FL to FL, Main fully loaded		5	10	%
Temperature Coefficient @ FL			±0.02		%/°C
Short Circuit Protection	Continuous, Current Limit				
Short Circuit Restart	Automatic				
Transient Response (to within 1% of V), MAIN	50% FL to 100% FL to 50% FL, See Figure 2		250		μS

### GENERAL SPECIFICATIONS

PARAMETER	CONDITION / NOTE	MIN	TYP	MAX	UNIT
Efficiency			68		%
Isolation Voltage (1 min.)		500	1000		Vdc
Isolation Resistance			10 <sup>9</sup>		Ω
Isolation Capacitance			300		pF
Switching Frequency			125	130	kHz

## ENVIRONMENTAL SPECIFICATIONS

PARAMETER	CONDITION / NOTE	MIN	TYP	MAX	UNIT
Operating Temperature Range (Ambient)		-25		+60	°C
Storage Temperature Range		-60		+125	°C
Derating	See Figure 7				
Thermal Protection, Turn Off <sup>1</sup>	Junction Temperature		145		°C
Thermal Hysteresis			30		°C
Humidity	Up to 95% non-condensing				
Cooling	Free-air convection				
MTBF	per MIL-HNBK-217F (Ground benign, +25°C)		TBD		hours

## PHYSICAL CHARACTERISTICS

PARAMETER	CONDITION / NOTE	MIN	TYP	MAX	UNIT
Dimensions (L×W×H)	3.00×2.50×0.75 in. (76.20×63.50×19.05mm)				
Weight	7.6 oz. (215g)				
Case Material	Coated copper				
Shielding	Six-sided continuous				
Case Connection	IN				

<sup>1</sup> The input power may have to be recycled after thermal turn off.

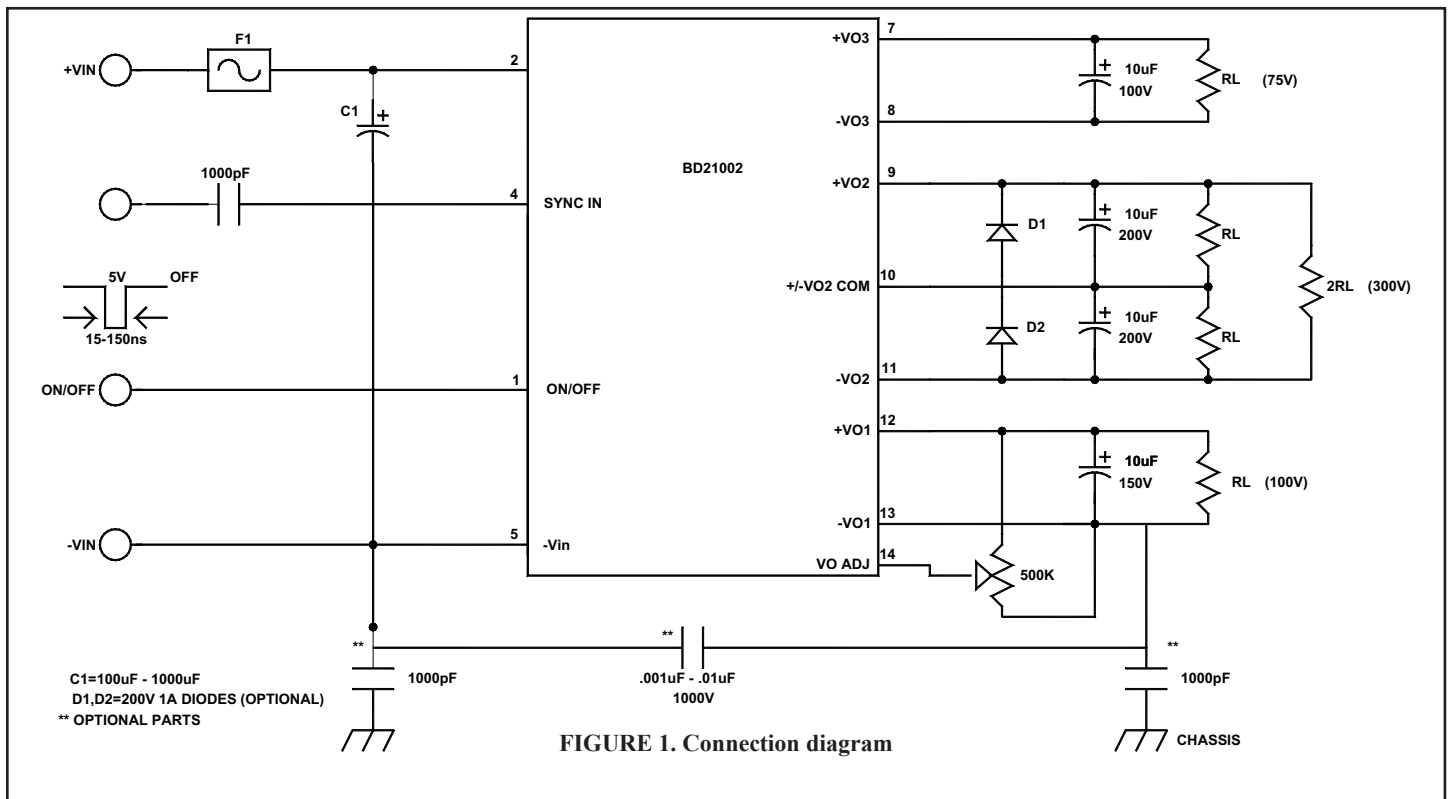

## MECHANICAL SPECIFICATIONS

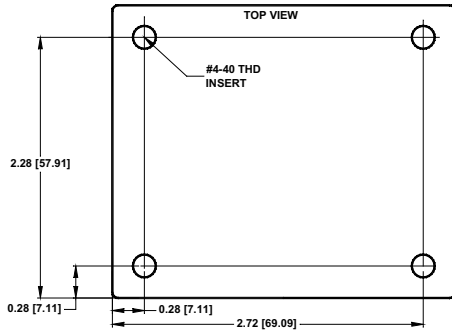

Pin	Function	Pin	Function
1	ON/OFF	7	+V <sub>O3</sub> (+75V)
2	+V <sub>IN</sub>	8	-V <sub>O3</sub> (-75V)
3	No Pin	9	+V <sub>O2</sub> (+150V) *
4	SYNC	10	±V <sub>O2</sub> , COM (±150V)
5	-V <sub>IN</sub>	11	-V <sub>O2</sub> (-150V) *
		12	+V <sub>O1</sub> (+100V)
		13	-V <sub>O1</sub> (-100V)
		14	V <sub>OUT</sub> ADJ

\* For 300V, connect the load between Pin 9 (+150V) and Pin 11 (-150V)

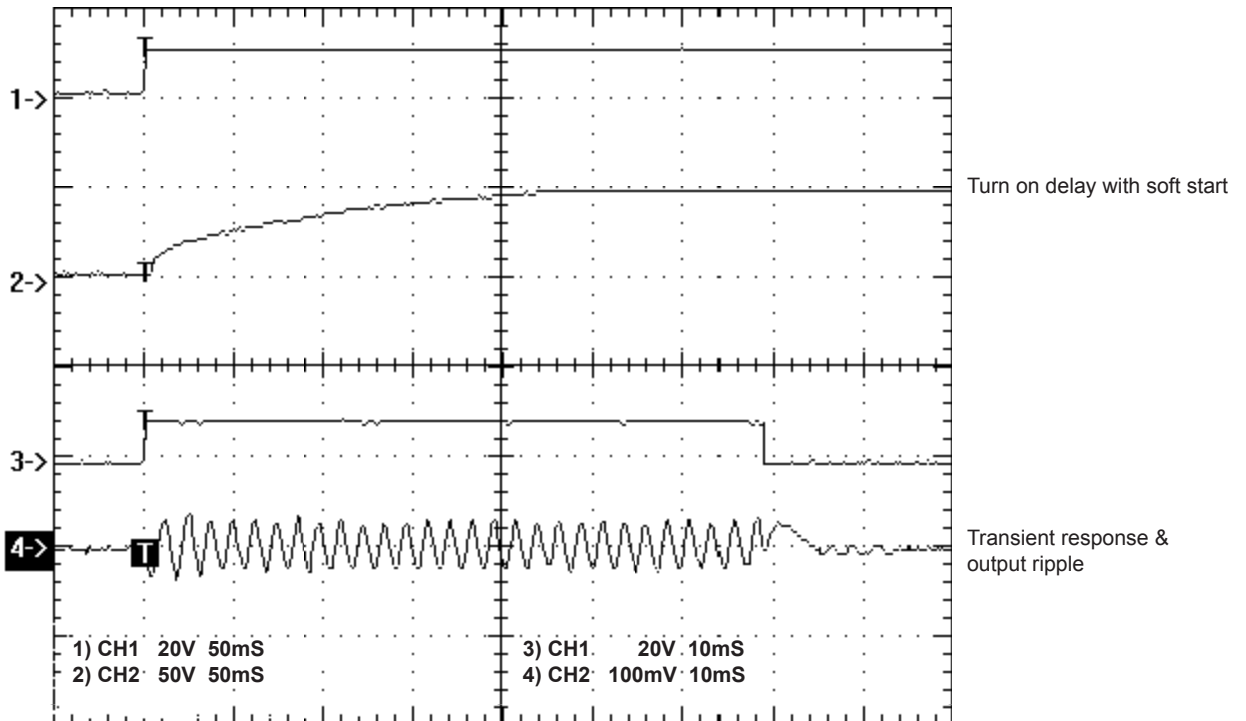
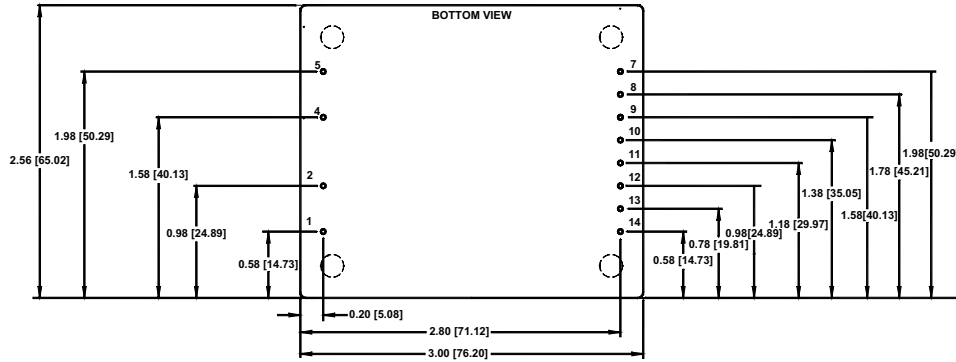
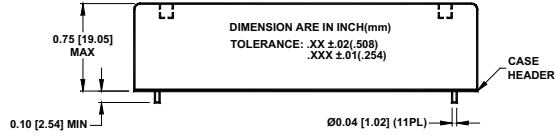

FIGURE 2. Turn on delay and transient response