



BD25006

25W DUAL DC/DC CONVERTER

$36-75V_{IN}$ $\pm 15V_{OUT}$ @ $\pm 830mA$

Key Features

- 25 μ S transient response
- 85% efficiency
- Six-sided shielding
- Soft start
- Dual output
- Short circuit protection
- Adjustable output
- 75 μ A off state current
- Wide input voltage range (2:1)
- Synchronization
- Input over/under voltage protection
- Output over/under voltage protection
- Industry pinout



Functional Description

The BD25006 is a 25W dual output, adjustable DC/DC converter that accepts 36–75V_{IN}, provides $\pm 15V_{OUT}$ @ $\pm 830mA$ maximum and operates from -40° to +70°C. The converter can be synchronized to an external clock frequency of 310KHz or higher.

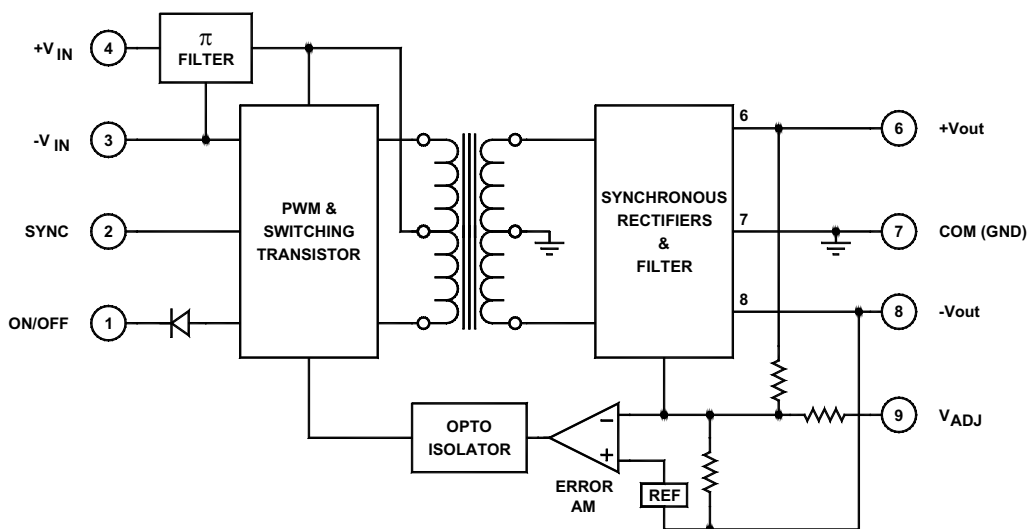

Typical Block Diagram

Electrical Specifications

INPUT SPECIFICATIONS

Unless otherwise specified, all parameters are given under typical +25°C with nominal input voltage and under full output load conditions.

PARAMETER	CONDITION / NOTE	MIN	TYP	MAX	UNIT
Input Voltage Range		36	48	75	Vdc
No Load Input Current			30		mA
Full Load Input Current			610		mA
Sync Frequency		300	330	360	kHz
Input Filter	LC				
Reverse Polarity Input Current Δ	External series-blocking diode			12	A
Input Surge Current (20 μ S Spike)				10	A
Short Circuit Current Limit			150		% I _{IN}
Undervoltage Shutdown			34		Vdc
Off State Current			75		μ A
Remote ON/OFF Control					
Supply ON	Open (Open circuit voltage: 12V Max.)				
Supply OFF		0		0.8	Vdc
Logic Input Reference	-Input				
Logic Compatibility	TTL Open Collector or CMOS Open Drain				
Converter Standby Current			32		mA

OUTPUT SPECIFICATIONS

PARAMETER	CONDITION / NOTE	MIN	TYP	MAX	UNIT
Output Voltage			± 15		Vdc
Output Current			± 830		mA
Output Voltage Accuracy			± 1	± 2	%
Output Voltage Adjustment			± 3	± 5	%
Voltage Balance	Balanced loads		± 1	± 2	%
Minimum Load		10			% of FL
Ripple & Noise	(See App. Note DC-003)		1	2	%V _{PP} of V _{OUT}
Line Regulation	Minimum V _{IN} to maximum V _{IN}		± 1	± 2	%
Load Regulation	Balanced loads		± 1	± 2	%
Temperature Coefficient @ FL			0.02		%/°C
Transient Response Time	50% FL to FL to 50% FL		25		μ S
Short Circuit Protection	All outputs, by input current limiting				
Output Short Circuit Duration	Continuous				

GENERAL SPECIFICATIONS

PARAMETER	CONDITION / NOTE	MIN	TYP	MAX	UNIT
Efficiency			85		%
Isolation Voltage (1 min.)			1500		Vdc
Isolation Resistance			10 ⁹		Ω
Isolation Capacitance			80		pF
Switching Frequency			160		kHz

PHYSICAL CHARACTERISTICS

PARAMETER	CONDITION / NOTE	MIN	TYP	MAX	UNIT
Dimensions (L×W×H)	2.00×2.00×0.395 in. (50.80×50.80×10.03mm)				
Weight	2 oz. (58g)				
Case Material	Coated metal				
Shielding Connection	-Input (Pin 3)				

ENVIRONMENTAL SPECIFICATIONS

PARAMETER	CONDITION / NOTE	MIN	TYP	MAX	UNIT
Operating Temperature, Industrial (Ambient)*	See Figure 2	-40		+70	°C
Storage Temperature Range		-55		+125	°C
Thermal Resistance			8		°C/W _{DISS}
Maximum Operating Case Temperature				105	°C
Thermal Turn Off, Case Temperature		95	100	115	°C
Thermal Hysteresis		5	10		°C
Derating	See Figure 2				
Humidity	Up to 95% non-condensing				
Cooling	Free-air convection				
EMI/RFI	Six-sided continuous shielded metal case				
MTBF	per MIL-HNBK-217F (Ground benign, +25°C)		718,000		hours

* See footnotes 2, 3, 4 and 5

¹ ⚠ WARNING - Usage of input fuse with adequate ratings is essential to avoid possible hazard and damage of the unit. A suppressor diode with adequate ratings is intended to be connected in series to the supply for reverse polarity protection.

² Contact factory for -55° to +85°C operating temperature range.

³ The maximum input current at any given input range measured at minimum input voltage is given as $1.6 \cdot I_{NOMINAL}$. Nominal input current is the typical value measured at the input of the converter under full-load room temperature and nominal input voltage (12, 24 and 48Vin).

⁴ Adequate insulation is to be provided to the converters at the end usage as per applicable requirements.

⁵ Temperature rise on the case of the converters is to be considered during the end usage as per applicable requirements.

EXTERNAL SYNCHRONIZATION

The converter can be synchronized to an external clock by driving the SYNC pin (pin 2) directly or with an open collector-open drain (1 TTL load). The driving signal frequency must be $330\text{kHz} \pm 5\%$ (20% low, 80% high duty cycle). The PWM used in the converter offers bidirectional SYNC ports, which allow multiple unit synchronization by connecting all SYNC pins together. In the absence of an

external clock, the faster unit takes control of the SYNC bus and the rest of the units follow. When the external clock is AC-coupled to the SYNC pin of the converter through a ceramic capacitor, connect a signal Schotky diode with the cathode connected to the SYNC pin and the anode to $-V_{IN}$ (See Figure 1).

EXTERNAL TRIMMING OF OUTPUT VOLTAGES

To trim the output voltage DOWN, connect a 5% $\frac{1}{4}W$ resistor between the + (positive) output and trim pins of the converter. To trim the output voltage UP, connect a 5% $\frac{1}{4}W$ resistor between the - (negative) output and trim pin of the converter. For UP/DOWN trimming capability, connect a 10kΩ potentiometer between the + and - pins, with the wiper arm connected to the trim pin. The trim resistors/potentiometer can be connected at the converter output pins or the load. However, if connected at the load, the resistance

of the runs becomes part of the feedback network, improving load regulation. If the load is some distance from the converter, the use of #20 gauge wire is recommended to avoid excessive voltage drop due to the resistance of the circuit paths.

See our application notes:

DC-001: Testing Transient Response in DC/DC Converters

DC-004: Thermal Consideration for DC/DC Converters

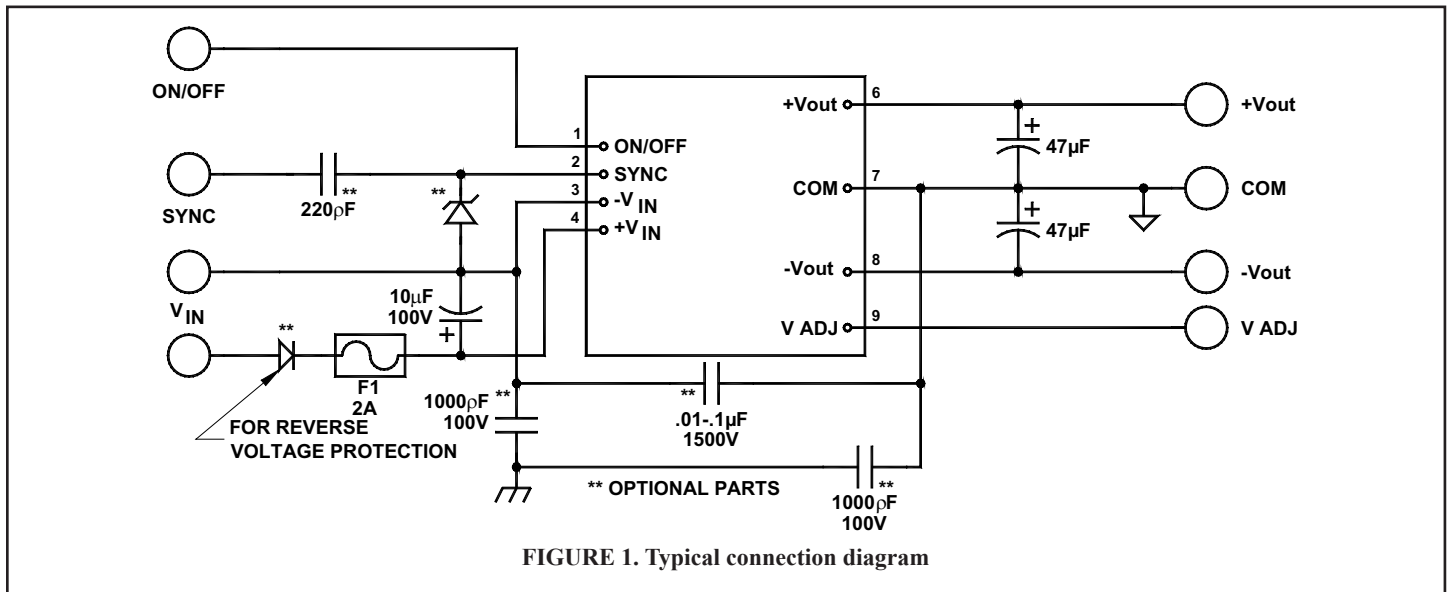

FIGURE 1. Typical connection diagram

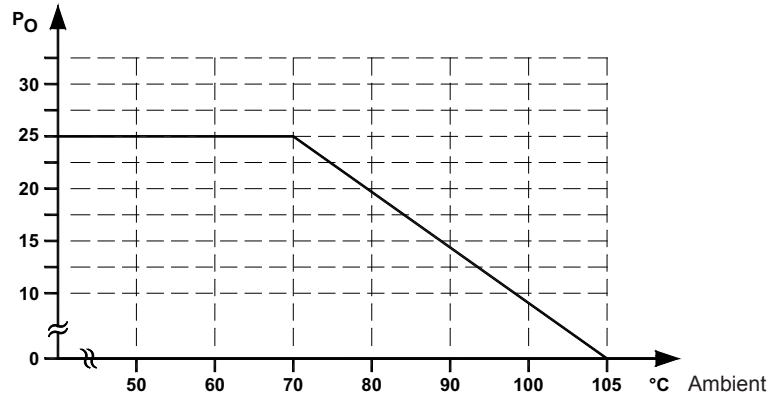

FIGURE 2. Typical derating curve

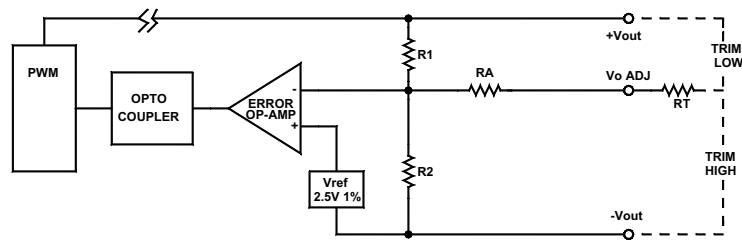

FIGURE 3. Output control circuit

To trim V_o higher to V_o' , where V_o is the actual measured value:

$$RT = \frac{R1 \cdot V_{REF}}{V_o' - V_o}$$

To trim V_o lower to V_o'' , where V_o is the actual measured value:

$$RT = \left[\left(\frac{R_1^2 \cdot V_{REF}}{R_2(V_o - V_o'')} - R1 \right) \cdot RA \right]$$

Resistor	Value (K)
R1	27.4
R2	2.49
RA	24

MECHANICAL SPECIFICATIONS

in inches [mm]

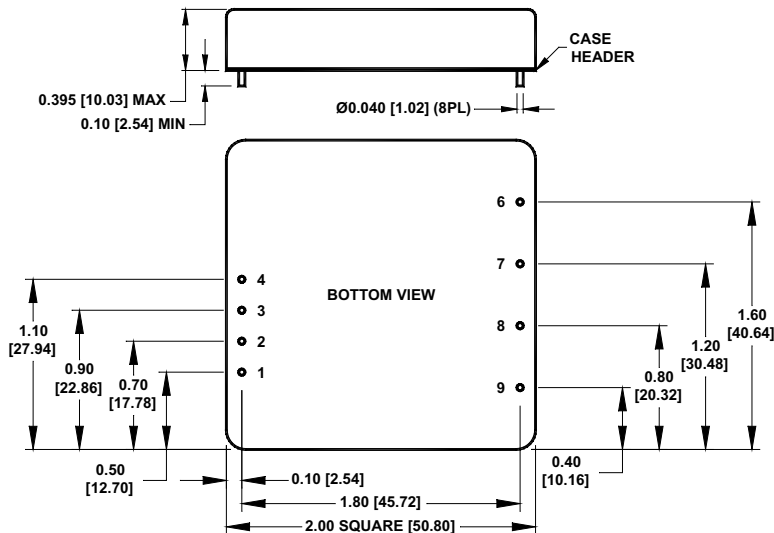

Pin	Function
	DUAL
1	ON/OFF
2	SYNC
3	$-V_{IN}$
4	$+V_{IN}$
5	No Pin
6	$+V_{OUT}$
7	GND
8	$-V_{OUT}$
9	V_{OUT_ADJ}