



BD5001

4W HIGH-VOLTAGE DC/DC CONVERTER
24-PIN DIP

Key Features

- 82% efficiency
- 1500Vdc isolation
- Short circuit and thermal protection
- 60Vdc to 130Vdc input voltage range
- Metal case
- Six-sided shielding
- 2mA off state current
- Industry standard pinout



Functional Description

The BD5001 is a 4W High-Voltage, Isolated DC/DC Converter that accepts $60V_{IN}$ to $130V_{IN}$ and provides $12V_{OUT}$ @ $300mA$.

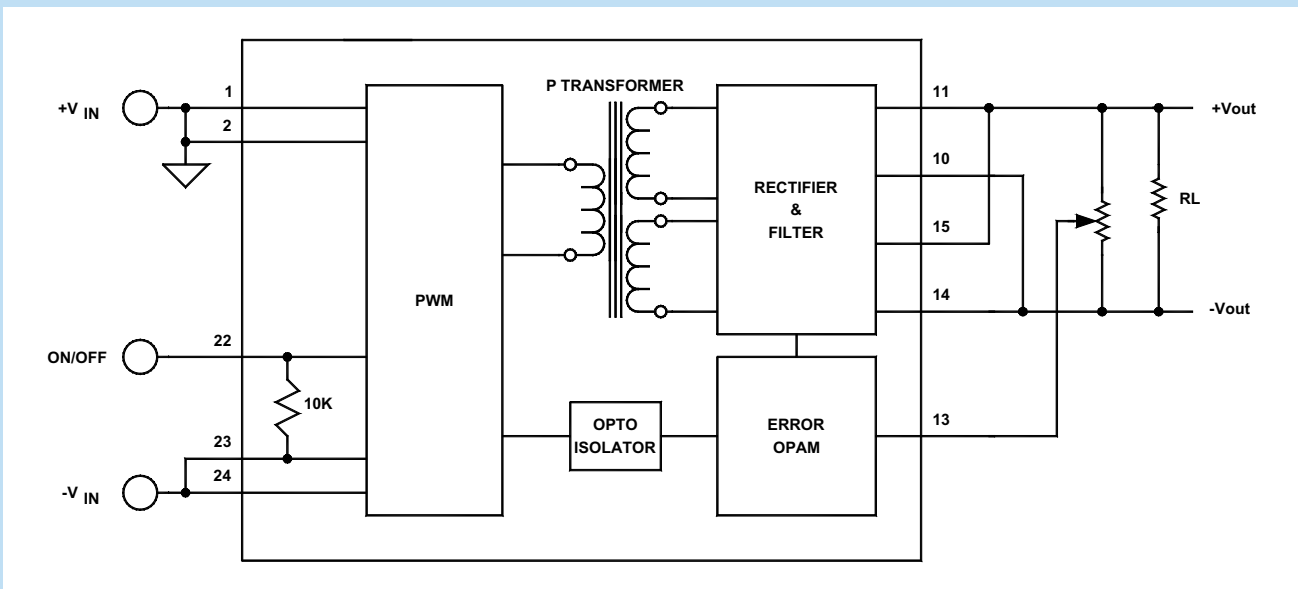

Typical Block Diagram

Electrical Specifications
ABSOLUTE MAXIMUM RATINGS

Unless otherwise specified, all parameters are given under typical +25°C with nominal input voltage and under full output load conditions.

PARAMETER	CONDITION / NOTE	MIN	TYP	MAX	UNIT
Output Short Circuit Duration	Continuous				
Internal Power Dissipation				1.2	W

INPUT SPECIFICATIONS

PARAMETER	CONDITION / NOTE	MIN	TYP	MAX	UNIT
Input Voltage Range		60	95	130	Vdc
No Load Input Current			4		mA
Full Load Input Current			46		mA
Input Filter	0.47μF for 120V _{IN}				μF
Reverse Polarity	External series-blocking diode				
Reflected Ripple	I _O = FL, C _{IN} = 10μF, See Figure 4				
Input Surge Current (20μS Spike)				10	A
Short Circuit Current Limit	See Short Circuit Protection		150		% I _{IN}
Off State Current			2		mA
Remote ON/OFF Control					
Supply ON	Pin 22 Open (Open circuit voltage: 0V)				
Supply OFF	Pin 22	5	10	15	Vdc
Logic Input Reference	-Input for ON/OFF				

OUTPUT SPECIFICATIONS

PARAMETER	CONDITION / NOTE	MIN	TYP	MAX	UNIT
Output Voltage			12		Vdc
Output Voltage Accuracy			±1	±2	%
Ripple & Noise	With specified minimum output capacities		1	2	%V _{PP} of V _{OUT}
Output Current			300		mA
Line Regulation, Single			±1	±2	%
Load Regulation, Single			±1	±2	%
Temperature Coefficient @ FL			0.02		%/°C
Transient Response Time	50% FL to FL to 50% FL, C _O =3.3μF, See Figure 3		1	2	mS
Short Circuit Protection ¹	By input current limiting				
Output Adjust Range	See Figure 2;	±5		±10	%

GENERAL SPECIFICATIONS

PARAMETER	CONDITION / NOTE	MIN	TYP	MAX	UNIT
Efficiency			82		%
Isolation Voltage (1 min.), Input to Output			1500		Vdc
Isolation Voltage (1 min.), Output to Output			500		Vdc
Isolation Resistance			10 ⁹		Ω
Isolation Capacitance			1000		pF
Switching Frequency			125		kHz
Turn On Delay	See Figure 3		5	10	mS
Soft Start Time	See Figure 3		20		mS

PHYSICAL CHARACTERISTICS

PARAMETER	CONDITION / NOTE	MIN	TYP	MAX	UNIT
Dimensions (L×W×H)	1.25×0.8×0.4 in. (31.75×20.32×10.16mm)				
Weight	0.56 oz. (15.8g)				
Case Material	Coated metal				
Shielding	Six-sided continuous				
Case Connection					

ENVIRONMENTAL SPECIFICATIONS

PARAMETER	CONDITION / NOTE	MIN	TYP	MAX	UNIT
Operating Temperature Range (Ambient)	See Figure 1	-40		+70	°C
Storage Temperature Range		-60		+105	°C
Thermal Shutdown	Case temperature (Input power must be recycled)	96	100	104	°C
Thermal Resistance	Maximum case temperature is 36°C above ambient		36		°C/W
Derating	See Figure 1				
Humidity	Up to 95% non-condensing				
Cooling	Free-air convection				
MTBF	per MIL-HNBK-217F (Ground benign, +25°C)		1.3x10 ⁶		hours

¹ The maximum input current at any given input range measured at minimum input voltage is given as 1.6*^{NOMINAL}. Nominal input current is the typical value measured at the input of the converter under full-load room temperature and nominal input voltage (24, 48 and 120Vdc).

² Input power may need to be recycled if the input overcurrent threshold is exceeded after a hard output short circuit.

³ With a 10µH input inductor and 10µF input capacitor.

MECHANICAL SPECIFICATIONS

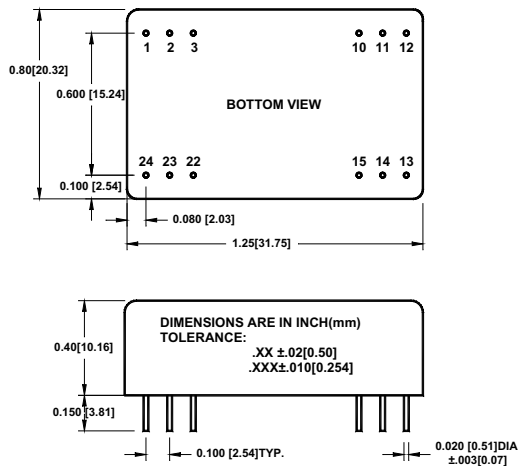

Pin	Function
SINGLE	
1	+V _{IN}
2	+V _{IN}
3	CASE
10	-V _{O1} (CONNECT TO PIN 14)
11	+V _{O1} (CONNECT TO PIN 15)
12	No Pin
13	V _{OUT} ADJ
14	-V _{O2} (CONNECT TO PIN 10)
15	+V _{O2} (CONNECT TO PIN 11)
22	ON/OFF
23	-V _{IN}
24	-V _{IN}

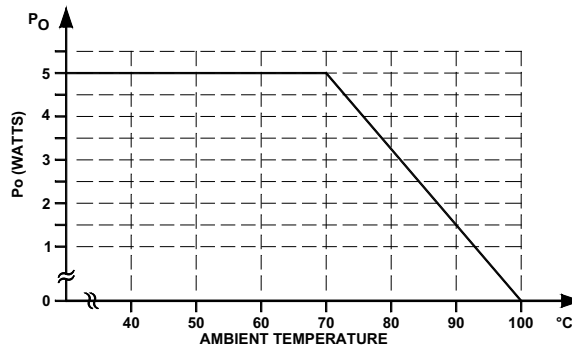

FIGURE 1. Typical derating curve

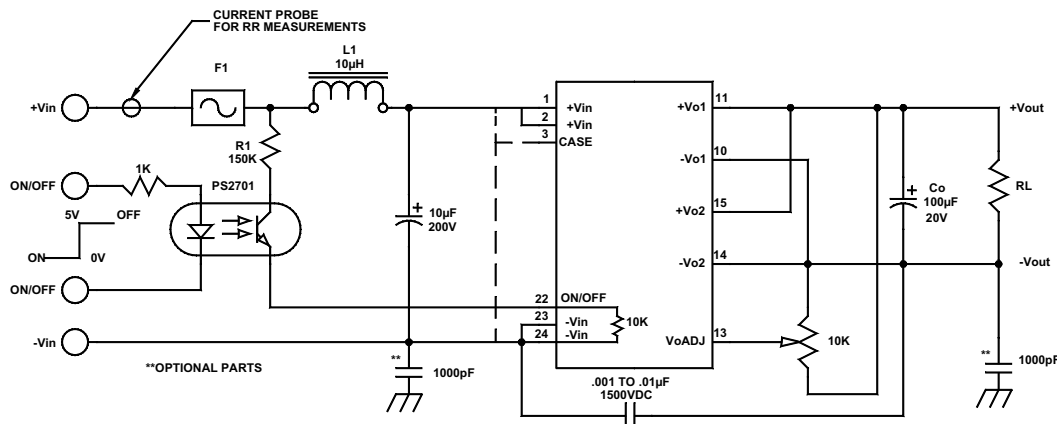

FIGURE 2. Typical connection diagram

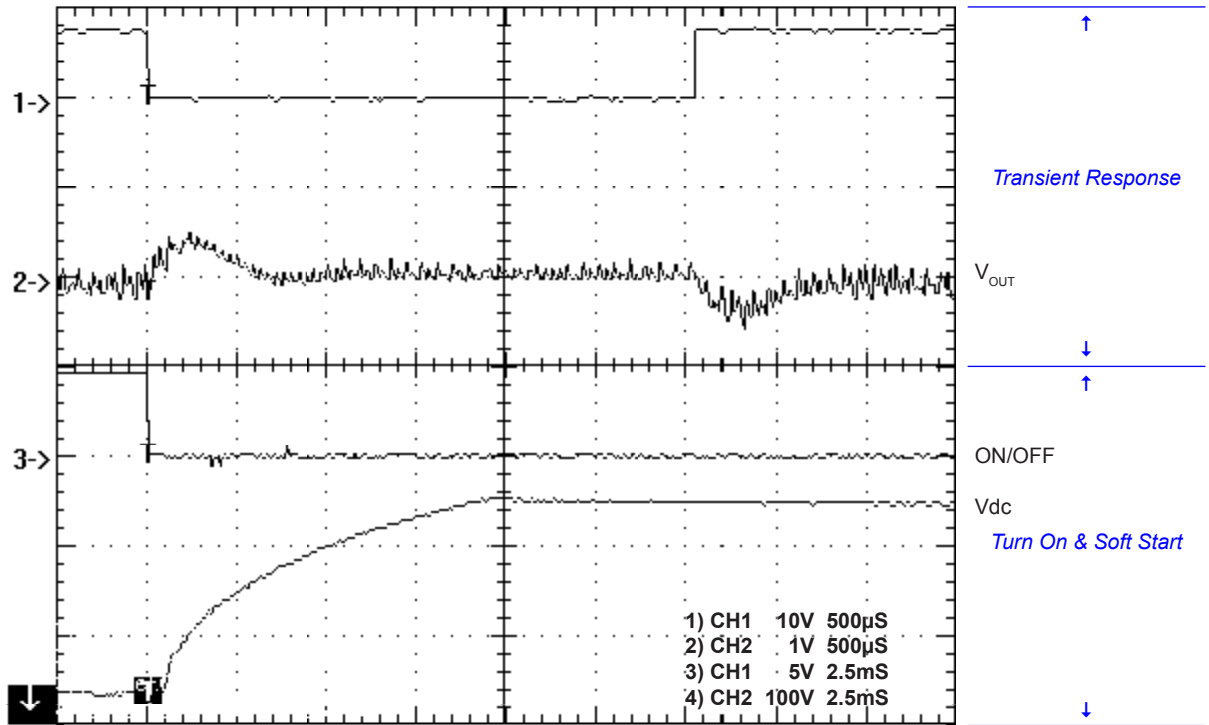

FIGURE 3. Transient Response and Soft Start
 ($R_L=10k$, $C_o=3.3\mu F@400V$)

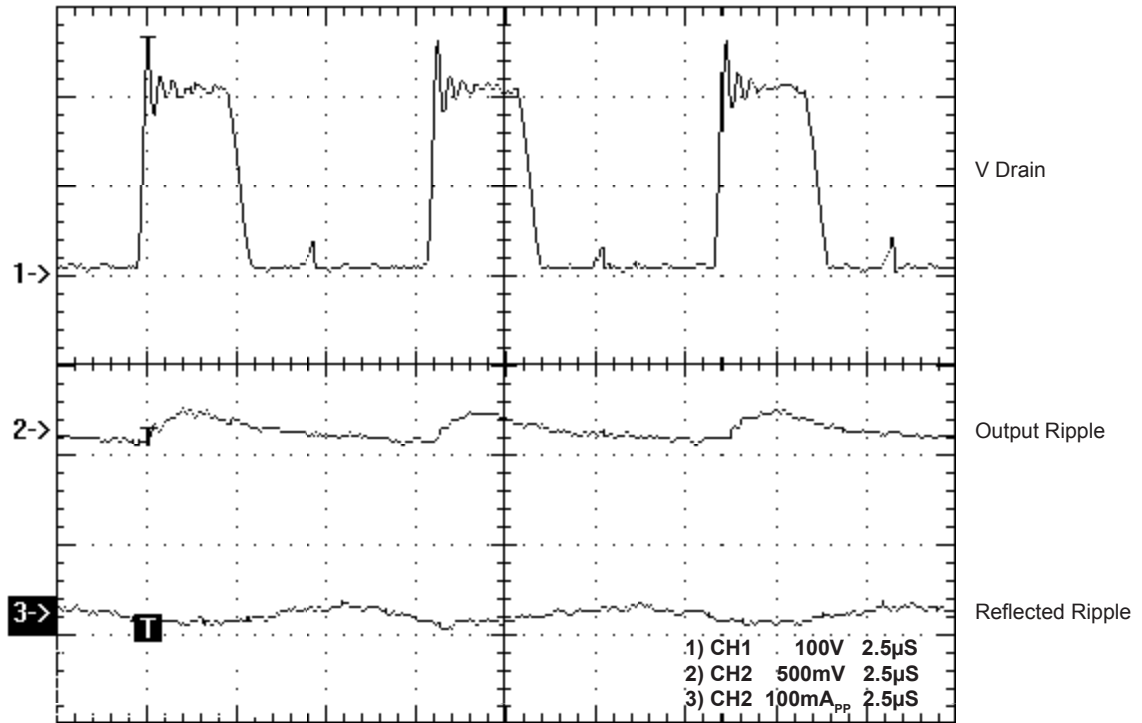

FIGURE 4. Typical waveforms
 ($R_L=20k$, $C_o=3.3\mu F@400V$)