



# EA60012

## 50W SINGLE DC/DC CONVERTER

19-40V<sub>IN</sub>, 12V<sub>OUT</sub>@4.2A  
 US Patents 6,262,901 B1 & 6,473,317 B1

### Key Features

- 92% efficiency
- Output overvoltage protection (OVP)
- Wide input voltage range (2:1)
- Six-sided shielding
- Soft start
- 1500Vdc input-to-output isolation
- Short circuit and thermal protection
- Adjustable output
- 300µA off state current
- Output synchronous rectification
- Input undervoltage protection



Label shown for illustration only.  
 Label is located on side or bottom of unit.

### Functional Description

The EA60012 is an isolated 50W single output DC/DC converter that accepts 19V<sub>IN</sub> to 40V<sub>IN</sub> and provides 12V<sub>OUT</sub>@4.2A. Push-pull topology and output synchronous rectification allow for continuous operation even at low input voltages with maximum efficiency. Six-sided shielding with external synchronization minimizes EMI and RFI. Protection features allow the converters to operate in harsh environments.

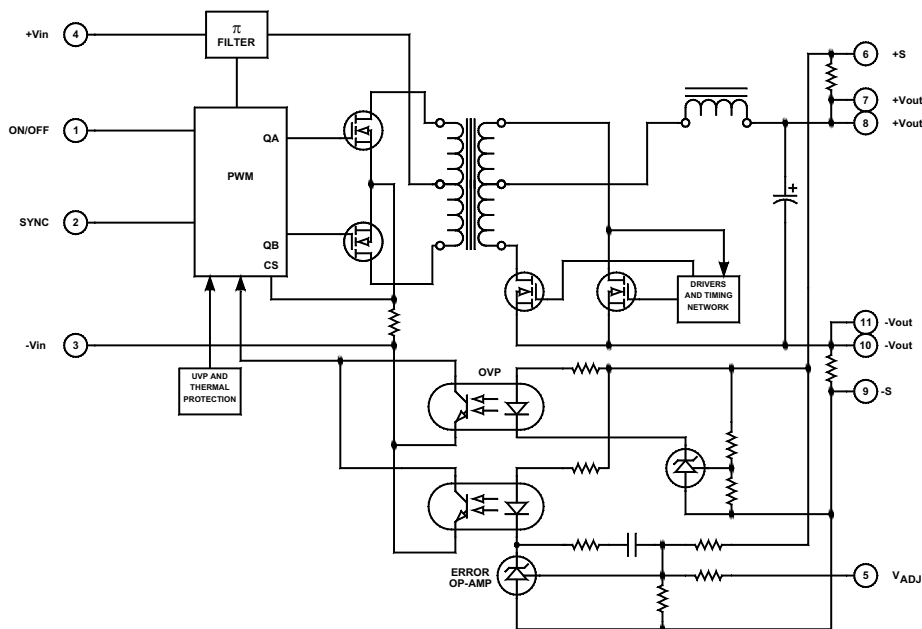

Typical Block Diagram

## Electrical Specifications

### INPUT SPECIFICATIONS

Unless otherwise specified, all parameters are given under typical +25°C with nominal input voltage and under full output load conditions.

PARAMETER	CONDITION / NOTE	MIN	TYP	MAX	UNIT
Input Voltage Range		14	24	34	Vdc
Input Filter	LC				
Reverse Polarity Input Current				12	A
Input Surge Current (20µS Spike)				10	A
No Load Input Current			50		mA
Full Load Input Current			2265		mA
Short Circuit Current Limit			150		% I <sub>IN</sub>
Undervoltage Shutdown		12			Vdc
Off State Current			300		µA
Remote ON/OFF Control					
Converter ON	Open (Open circuit voltage at Pin 1: 10V Max.)				
Converter OFF		-0.6	0	0.2	Vdc
Logic Input Reference	-Input				
Logic Compatibility	TTL Open Collector or CMOS Open Drain				
Sync Input	TTL	2.5		5	Vdc
Sync Input Frequency Range		190	200	210	kHz
Sync Input Minimum Pulse Width	See Figure 4	200			nS

### OUTPUT SPECIFICATIONS

PARAMETER	CONDITION / NOTE	MIN	TYP	MAX	UNIT
Output Voltage			12		Vdc
Output Current			4.2		A
Output Voltage Accuracy			±1	±1.5	%
Output Voltage Adjustment			3	±5	%
Minimum Load		10			% of FL
Ripple & Noise			1	2	% <sub>PP</sub>
Line Regulation	Minimum V <sub>IN</sub> to maximum V <sub>IN</sub>		±1	±2	%
Load Regulation	NL to FL		±1	±2	%
Temperature Coefficient @ FL			0.02		%/°C
Transient Response Time (to within 1% of V <sub>OUT</sub> )	50% FL to FL to 50% FL, See Figure 3		50		µS
Short Circuit Protection	By input current limiting				
Output Short Circuit Duration	Continuous				

### GENERAL SPECIFICATIONS

PARAMETER	CONDITION / NOTE	MIN	TYP	MAX	UNIT
Efficiency			92		%
Isolation Voltage (1 min.)			1500		Vdc
Isolation Resistance			10 <sup>9</sup>		Ω
Isolation Capacitance			80		pF
Switching Frequency		95	100		kHz

### ENVIRONMENTAL SPECIFICATIONS

PARAMETER	CONDITION / NOTE	MIN	TYP	MAX	UNIT
Operating Temperature, Industrial (Ambient)	See Figure 2	-40		+71	°C
Storage Temperature Range		-55		+125	°C
Thermal Resistance			3		°C/W <sub>DISS</sub>
Maximum Operating Case Temperature			85		°C
Thermal Turn Off, Case Temperature		80	90	100	°C
Thermal Hysteresis			10		°C
Derating	See Figure 2				
Humidity	Up to 95% non-condensing				
Cooling	Free-air convection				
EMI/RFI	Six-sided continuous shielded metal case				
MTBF	per MIL-HNBK-217F (Ground benign, +25°C)		625 000		hours

**PHYSICAL CHARACTERISTICS**

PARAMETER	CONDITION / NOTE	MIN	TYP	MAX	UNIT
Dimensions (L×W×H)	2.00×2.00×0.50 in. (50.80×50.80×12.70mm)				
Weight	2.78 oz. (79g)				
Case Material	Coated metal				
Shielding Connection	-V <sub>IN</sub> (Pin 3)				

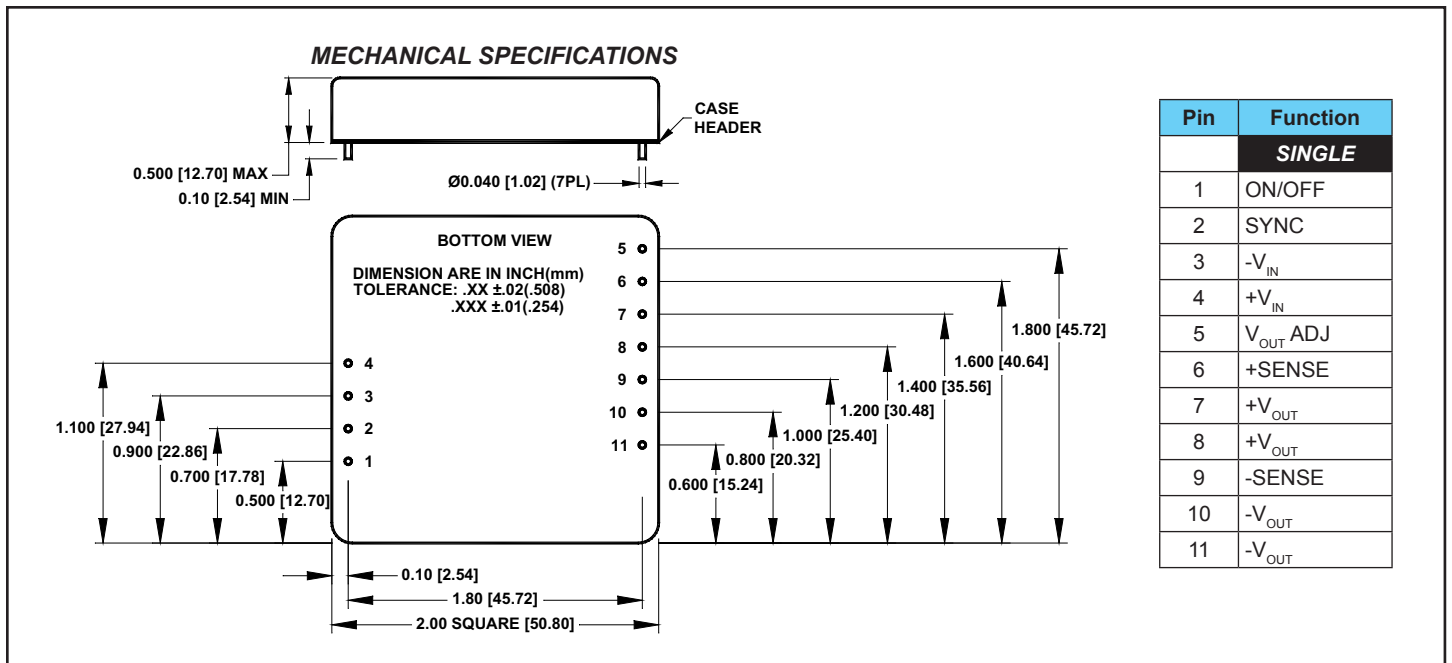
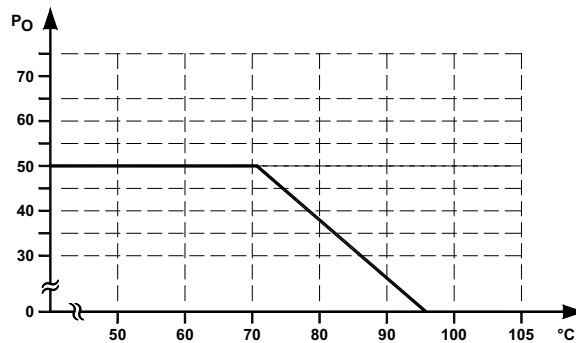
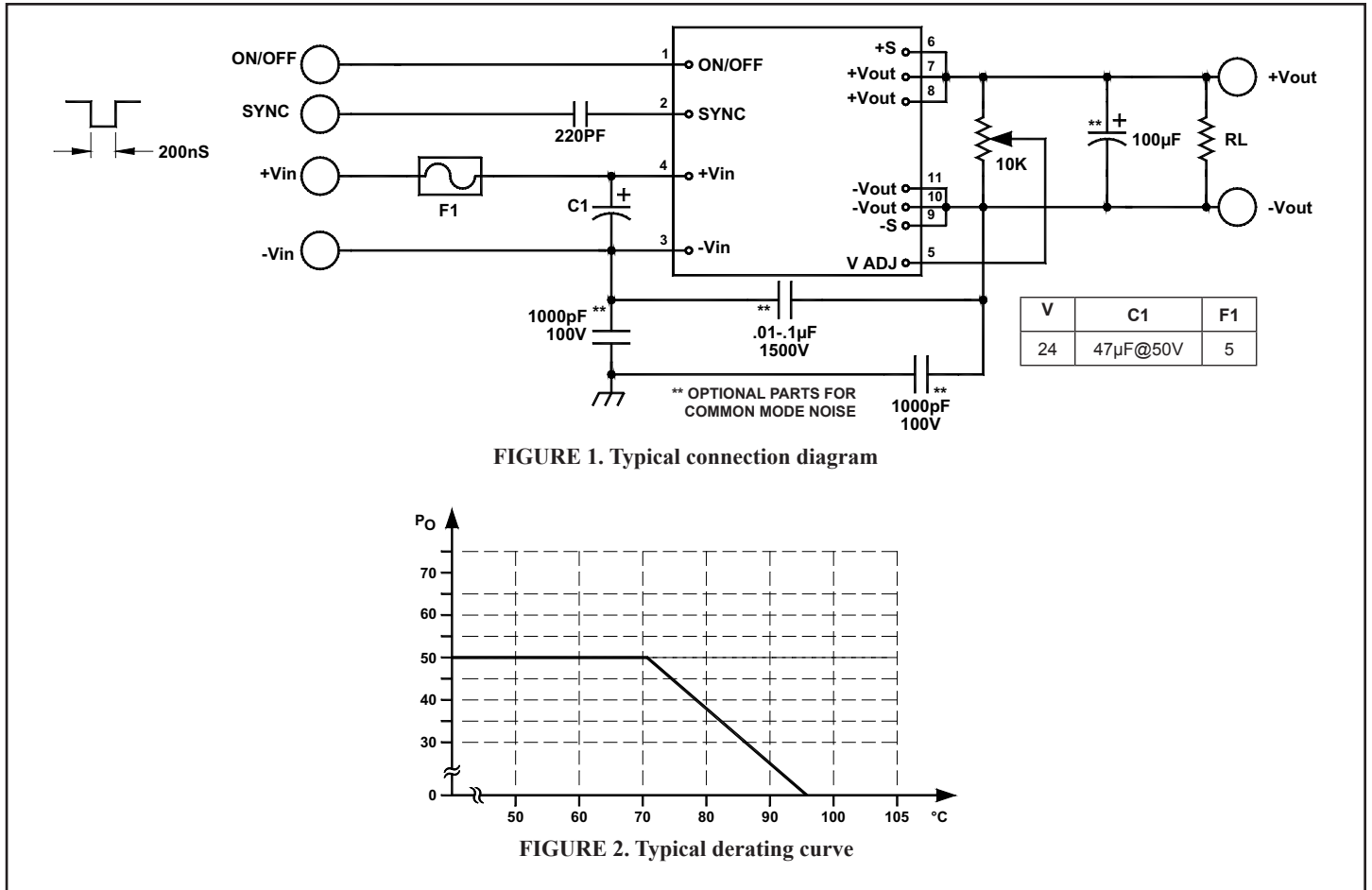

### EXTERNAL SYNCHRONIZATION

The converter can be synchronized to an external clock by driving the SYNC pin (pin 2) directly. The driving signal frequency must be  $\geq 200\text{kHz}$ . When the external clock is AC-coupled to the SYNC pin of the converter through a ceramic capacitor, connect a signal Schotky diode with the cathode connected to the SYNC pin and the

anode to  $-V_{IN}$  (See Figure 4). AC coupling reduces the power required for driving multiple converters and allows for continuous operation of the other synchronized converters in case the driving signal is missing or a short circuit develops at one of the sync inputs.

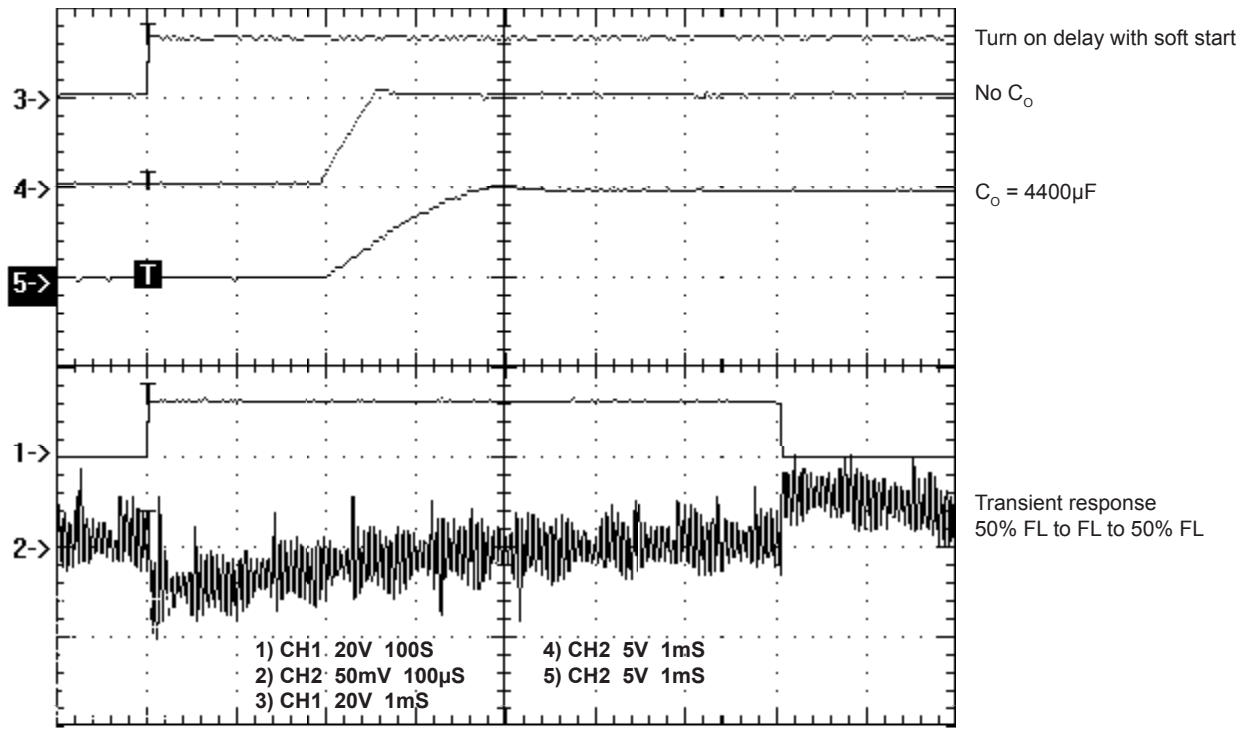

FIGURE 3. Turn on delay with soft start and transient response

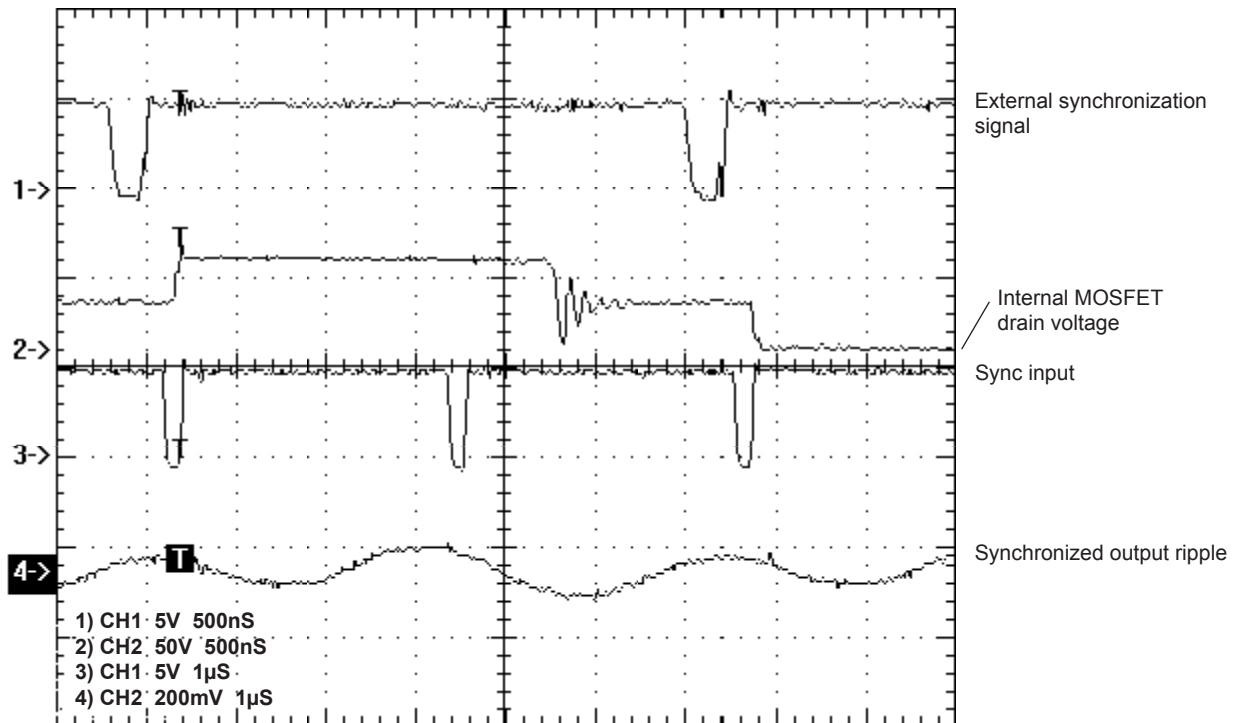

FIGURE 4. Synchronization waveforms