

PRELIMINARY

EBL30002

30W Low-Noise DC/DC CONVERTER

18-36Vin, 5Vout



Key Features

- Efficiency up to 86%
- 20 mV output noise
- Six-sided shielding
- Output synchronous rectification
- Input-to-output isolation
- Soft start
- External synchronization
- Short circuit protection
- Thermal protection
- Industry standard pinout



Beta Dyne is protected under various patents, including but not limited to U.S. Patent numbers: 5,777,519; 6,188,276; 6,262,901; 6,452,818; 6,473,3171.

Functional Description

The EBL30002 is a 30W Low Noise isolated converter, with an output of 5 Vdc and 2:1 input voltage range from 18V to 36V. Output synchronous rectification followed by a very low dropout linear regulator makes possible to achieve up to 86% efficiency and less than 20mV output noise. Standard features include input undervoltage protection, external synchronization and thermal protection. The converter is packaged in a 1 x 2 x .45" metal case with six-sided shielding.

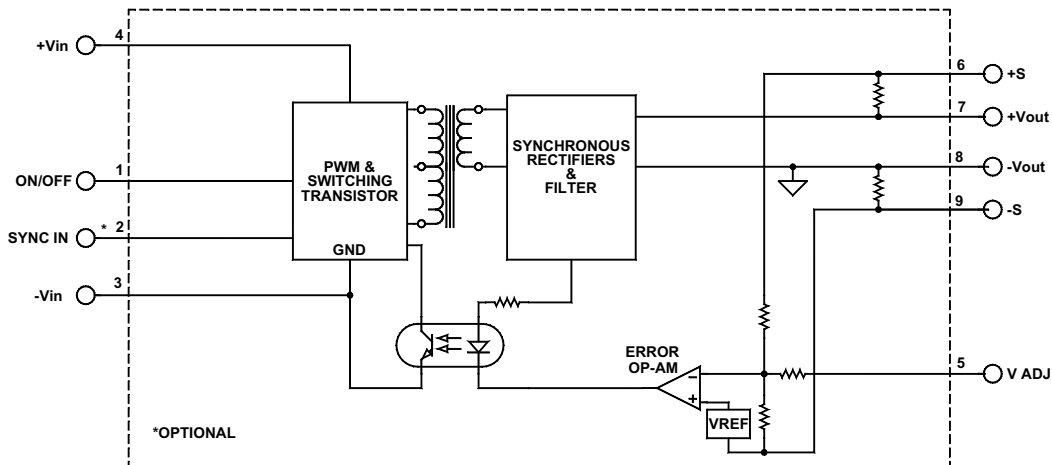

Typical Block Diagram

Unless otherwise specified, all parameters are given under typical ambient temperature of +25°C with an airflow rate = 400LFM. With the given power derating, the operating range is -40°C to +125°C. Specifications subject to change without notice.

Electrical Specifications

INPUT SPECIFICATIONS

PARAMETER	CONDITION / NOTE	MIN	TYP	MAX	UNIT
Input Voltage Range		18	24	36	Vdc
Input Startup Voltage				17	Vdc
Undervoltage Shutdown		16			Vdc
Input Filter	LC				
No Load Input Current			70.1		mA
Full Load Input Current			1450		A
Input Surge Current (20µS Spike)				10	A
Short Circuit Current Limit	120% Of I _{IN} @ Full Load				
Off State Current			150		µA
Remote ON/OFF Control					
Supply ON	Pin 3 Open (Open circuit voltage: 10V Max.)				
Supply OFF		0		0.6	Vdc
Logic Input Reference	To -V _{IN}				
Logic Compatibility	TTL Open Collector or CMOS Open Drain				

OUTPUT SPECIFICATIONS

PARAMETER	CONDITION / NOTE	MIN	TYP	MAX	UNIT
Voltage			5		Vdc
Output Voltage Accuracy			1		%
Output Current			6		A
Maximum Output Capacitance	V _{IN} =Nominal Input, V _{OUT} =Full Output Load		15,400		µF
Output Voltage Adjustment	See Figure 10		±5	±10	%
Ripple & Noise	For further reduction see figure 5		30		mV
Line Regulation	Minimum V _{IN} to maximum V _{IN}		±0.04	±0.1	%
Load Regulation	NL to FL		±0.05	±0.1	%
Temperature Coefficient @ FL			1	2	%/°C
Transient Response Time	50% FL to FL to 50% FL, See Figure 7	100			µS
Short Circuit Protection	By input current limiting				
Turn On Delay with Soft Start	See Figure 4		30	40	mS
Output Overvoltage Protection	None				

GENERAL SPECIFICATIONS

PARAMETER	CONDITION / NOTE	MIN	TYP	MAX	UNIT
Efficiency (at full power)			86		%
Isolation Voltage (1 min.), Input to Output			1500		Vdc
Isolation Resistance			10 ⁹		Ω
Isolation Capacitance			300		pF
Switching Frequency (FC)		202	210		kHz
External Sync Frequency (Fe)		210	220	220	kHz

ENVIRONMENTAL SPECIFICATIONS

PARAMETER	CONDITION / NOTE	MIN	TYP	MAX	UNIT
Operating Temperature Range (Ambient)	Industrial, See Note 2	-40		+71	°C
Storage Temperature Range		-55		+125	°C
Maximum Operating Case Temperature ¹				110	°C
Derating	See Figure 4				
Cooling	See Figure 4				
MTBF	per MIL-HNBK-217F (Ground benign, +25°C)		1.1×10 ⁶		hours
Shielding Connection	- V _{IN} for 24 V _{IN}				

PHYSICAL CHARACTERISTICS

PARAMETER	CONDITION / NOTE	MIN	TYP	MAX	UNIT
Dimensions (L×W×H)	2.00×1.00×0.450 in. (50.80×25.40×11.43mm)				
Weight	1.3 oz. (37g)				

- ¹ When converter enters thermal protection on mode , its duty cycle is reduced momentarily and will resume after its internal temperature (pwm) drops down a few degrees (°C).The converter's output behaves similar to hiccup short circuit mode.
- ² Contact factory for -55° to +85°C operating temperature range.
- ³ The maximum input current at any given input range measured at minimum input voltage is given as $1.6 \cdot I_{NOMINAL}$. Nominal input current is the typical value measured at the input of the converter under full-load room temperature and nominal input voltage 24V.
- ⁴ Adequate insulation is to be provided to the converters at the end usage as per applicable requirements.
- ⁵ Temperature rise on the case of the converters is to be considered during the end usage as per applicable requirements.
- ⁶ For reflected input ripple measurements ,with $C_{in}=100\mu f$ and $L_{in}=2.2\mu H$ on the input of the converters.

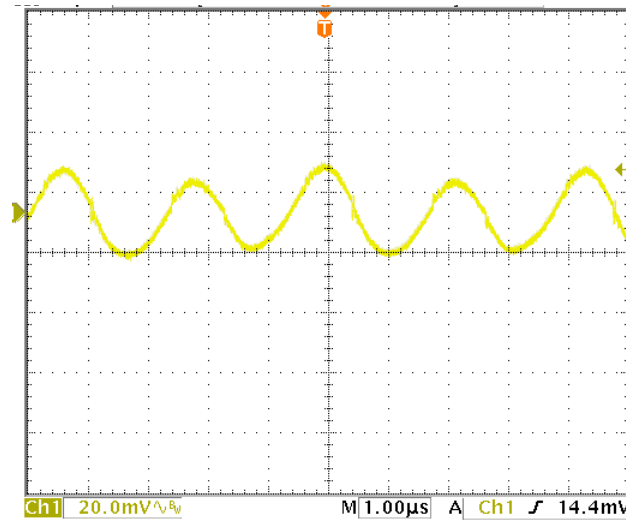

FIGURE 1. Output ripple with $I_{OUT}=6A$ with no external output capacitors

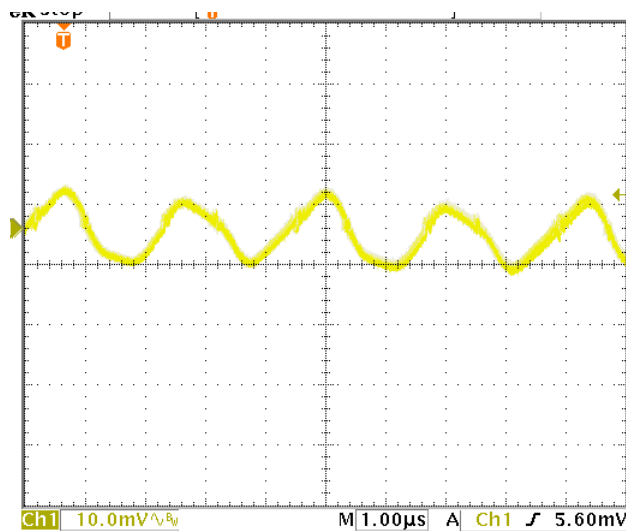

FIGURE 2. Output ripple with $I_{OUT}=6A$ with $47\mu F@25V$ external output capacitors

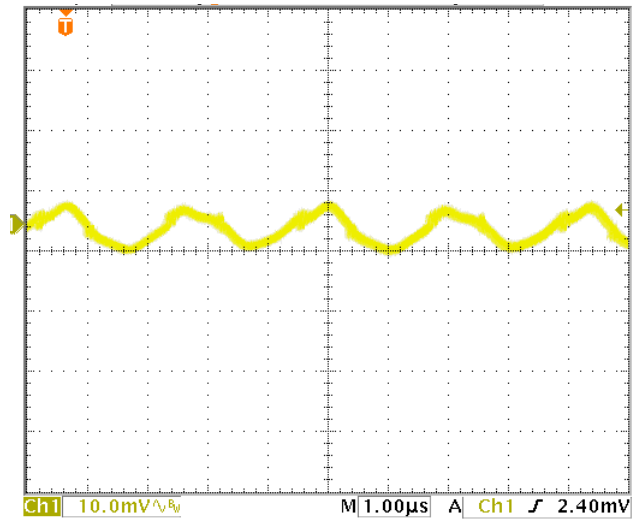

FIGURE 3. Output ripple with $I_{OUT}=6A$ with $47\mu F@25V$ and $180\mu F@16V$ external output capacitors in parallel.

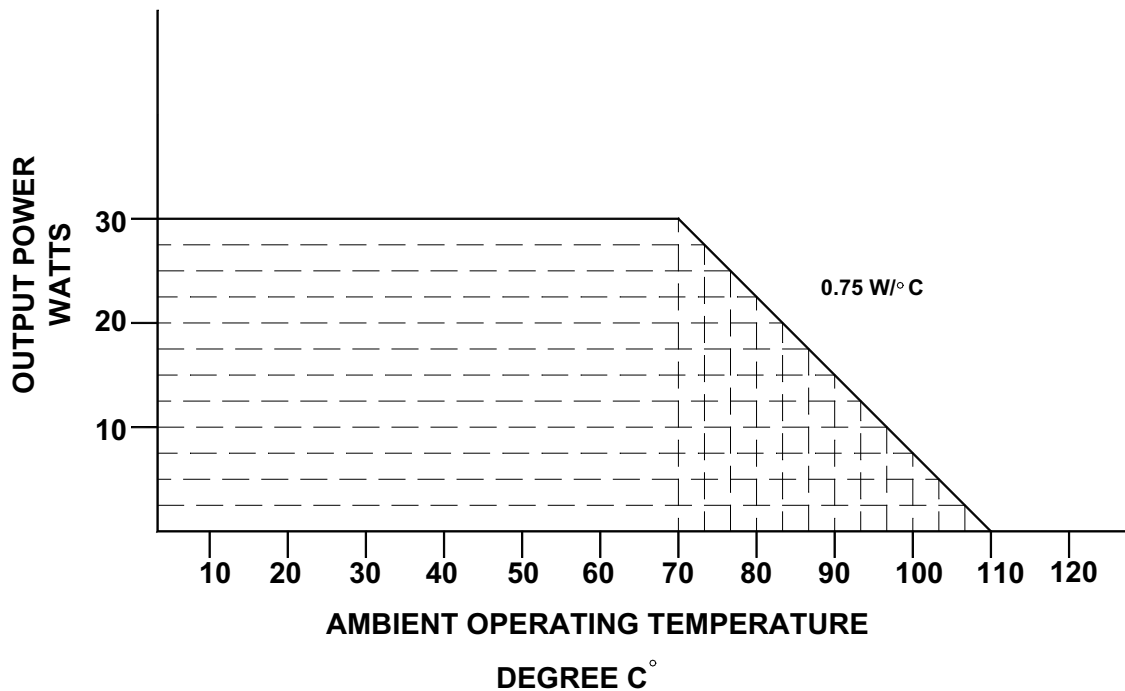

FIGURE 4. Worse case derating for the EBL30002 series

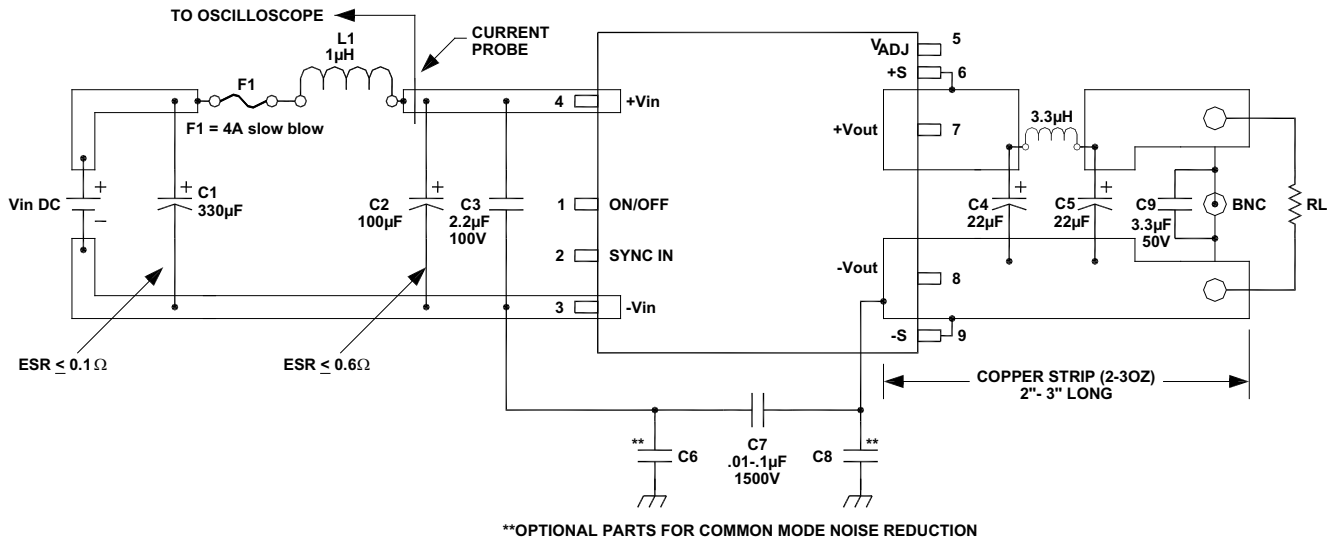

FIGURE 5. Typical setup to further reduce the output ripple for the EBL30002.

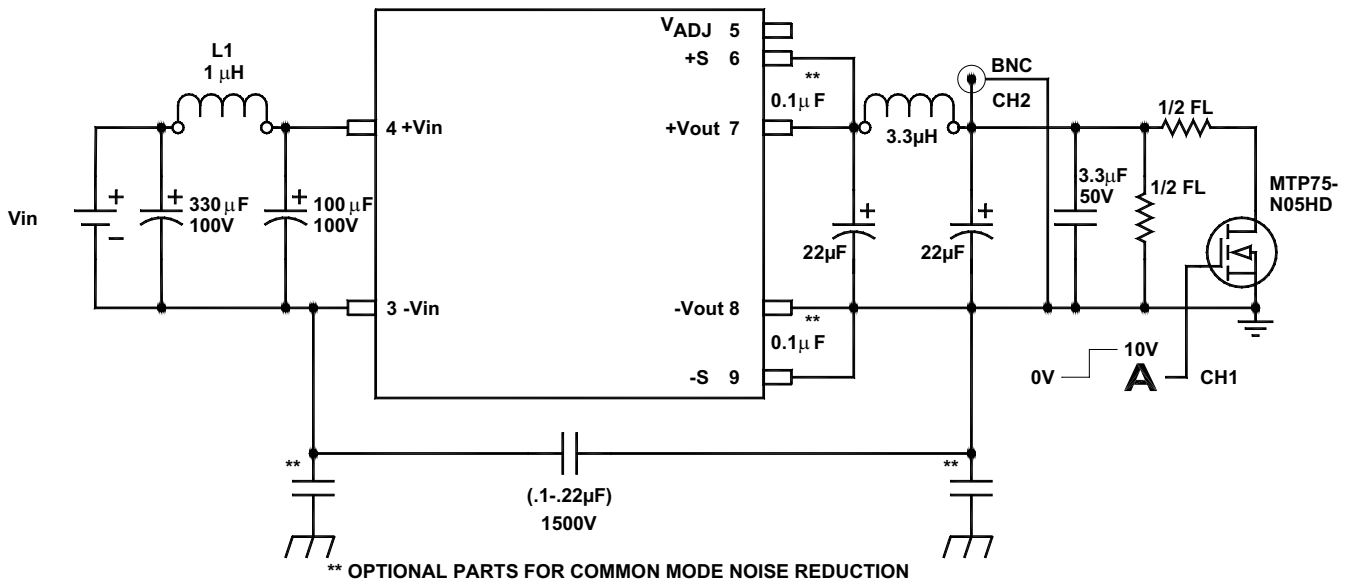

FIGURE 6. Setup for transient response measurements

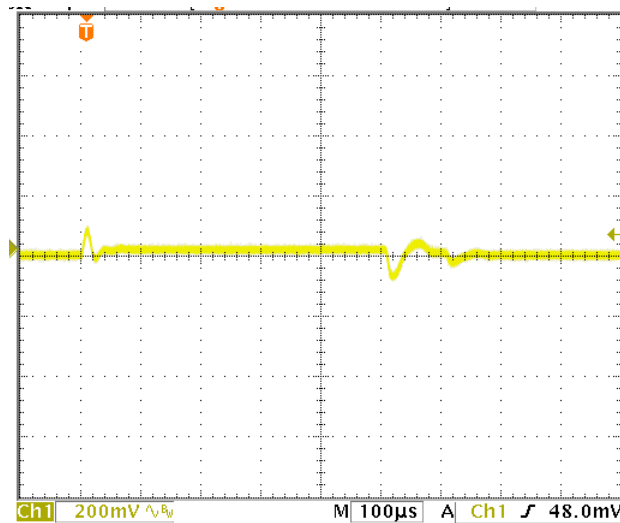

FIGURE 7. Transient response 50% full load to full load to 50% full load

EXTERNAL SYNCHRONIZATION

The converter can be synchronized to an external clock. The external clock MUST have a higher frequency than that of the converter's switching frequency. The amplitude of the external clock pulse must be 3.7 volts or greater and its duration between 15nS to 150nS for sync pulse detection.

The circuit in Figure 8 can be used to produce a 50nS to 150nS pulse from a square wave. The circuit will be turned on by the negative edge of the square wave and will stay on for approximately 50nS (depending on the $R2 \cdot C1$ time constant) (See Figure 9).

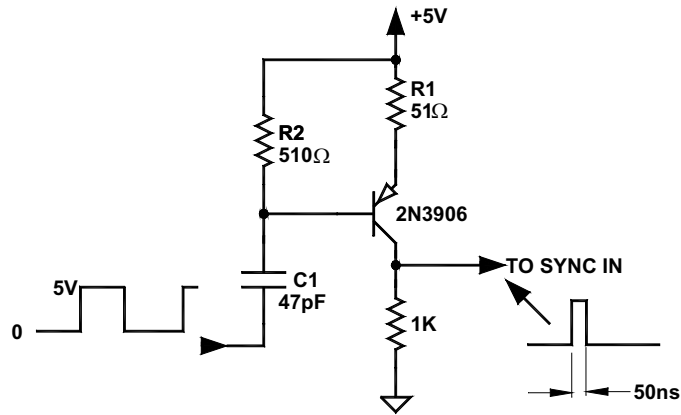

FIGURE 8. 50ns pulse generator from a square wave TTL/5V CMOS clock

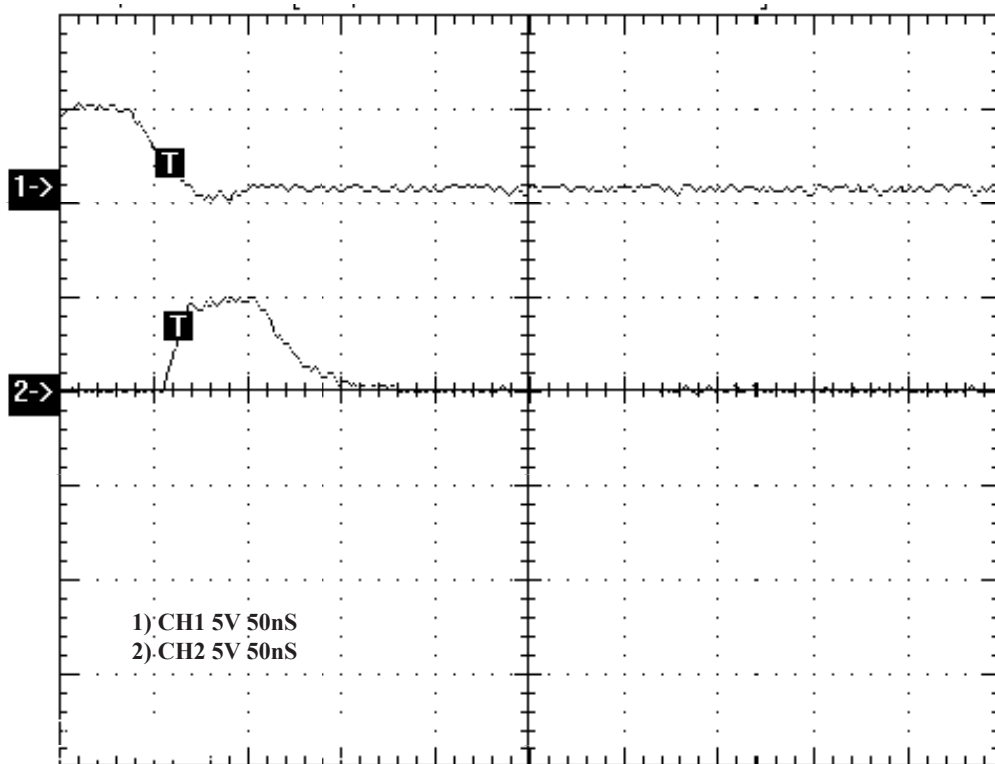
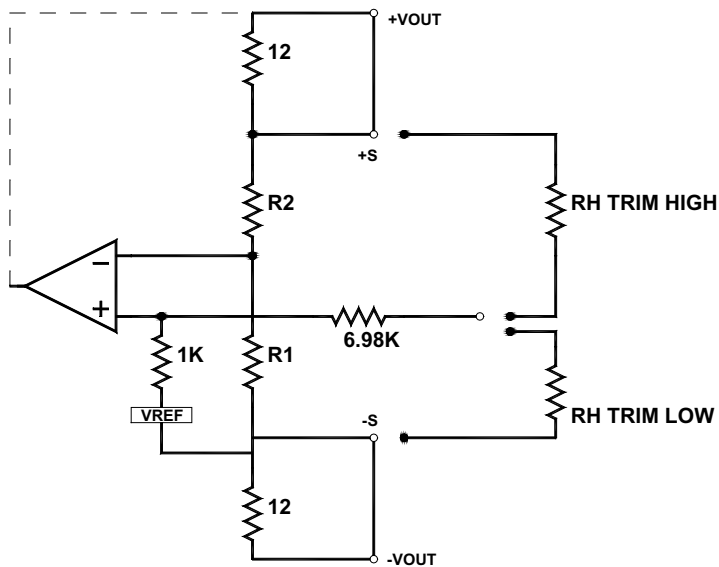

FIGURE 9. Waveforms generated from circuit in Figure 8



$$RH = \frac{\frac{R2}{R1}}{1 - \frac{VREF}{Vo} \left(\frac{R1+R2}{R1} \right)} - 10 \quad \text{in } k\Omega$$

$$RL = \frac{1}{\frac{VREF(R1+R2)}{Vo R1} - 1} - 10 \quad \text{in } k\Omega$$

VO	VREF	R2	R1
5V	2.5	2.49K	2.49K

FIGURE 10. Output adjustment equations for the EBL30002

MECHANICAL SPECIFICATIONS

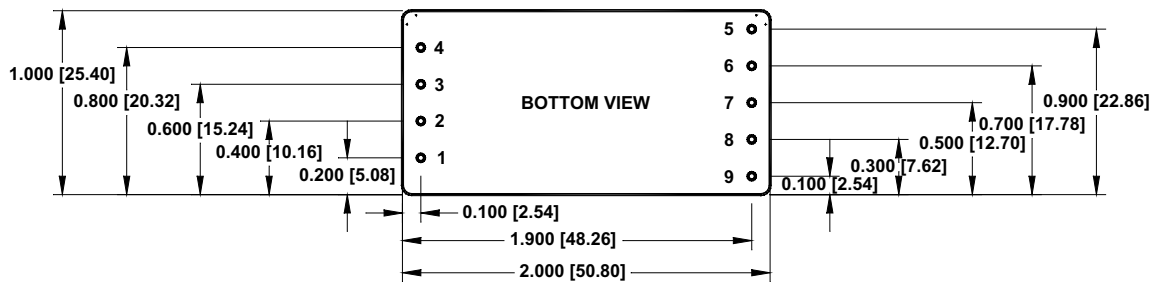
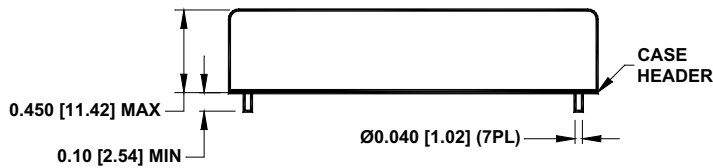

Pin	Function
INPUT	
1	ON/OFF
2	SYNC IN*
3	-V _{IN}
4	+V _{IN}
OUTPUT	
5	V _{ADJ}
6	+S
7	+V _{OUT}
8	-V _{OUT}
9	-S

DIMENSIONS ARE IN INCH(mm)
 TOLERANCE: .XX ±.02(.508)
 .XXX ±.01(.254)