



LN10014

LOW-NOISE 10W DUAL DC/DC CONVERTER

No Derating from -55°C to +85°C

US Patent 5,777,519

Key Features

- Wide input voltage range (3:1)
- Less than 5mV output noise
- 84% efficiency
- Six-sided shielding
- Soft start
- Dual output
- Short circuit protection
- Adjustable output
- 1.75mA off state current
- 250mV dropout linear regulators
- Dual output tracking linear regulator
- 5μS transient response
- Industry pinouts



Functional Description

The LN10014 is a dual output, isolated DC/DC converter that accepts $9V_{IN}$ to $30V_{IN}$ and provides $\pm 15V_{OUT}$ @ 330mA. The converter's design is based on Beta Dyne's patents and offers low noise and an extended operating temperature range from $-40^{\circ}C$ to $+71^{\circ}C$.

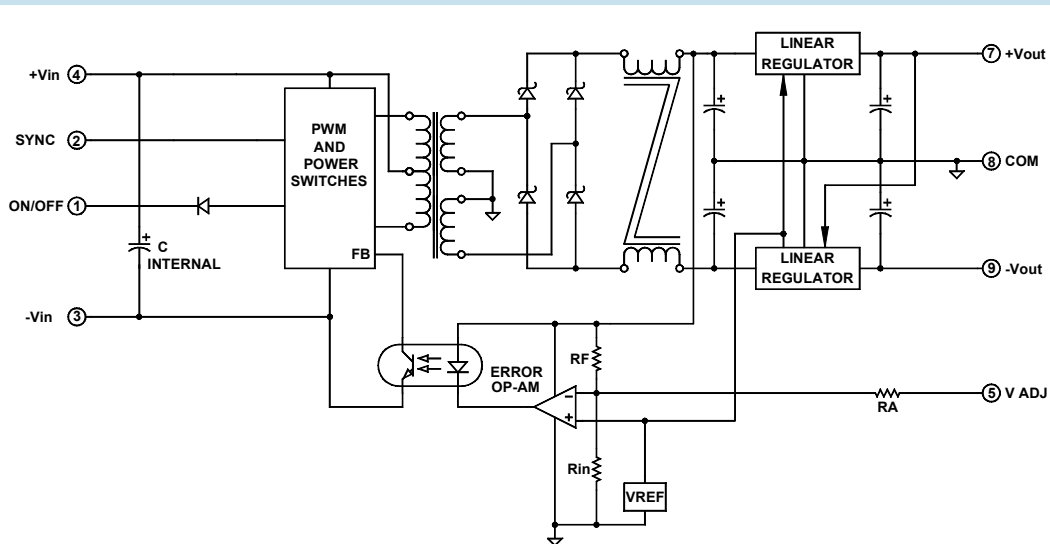

Typical Block Diagram of Dual Output Converter

Electrical Specifications

Unless otherwise specified, all parameters are given under typical +25°C with nominal input voltage and under full output load conditions.

INPUT SPECIFICATIONS

PARAMETER	CONDITION / NOTE	MIN	TYP	MAX	UNIT
Input Voltage Range		9	24	30	Vdc
No Load Input Current			20		mA
Full Load Input Current	$V_{IN} = 28V@FL (\pm 250mA)$		496		mA
Input Filter	C				
Reverse Polarity Input Current	External series-blocking diode			12	A
Input Surge Current (20 μ S Spike)				10	A
Short Circuit Current Limit			150		% I_{IN}
Undervoltage Shutdown		4.5			Vdc
Off State Current			1.75		mA
Remote ON/OFF Control					
Converter ON	Open (Open circuit voltage at Pin 1: 10V Max.)				
Converter OFF		-0.6	0	0.2	Vdc
Logic Input Reference	-Input				
Logic Compatibility	TTL Open Collector or CMOS Open Drain				

OUTPUT SPECIFICATIONS

PARAMETER	CONDITION / NOTE	MIN	TYP	MAX	UNIT
Output Voltage			± 15		Vdc
Output Voltage Accuracy			± 1	± 1.5	%
Output Voltage Adjustment			3	± 5	%
Voltage Balance, Dual ¹			± 0.2	± 0.5	%
Output Current	FL		330		mA
Minimum Load ¹		10			% of FL
Ripple & Noise	See Figure 3		5	10	mV _{pp}
Line Regulation	Minimum V_{IN} to maximum V_{IN}		0.05	0.1	%
Load Regulation ²			± 1		%
Temperature Coefficient @ FL			0.02		%/°C of V_{OUT}
Transient Response Time (to within 0.5% of V_{OUT})	50% FL to FL to 50% FL, See Figure 1		5		μ S
Short Circuit Protection	All outputs, by input current limiting				

¹ In applications where the $-V_{OUT}$ is loaded more than $+V_{OUT}$, a minimum load is required between $+V_{OUT}$ and GND. If the load is connected between $+V_{OUT}$ and $-V_{OUT}$, no minimum load is required.

² For dual converters if only the $-V_{OUT}$ is loaded. A 10% FL must be connected from $+V_{OUT}$ to Ground.

GENERAL SPECIFICATIONS

PARAMETER	CONDITION / NOTE	MIN	TYP	MAX	UNIT
Efficiency	$V_{IN} = 28V, I_o = \pm 250mA$		84		%
Isolation Voltage (1 min.)			1500		Vdc
Isolation Resistance			10^9		Ω
Isolation Capacitance			80		pF
Switching Frequency		300	320	333	kHz

ENVIRONMENTAL SPECIFICATIONS

PARAMETER	CONDITION / NOTE	MIN	TYP	MAX	UNIT
Operating Temperature, Extended (X)		-55		+85	°C
Storage Temperature Range		-55		+125	°C
Thermal Resistance			3.5	4	°C/W _{DISS}
Maximum Operating Case Temperature				105	°C
Humidity	Up to 95% non-condensing				
Cooling	Free-air convection				
EM/RFI	Six-sided continuous shielded metal case				
MTBF	per MIL-HNBK-217F (Ground benign, +25°C)		1×10^6		hours

PHYSICAL CHARACTERISTICS

PARAMETER	CONDITION / NOTE	MIN	TYP	MAX	UNIT
Dimensions (L×W×H)	2.00×1.00×0.395 in. (50.80×25.40×10.03mm)				
Weight	1.04 oz. (30g)				
Case Material	Coated metal				
Shielding Connection	-Input (Pin 3)				

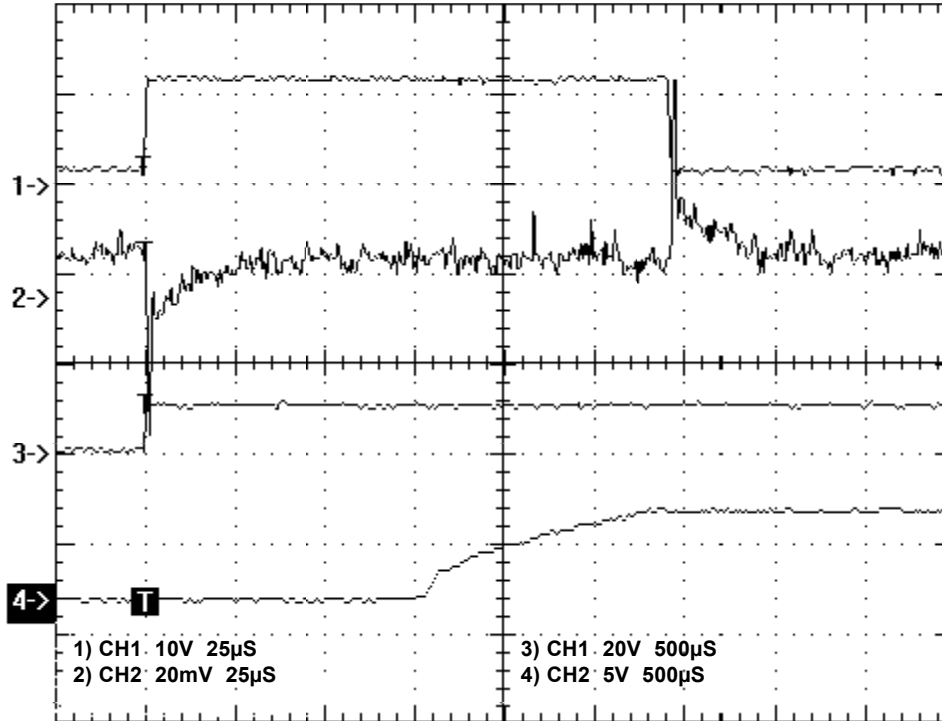

FIGURE 1. Transient response and turn on delay with soft start

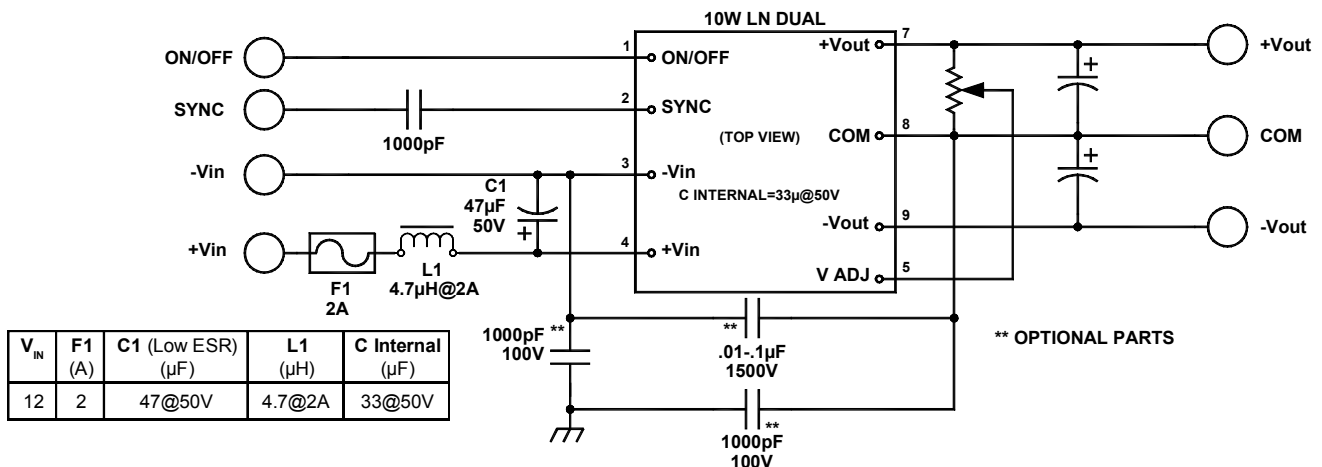
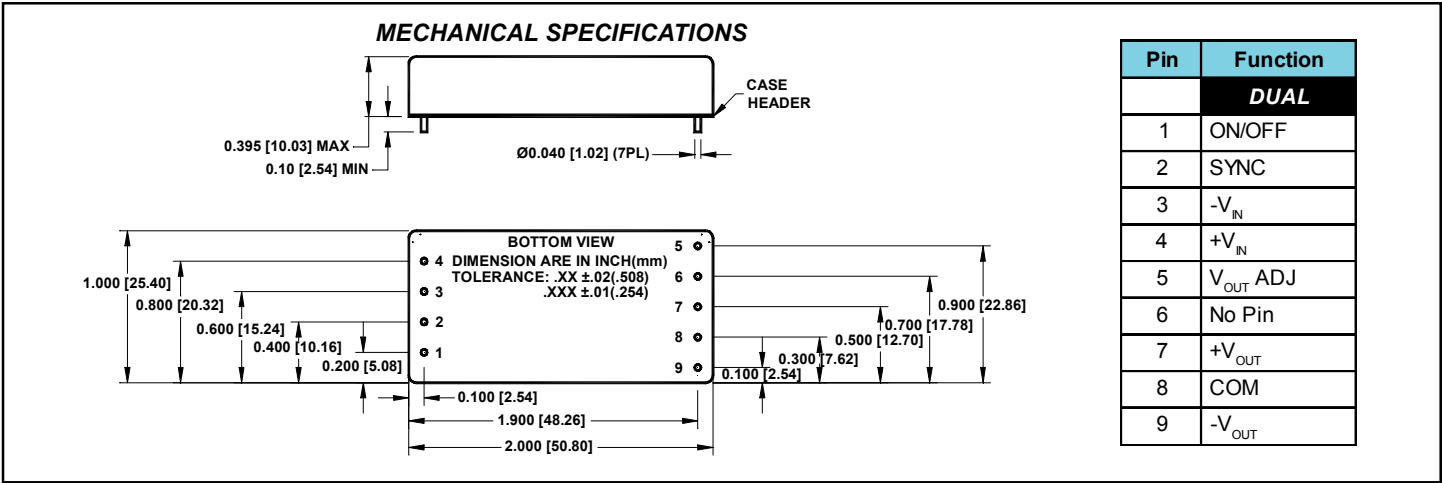

FIGURE 2. Typical connection diagram of Low-Noise 10W Dual DC/DC Converter



OUTPUT VOLTAGE ADJUSTMENT

For both single and dual models, the output reference voltage is referenced to the output ground: Pin 6 for singles and Pin 8 for duals. To trim the output voltage high, connect a 1% resistor (0kΩ–200kΩ range) between -V_{OUT} (Pin 6) and V_{OUT} Adjust (Pin 9) for the singles, and COM (Pin 8) and V_{OUT} Adjust (Pin 5) for the duals. To trim the output voltage low, connect a 1% resistor (50kΩ–500kΩ range) between +V_{OUT} (Pin 5) and V_{OUT} Adjust (Pin 9) for

the singles, and +V_{OUT} (Pin 7) and V_{OUT} Adjust (Pin 5) for the duals. With the wiper connected to the V_{OUT} Adjust pin, a variable resistor (potentiometer) can also be used for V_{OUT} adjustment by connecting each end to +V_{OUT} and -V_{OUT} for the singles, and +V_{OUT} and COM for the duals. A potentiometer between 50kΩ–100kΩ can be used. Avoid using a low resistance potentiometer or a high temperature coefficient such as wound wire.

EXTERNAL SYNCHRONIZATION

This series of converters can be synchronized to an external system clock of 320kHz -2% to 10%. The external clock is AC-coupled to the input SYNC terminal (Pin 2) through a coupling

capacitor from 220pF to 1000pF. The required amplitude is 3.3V to 5V and its duty cycle is 50% ±20%. Please refer to *Application Note DC-005: Synchronization* for more information.

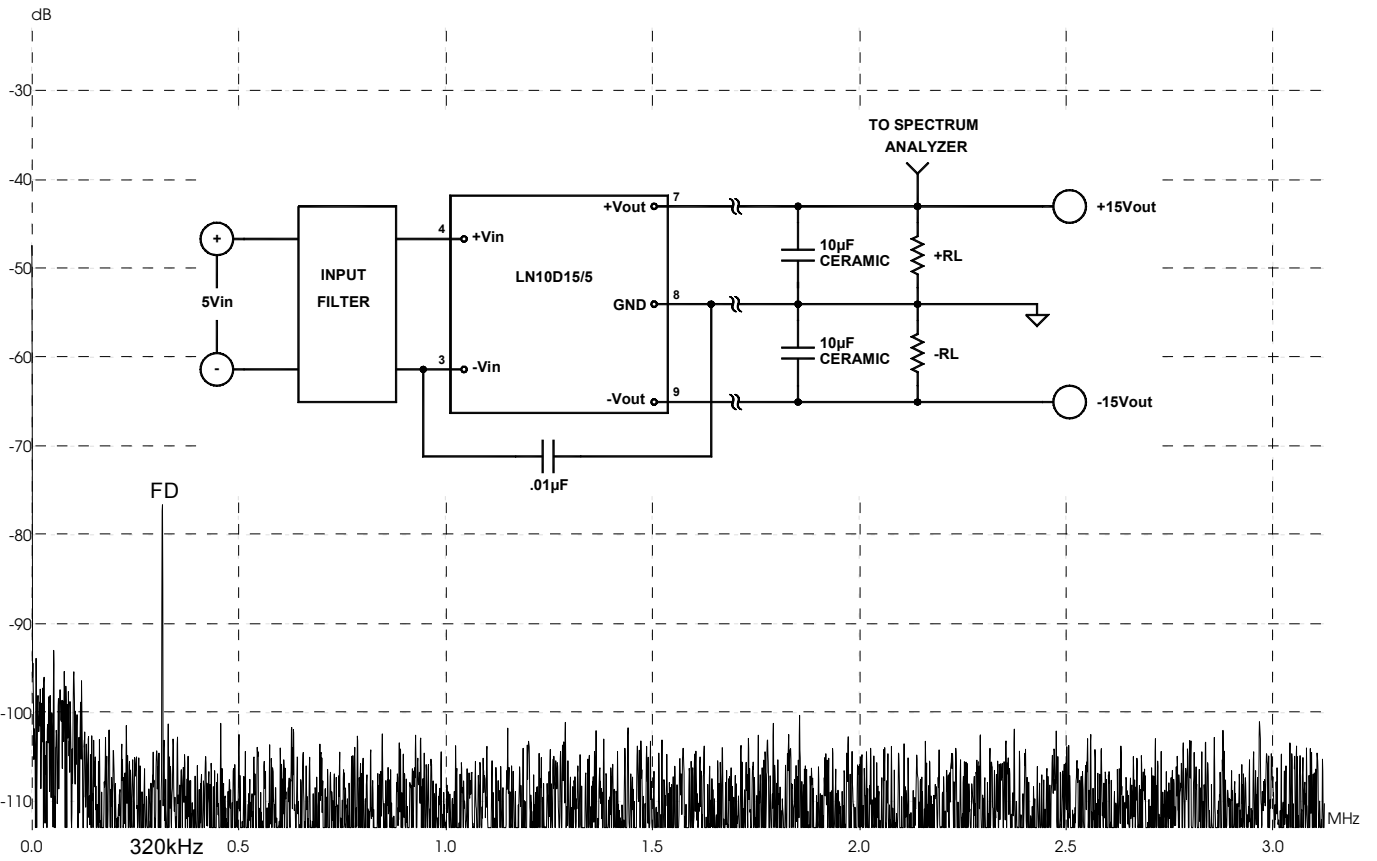

FIGURE 3. Setup and reading for output voltage noise spectrum

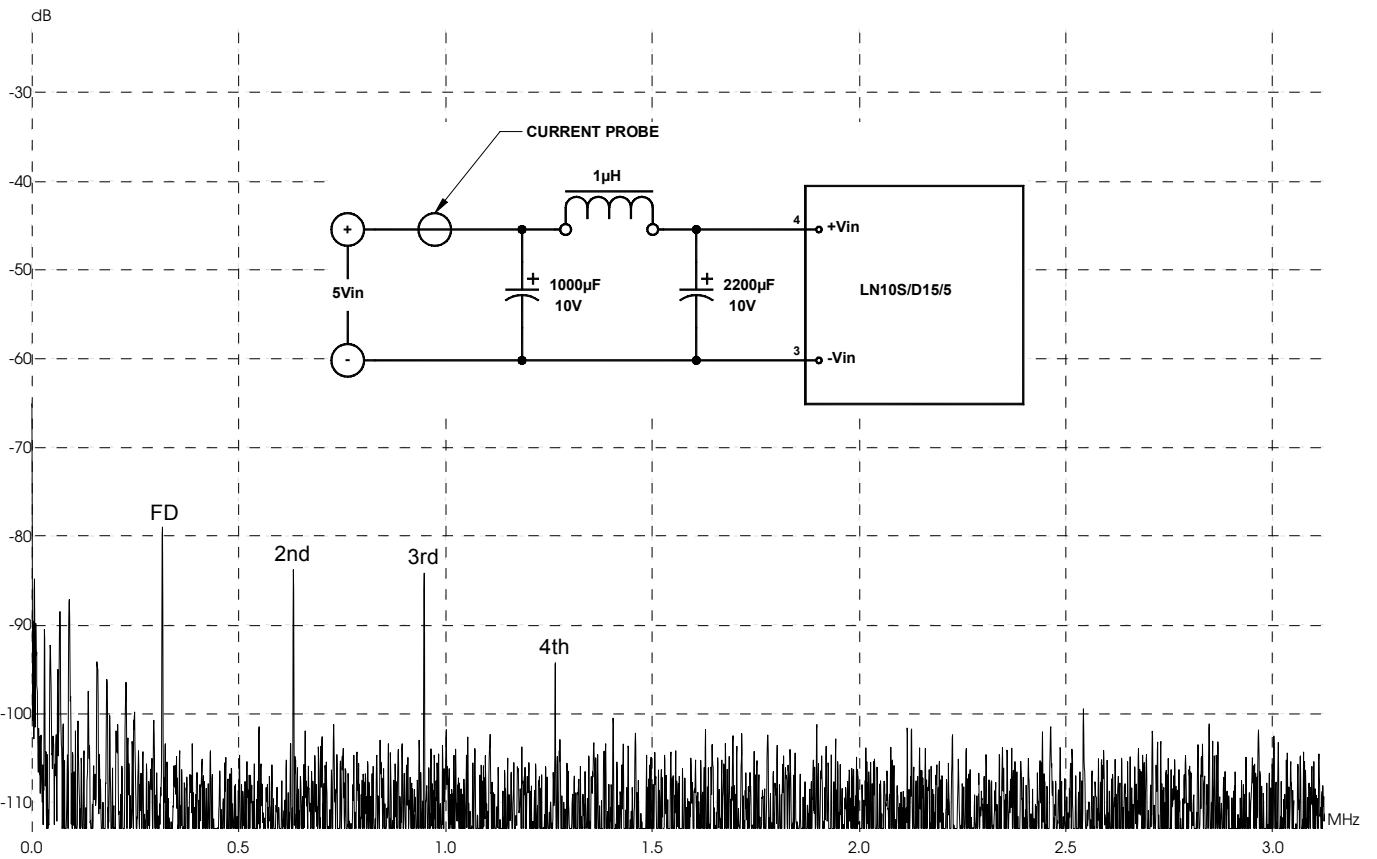

FIGURE 4. Setup and reading for reflected ripple current