



LN10025

LOW-NOISE 10W SINGLE DC/DC CONVERTER

18-36V_{IN} 8VDC@1.2A

US Patent 5,777,519

Key Features

- 10mV Output ripple
- 81% Efficiency
- Six-sided shielding
- Soft start
- Single output
- Short circuit protection
- Adjustable output
- 750μA Off state current
- 250mV Dropout linear regulators
- Industry pinouts



Functional Description

The LN10025 is an isolated, 10W low noise single DC/DC converter with an input voltage range from 18V_{IN} to 36V_{IN} and provides 8VDC@1.2A. The converter's design is based on Beta Dyne's patents and offers low noise and an operating temperature range from -40°C to +71°C.

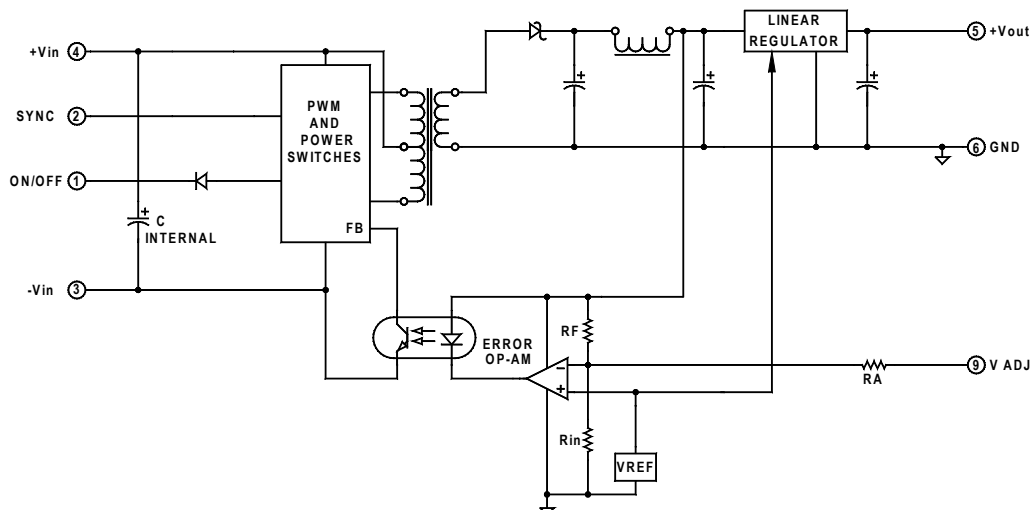

Typical Block Diagram of Single Output Converter

Electrical Specifications

INPUT SPECIFICATIONS

Unless otherwise specified, all parameters are given under typical +25°C with nominal input voltage and under full output load conditions.

PARAMETER	CONDITION / NOTE	MIN	TYP	MAX	UNIT
Input Voltage Range		18	24	36	Vdc
Input Filter	C				
No Load Input Current			10		mA
Full Load Input Current			510		mA
Reverse Polarity Input Current	External series-blocking diode			12	A
Input Surge Current (20µs Spike)				10	A
Short Circuit Current Limit			150		% I _{IN}
Undervoltage Shutdown		4.5			Vdc
Off State Current			750		µA
Remote ON/OFF Control					
Converter ON	Open (Open circuit voltage at Pin 1: 10V Max.)				
Converter OFF		-0.6	0	0.2	Vdc
Logic Input Reference	-Input				
Logic Compatibility	TTL Open Collector or CMOS Open Drain				

OUTPUT SPECIFICATIONS

PARAMETER	CONDITION / NOTE	MIN	TYP	MAX	UNIT
Output Voltage			8.0		Vdc
Output Voltage Accuracy			±1	±1.5	%
Output Voltage Adjustment			±3	±10	%
Output Current			1.2		A
Ripple & Noise	As shown in Figure 3		10		mV _{pp}
Line Regulation	Minimum V _{IN} to maximum V _{IN}		1		%
Load Regulation	NL to FL		1		%
Temperature Coefficient @ FL			0.02		%/°C of V _{OUT}
Transient Response Time (to within 0.5% of V _{OUT})	50% FL to FL to 50% FL, See Figure 1		5		µs
Short Circuit Protection	All outputs, by input current limiting				

GENERAL SPECIFICATIONS

PARAMETER	CONDITION / NOTE	MIN	TYP	MAX	UNIT
Efficiency			81		%
Isolation Voltage (1 min.)			1500		Vdc
Isolation Resistance			10 ⁹		Ω
Isolation Capacitance			80		pF
Switching Frequency		300	320	333	kHz

ENVIRONMENTAL SPECIFICATIONS

PARAMETER	CONDITION / NOTE	MIN	TYP	MAX	UNIT
Operating Temperature		-40		+71	°C
Storage Temperature Range		-55		+125	°C
Thermal Resistance			3.5	4	°C/W _{DISS}
Maximum Operating Case Temperature				105	°C
Humidity	Up to 95% non-condensing				
Cooling	Free-air convection				
EMI/RFI	Six-sided shielded metal case				
MTBF	per MIL-HNBK-217F (Ground benign, +25°C)		1×10 ⁶		hours

PHYSICAL CHARACTERISTICS

PARAMETER	CONDITION / NOTE	MIN	TYP	MAX	UNIT
Dimensions(LxWxH)	2.00 x 1.00x0.395 in(50.80x25.40x10.33mm)				
Weight	1.04 oz. (30g)				
Case Material	Coated Metal				
Shielding Connection	-V _{in} (Pin3)				

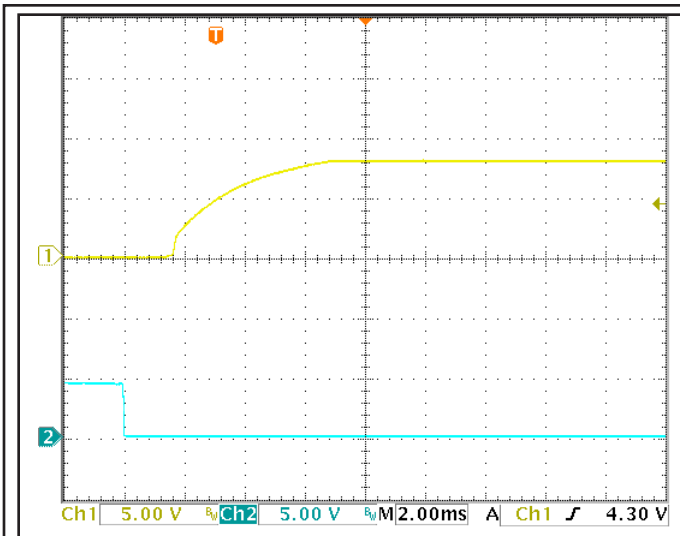

FIGURE 1. Transient response and turn on delay with soft start

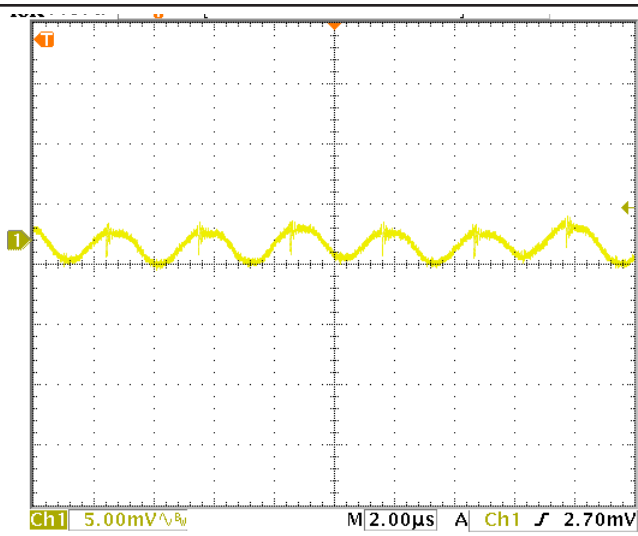

FIGURE 2. Output ripple of Figure 3

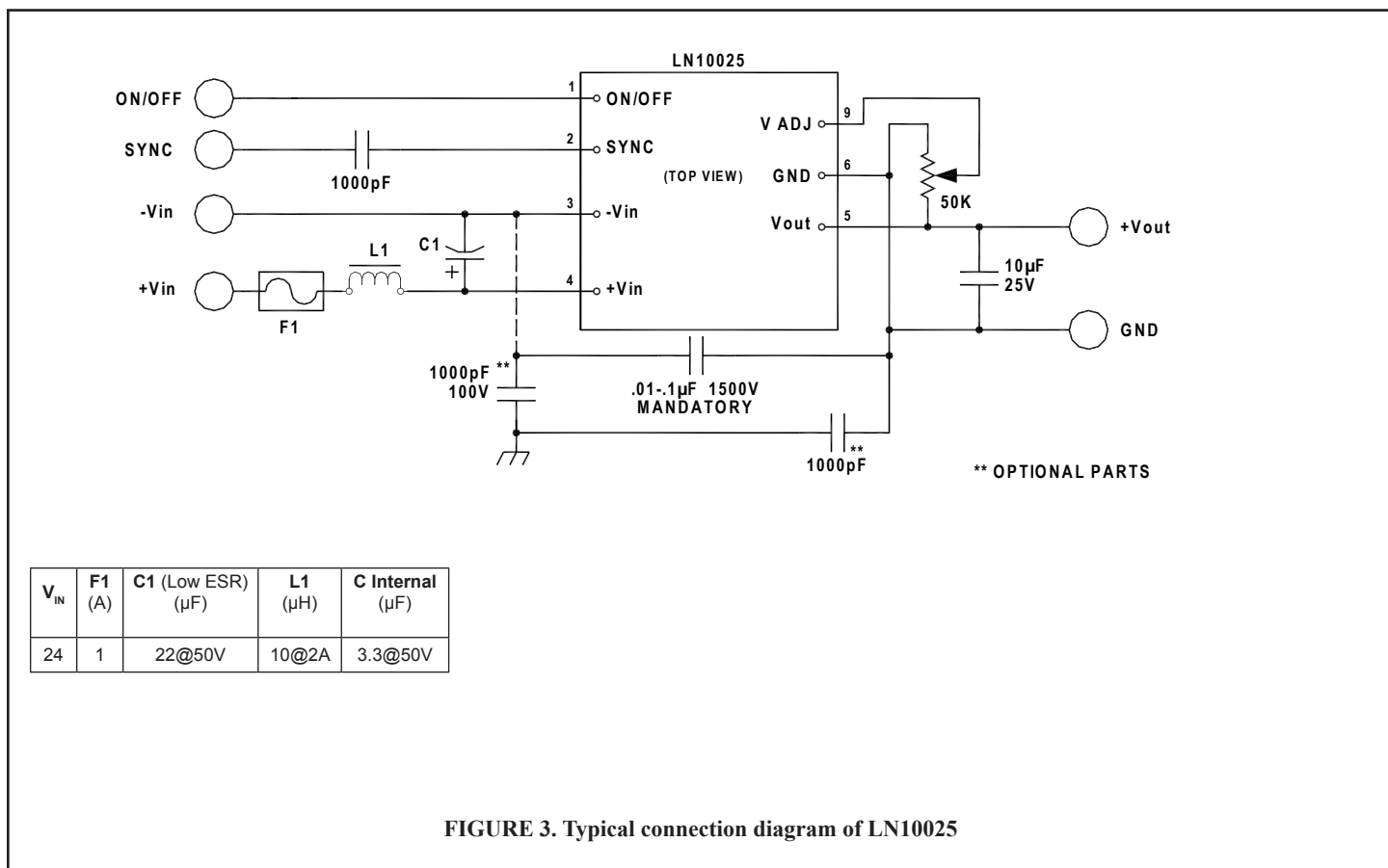
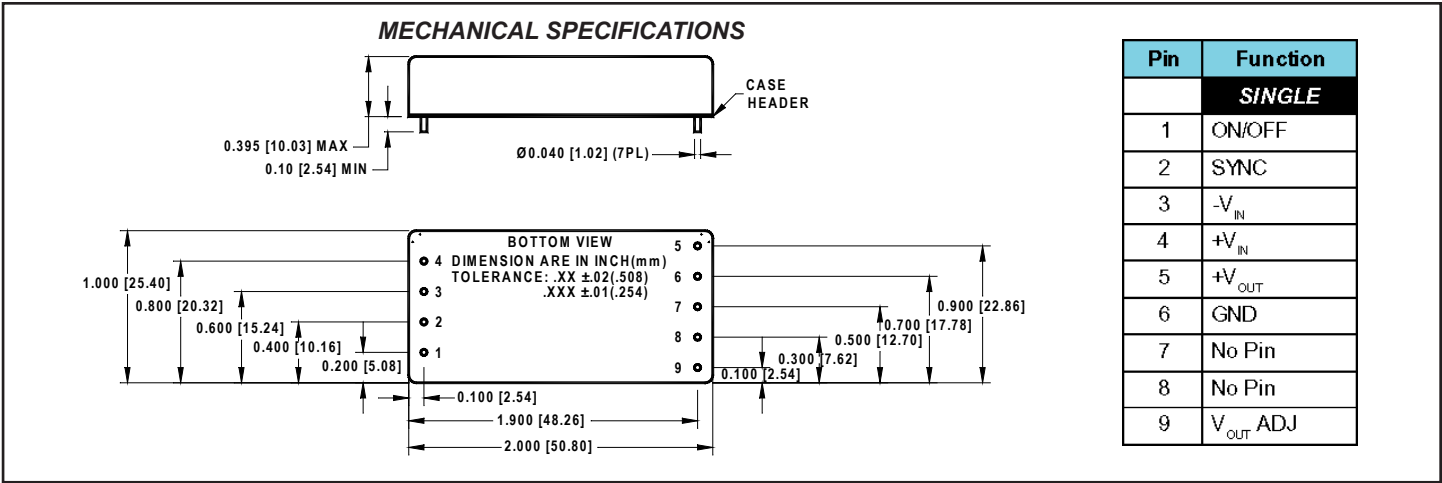

FIGURE 3. Typical connection diagram of LN10025



OUTPUT VOLTAGE ADJUSTMENT

For both single and dual models, the output reference voltage is referenced to the output ground: Pin 6 for singles and Pin 8 for duals. To trim the output voltage high, connect a 1% resistor (0kΩ–200kΩ range) between -V_{OUT} (Pin 6) and V_{OUT} Adjust (Pin 9) for the singles, and COM (Pin 8) and V_{OUT} Adjust (Pin 5) for the duals. To trim the output voltage low, connect a 1% resistor (50kΩ–500kΩ range) between +V_{OUT} (Pin 5) and V_{OUT} Adjust (Pin 9) for the singles,

With the wiper connected to the V_{OUT} Adjust pin, a variable resistor (potentiometer) can also be used for V_{OUT} adjustment by connecting each end to +V_{OUT} and -V_{OUT} for the singles, and +V_{OUT} and COM for the duals. A potentiometer between 50kΩ–100kΩ can be used. Avoid using a low resistance potentiometer or a high temperature coefficient such as wound wire.

EXTERNAL SYNCHRONIZATION

This series of converters can be synchronized to an external system clock of 320kHz -2% to 10%. The external clock is AC-coupled to the input SYNC terminal (Pin 2) through a coupling capacitor

from 220pF to 1000pF. The required amplitude is 3.3V to 5V and its duty cycle is 50% ±20%. Please refer to *Application Note DC-005: Synchronization* for more information.