



LN15003

Low-Noise 15W DC/DC CONVERTER

18–36V_{IN} 15V_{OUT} with ±0.5% Output Voltage Accuracy
 Patent No.: US 5,777,519

Key Features

- Less than 5mV output noise
- 88% efficiency
- Six-sided shielding
- Soft start
- Single
- Short circuit and thermal protection
- Adjustable output
- 750µA off state current
- Wide input voltage range (2:1)
- 250mV dropout linear regulators

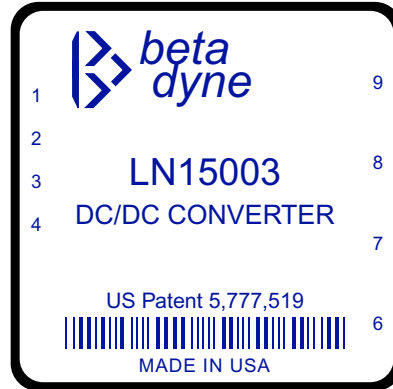

Functional Description

The LN15003 is a low-noise, single output 15W DC/DC converter that accepts 18–36V_{IN} and provides 15V_{OUT}. The output accuracy is trimmed to be within ±0.5% of V_{OUT} at room temperature. Low dropout linear regulators reduce the output noise to 5mV_{PP}. A patented control circuit maintains minimum constant dropout voltage over line, load, temperature and output adjust range.

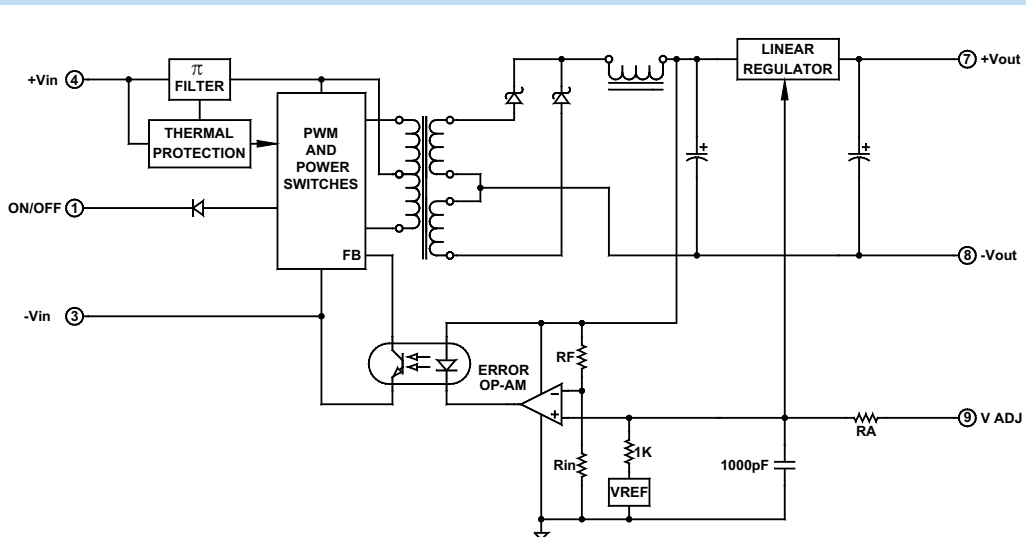

Typical Block Diagram

Electrical Specifications

INPUT SPECIFICATIONS

Unless otherwise specified, all parameters are given under typical +25°C with nominal input voltage and under full output load conditions.

PARAMETER	CONDITION / NOTE	MIN	TYP	MAX	UNIT
Input Voltage Range		18	24	36	Vdc
No Load Input Current			10		mA
Full Load Input Current			720		mA
Input Filter					
Reverse Polarity Input Current	External series-blocking diode			12	A
Input Surge Current (20µs Spike)				10	A
Short Circuit Current Limit			150		% I _{IN}
Undervoltage Shutdown			8		Vdc
Off State Current, 24V			750		µA
Remote ON/OFF Control					
Converter ON	Open (Open circuit voltage at Pin 1: 10V Max.)				
Converter OFF		-0.6	0	0.2	Vdc
Logic Input Reference	-Input				
Logic Compatibility	TTL Open Collector or CMOS Open Drain				

OUTPUT SPECIFICATIONS

PARAMETER	CONDITION / NOTE	MIN	TYP	MAX	UNIT
Output Voltage		14.925	15.000	15.075	Vdc
Output Voltage Accuracy				±0.5	%
Output Voltage Adjustment			3	±5	%
Output Current			100		mA
Ripple & Noise			5	10	mV _{pp}
Line Regulation	Minimum V _{IN} to maximum V _{IN}		0.05	0.1	%
Load Regulation	NL to FL		0.05	0.1	%
Temperature Coefficient @ FL			0.02		%/°C
Transient Response Time (to within 0.5% of V _{OUT})	50% FL to FL to 50% FL, See Figure 1		5		µS
Short Circuit Protection	All outputs, by input current limiting				
Output Short Circuit Duration	Continuous				

GENERAL SPECIFICATIONS

PARAMETER	CONDITION / NOTE	MIN	TYP	MAX	UNIT
Efficiency			88		%
Isolation Voltage (1 min.)			1500		Vdc
Isolation Resistance			10 ⁹		Ω
Isolation Capacitance			80		pF
Switching Frequency			100		kHz

ENVIRONMENTAL SPECIFICATIONS

PARAMETER	CONDITION / NOTE	MIN	TYP	MAX	UNIT
Operating Temperature, Industrial (Ambient)*	See Figure 2	-40		+75	°C
Storage Temperature Range		-55		+125	°C
Thermal Resistance			3.5	4	°C/W _{DISS}
Maximum Operating Case Temperature				105	°C
Thermal Turn Off, Case Temperature		95	100	115	°C
Thermal Hysteresis			20		°C
Derating	See Figure 2				
Humidity	Up to 95% non-condensing				
Cooling	Free-air convection				
EMI/RFI	Six-sided continuous shielded metal case				
MTBF	per MIL-HNBK-217F (Ground benign, +25°C)		625,000		hours

* See footnotes 1, 2, 3 and 4.

PHYSICAL CHARACTERISTICS

PARAMETER	CONDITION / NOTE	MIN	TYP	MAX	UNIT
Dimensions (L×W×H)	2.00×2.00×0.395 in. (50.80×50.80×10.03mm)				
Weight	2 oz. (58g)				
Case Material	Coated metal				
Shielding Connection, 24V _{IN}	-Input (Pin 3)				

¹ Contact factory for -55° to +85°C operating temperature range.

² The maximum input current at any given input range measured at minimum input voltage is given as 1.6*I_{NOMINAL}. Nominal input current is the typical value measured at the input of the converter under full-load room temperature and nominal input voltage (5, 12, 24 and 48V_{IN}).

³ Adequate insulation is to be provided to the converters at the end usage as per applicable requirements.

⁴ Temperature rise on the case of the converters is to be considered during the end usage as per applicable requirements.

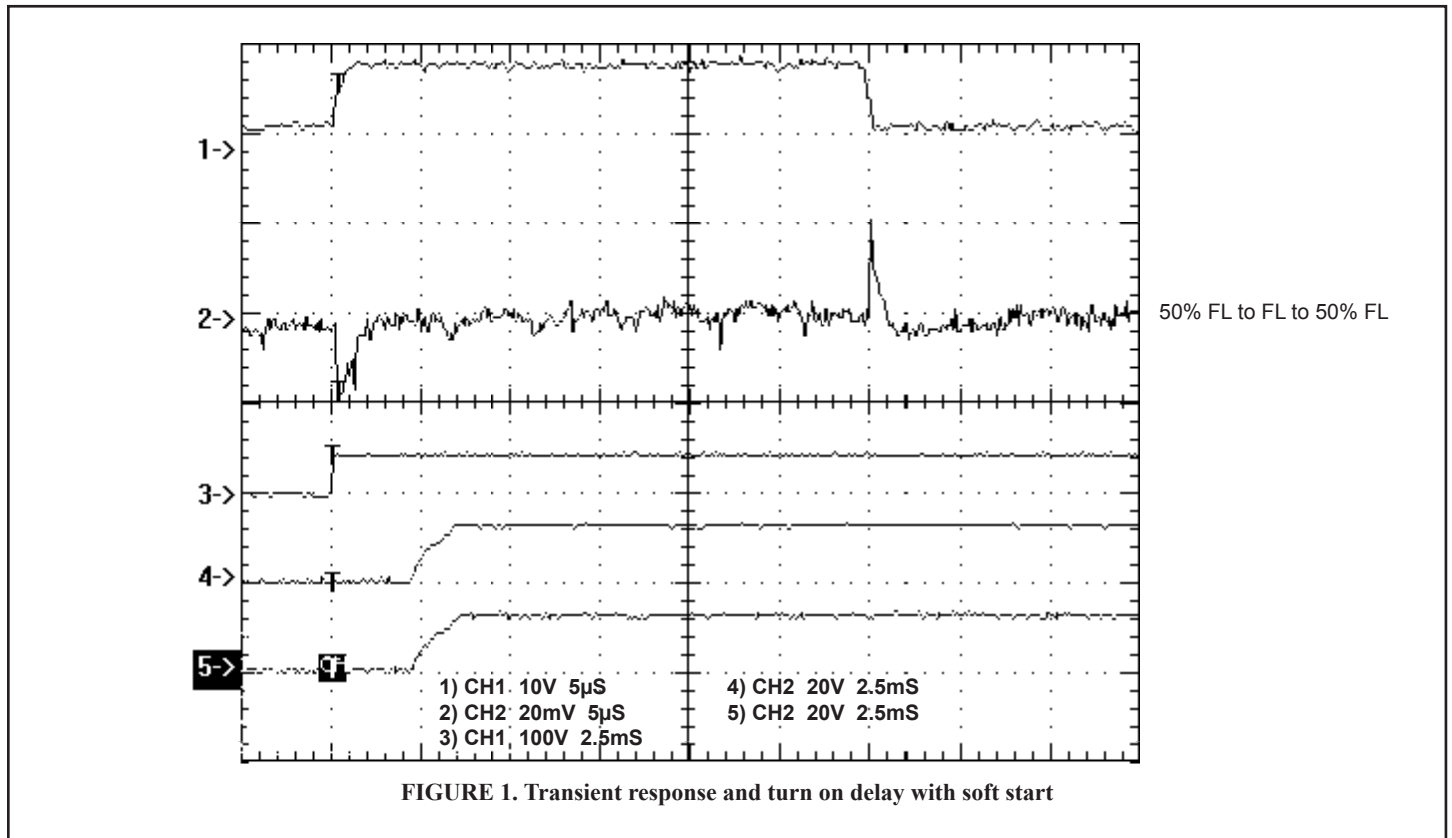

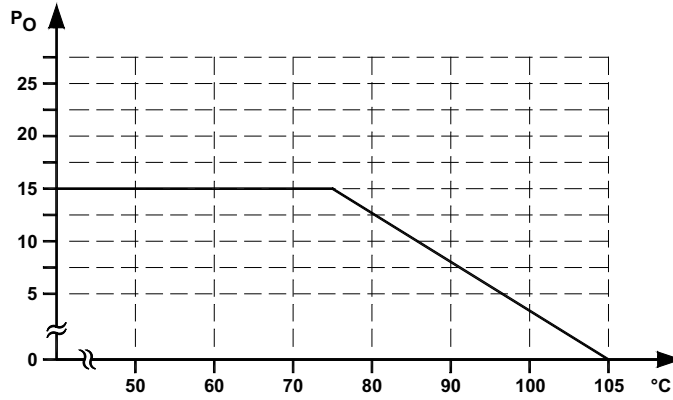

FIGURE 2. Typical derating curve

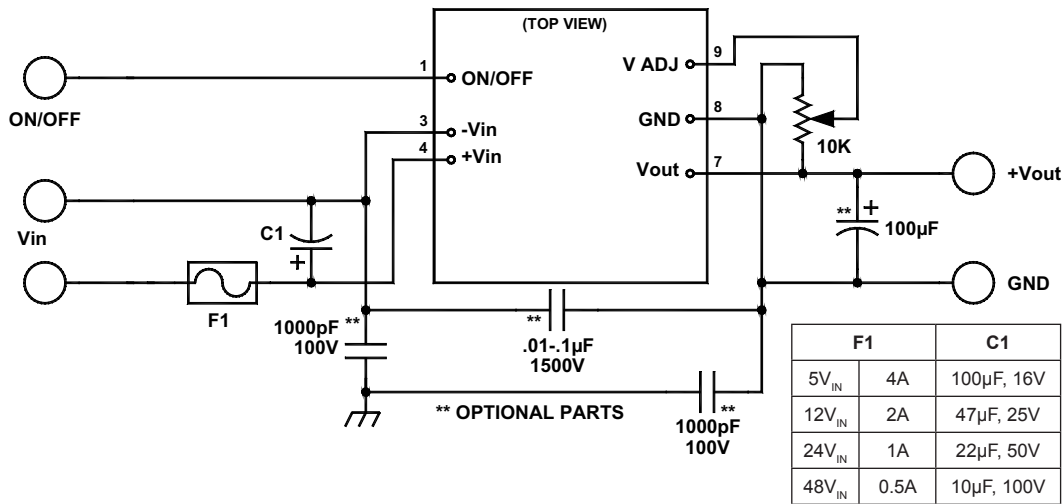
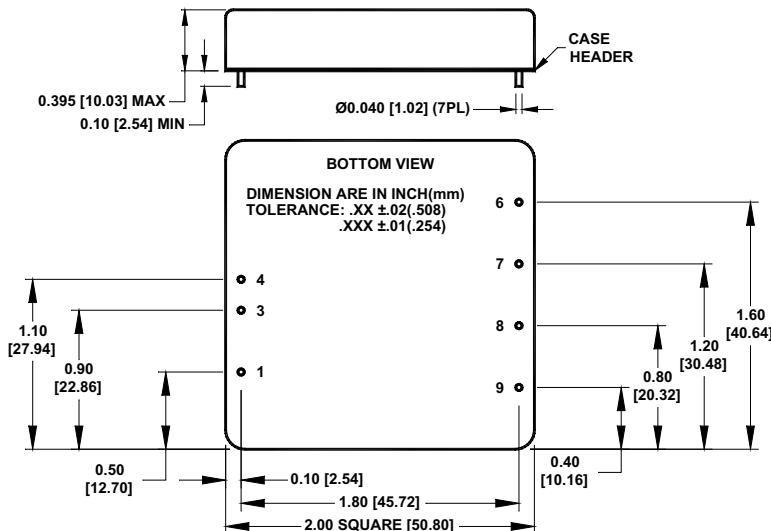

FIGURE 3. Typical connection diagram

MECHANICAL SPECIFICATIONS



Pin	Function
SINGLE	
1	ON/OFF
2	No Pin
3	-V _{IN}
4	+V _{IN}
5	No Pin
6	No Pin
7	+V _{OUT}
8	-V _{OUT}
9	V _{ADJ}

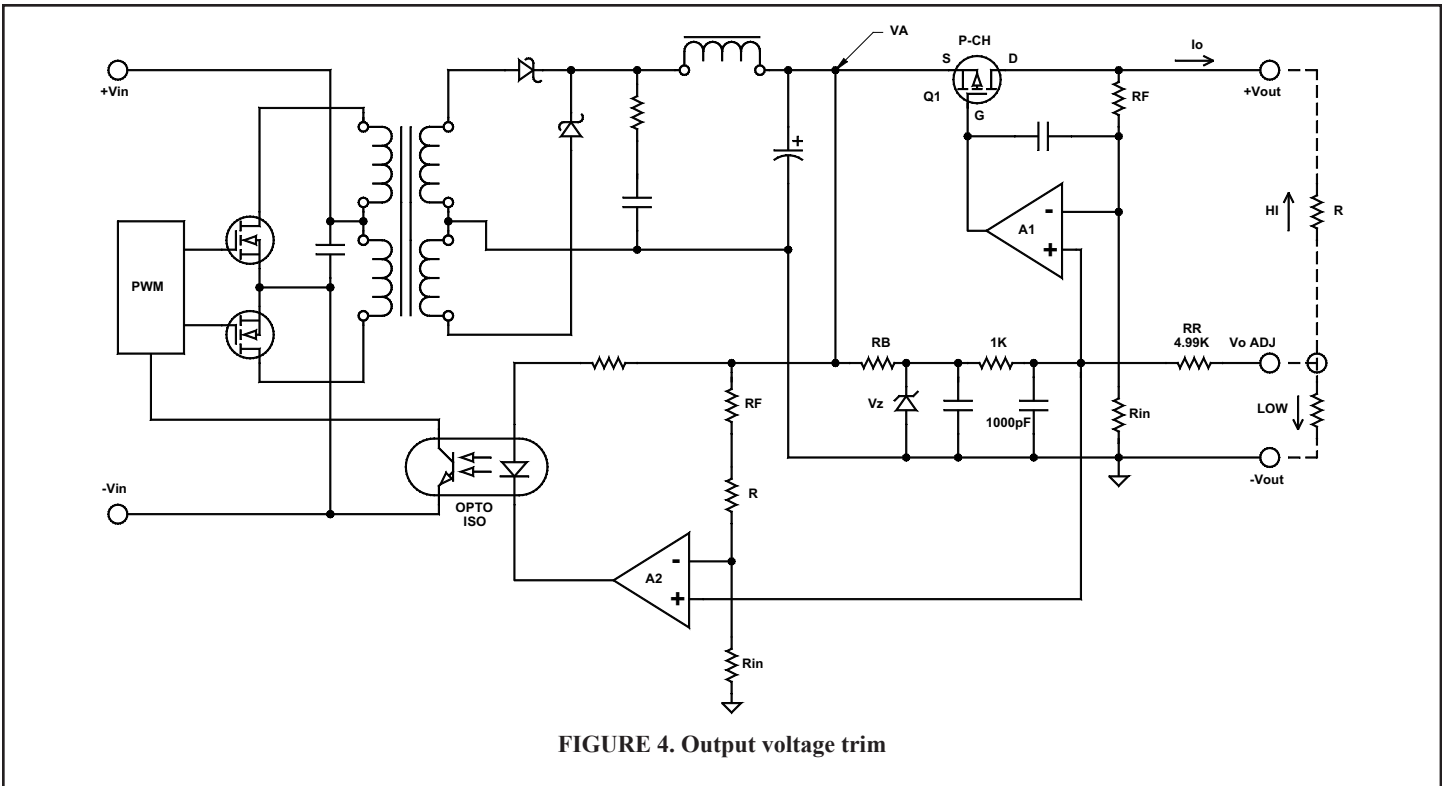

FIGURE 4. Output voltage trim

OUTPUT VOLTAGE TRIM

The LN series features a unique output control circuit that maintains constant the drop out voltage of its linear regulator in order to minimize internal power dissipation and to maximize the efficiency of the converter. The same voltage reference is driving both the linear regulator and the error amplifier of the converter. The voltage reference is referenced to the output ground for the single and dual converters, and the positive input of both error amplifiers of the linear regulator and converter are adjusted through the V_o Adjust pin.

As shown in Figure 4, the positive input of the error amplifier is biased through 1kΩ 1% resistors from the voltage reference. When the output is adjusted (trimmed), a voltage divider is formed by the 1K and RA. To trim the output high, the resistor calculated from the formula below is inserted between the $+V_{OUT}$ and V_o Adjust pins. To trim the output low, the selected resistor is placed between the Ground and V_o Adjust pins.

$$R \text{ Trim (in k}\Omega) \text{ HI} = \frac{1-\alpha}{\frac{\alpha * V_{REF}}{V_o H} - 1} - 4.99$$

$$R \text{ Trim (in k}\Omega) \text{ LOW} = \frac{1}{\frac{\alpha * V_{REF}}{V_o L} - 1} - 4.99$$

where α is given in Table 1.

EXAMPLE: A single 15V_{OUT} converter needs to be set at 15.5V, calculate the needed external resistor:

From Table 1, $\alpha = 6$

$$R = (-5/[(6*2.5)/15.5]-1) - 4.99 = 150k\Omega$$

To trim the same converter lower to 14.5V:

$$R \text{ (in k}\Omega) = (1/[(15/14.5)-1] - 4.99 = 24k\Omega$$

TABLE 1

V_o Nominal (V)	
5, ±5	2
12, ±12	4.8
15, ±15	6