



M10001

8W ADJUSTABLE DC/DC CONVERTER 24-PIN DIP

$24V_{IN}$ -6.8 to $-45V_{OUT}$
 $2mV_{PP}$ Output Ripple

Key Features

- Efficiency 84%
- 1000Vdc isolation
- Short circuit and thermal protection
- 2:1 input voltage range
- Metal case
- Six-sided shielding
- 2mA off state current
- Industry standard pinout



Beta Dyne is protected under various patents, including but not limited to U.S. Patent numbers: 5,777,519; 6,188,276; 6,262,901; 6,452,818; 6,473,3171.

Applications

- High-Voltage Power Amplifiers
- Micro-Machine Drivers
- Micro Mirrors
- Piezoelectric Transducers

Functional Description

The M10001 is an adjustable DC/DC Converter that accepts $24V_{IN}$ and generates a programmable output from 6.8V to -45V from a control voltage of 2.5V to approximately 0V respectively. The converter with the specified output filter provides 2mV PP output ripple. Additional features include under voltage shutdown, thermal protection, synchronization, and six-sided shielding.

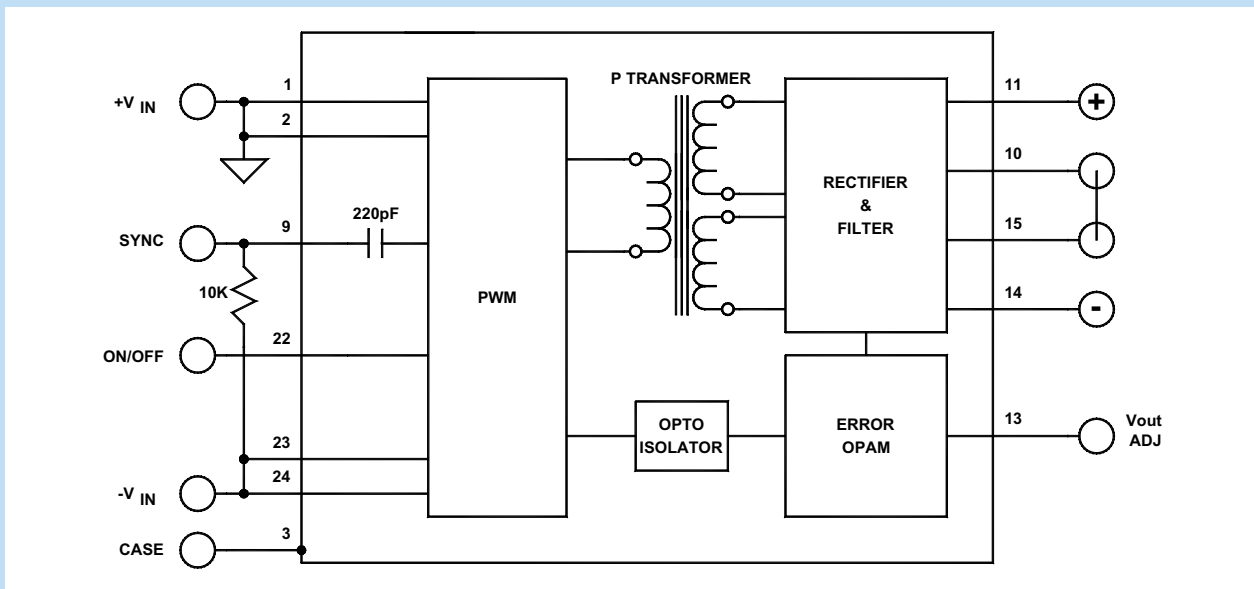

Typical Block Diagram

Electrical Specifications

INPUT SPECIFICATIONS

Unless otherwise specified, all parameters are given under typical +25°C with nominal input voltage and under full output load conditions.

PARAMETER	CONDITION / NOTE	MIN	TYP	MAX	UNIT
Input Voltage Range		20	24	26	Vdc
No Load Input Current			10		mA
Full Load Input Current			397		mA
Input Filter	C = 3.3 for 24V _{IN}				μF
Reverse Polarity	External series-blocking diode				
Reflected Ripple	I _O = FL, C _{IN} = 10μF, SEE APPROPRIATE CONNECTION DIAGRAM				
Input Surge Current (20μS Spike)			40	10	A
Short Circuit Current Limit	See Short Circuit Protection		150		% I _{IN}
Off State Current			1		mA
Remote ON/OFF Control					
Supply ON	Pin 22 Open (Open circuit voltage: 0V)				
Supply OFF	Pin 22	5	10	15	Vdc
Logic Input Reference	-Input for ON/OFF				

OUTPUT SPECIFICATIONS

PARAMETER	CONDITION / NOTE	MIN	TYP	MAX	UNIT
Output Voltage Range		-6.8		-45	Vdc
Output Voltage Accuracy			0.5	1	% of V _{OUT}
Ripple & Noise	With specified output filter		2	4	mV
Output Current			178		mA
Line Regulation			.5	±1	%
Load Regulation			.5	1	%
Temperature Coefficient @ FL			0.02		%/°C
Transient Response Time	50% FL to FL to 50% FL, C _O =3.3μF, See Figure 5		1	2	mS
Short Circuit Protection ¹	By input current limiting				
Output Adjust Range	input power may need to be recycled if the input overcurrent threshold is exceeded after a hard output short circuit				

GENERAL SPECIFICATIONS

PARAMETER	CONDITION / NOTE	MIN	TYP	MAX	UNIT
Efficiency	V = 55 @145mA		84		%
Isolation Voltage (1 min.), Input to Output			1000		Vdc
Isolation Resistance			10 ⁹		Ω
Isolation Capacitance			1000		pF
Switching Frequency			330		kHz
Turn On Delay	See Figure 2		2.5		mS
Soft Start Time	See Figure 2		8		mS

ENVIRONMENTAL SPECIFICATIONS

PARAMETER	CONDITION / NOTE	MIN	TYP	MAX	UNIT
Operating Temperature Range (Ambient), 24V	See Figure 1	-25		+60	°C
Storage Temperature Range		-60		+105	°C
Thermal Shutdown	Case temperature (Input power must be recycled)	96	100	104	°C
Thermal Resistance	Maximum case temperature is 36°C above ambient		36	43	°C/W
Derating	See Figure 1				
Humidity	Up to 95% non-condensing				
Cooling	Free-air convection				
MTBF	per MIL-HNBK-217F (Ground benign, +25°C)		1.3x10 ⁶		hours

PHYSICAL CHARACTERISTICS

PARAMETER	CONDITION / NOTE	MIN	TYP	MAX	UNIT
Dimensions (L×W×H)	1.25×0.80×0.40 in. (31.75×20.32×10.16mm)				
Weight	0.56 oz. (15.8g)				
Case Material	Coated metal				
Shielding	Six-sided continuous				
Case Connection					

MECHANICAL SPECIFICATIONS

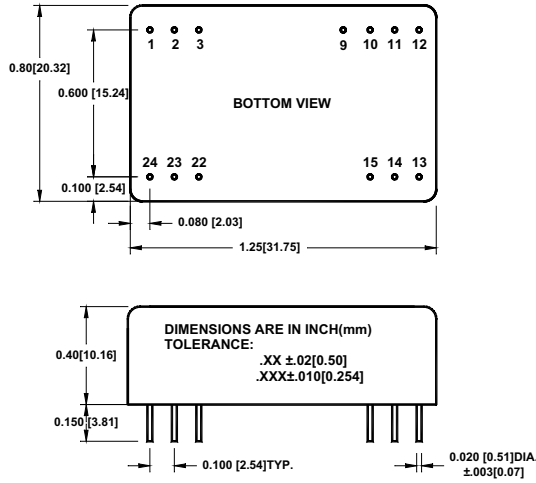

(Pin)	Function
1	+V _{IN}
2	+V _{IN}
3	CASE
9	SYNC
10	-V _{O1} (CONNECT TO PIN 15)
11	(+V _O)
12	No Pin
13	V _{OUT} ADJ
14	(-V _O)
15	+V _{O2} (CONNECT TO PIN 10)
22	ON/OFF
23	-V _{IN}
24	-V _{IN}

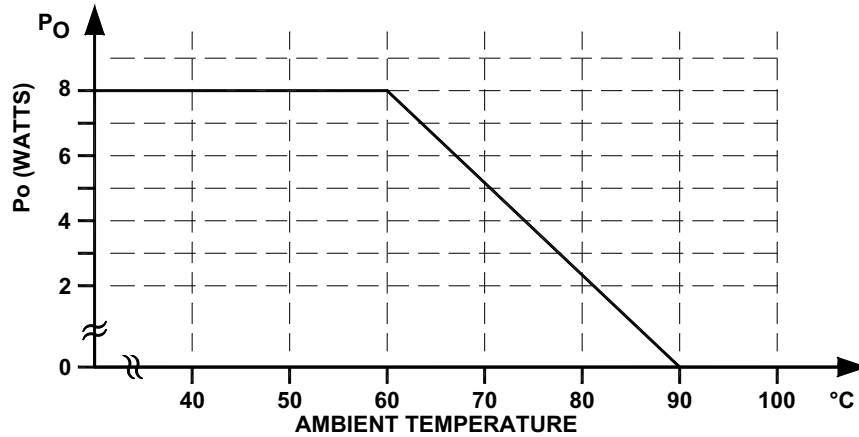

FIGURE 1. Typical derating curve of the M10001

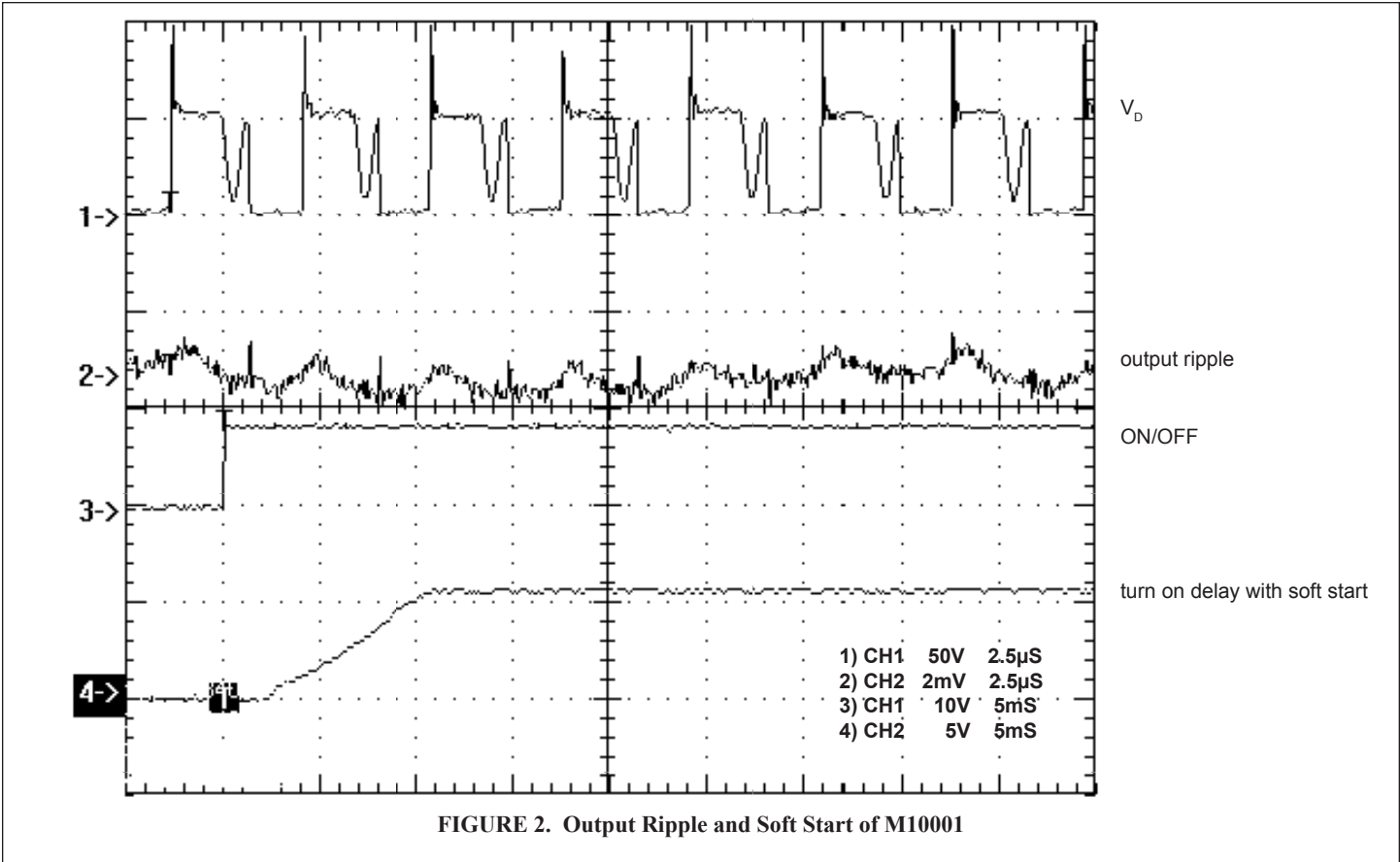

FIGURE 2. Output Ripple and Soft Start of M10001

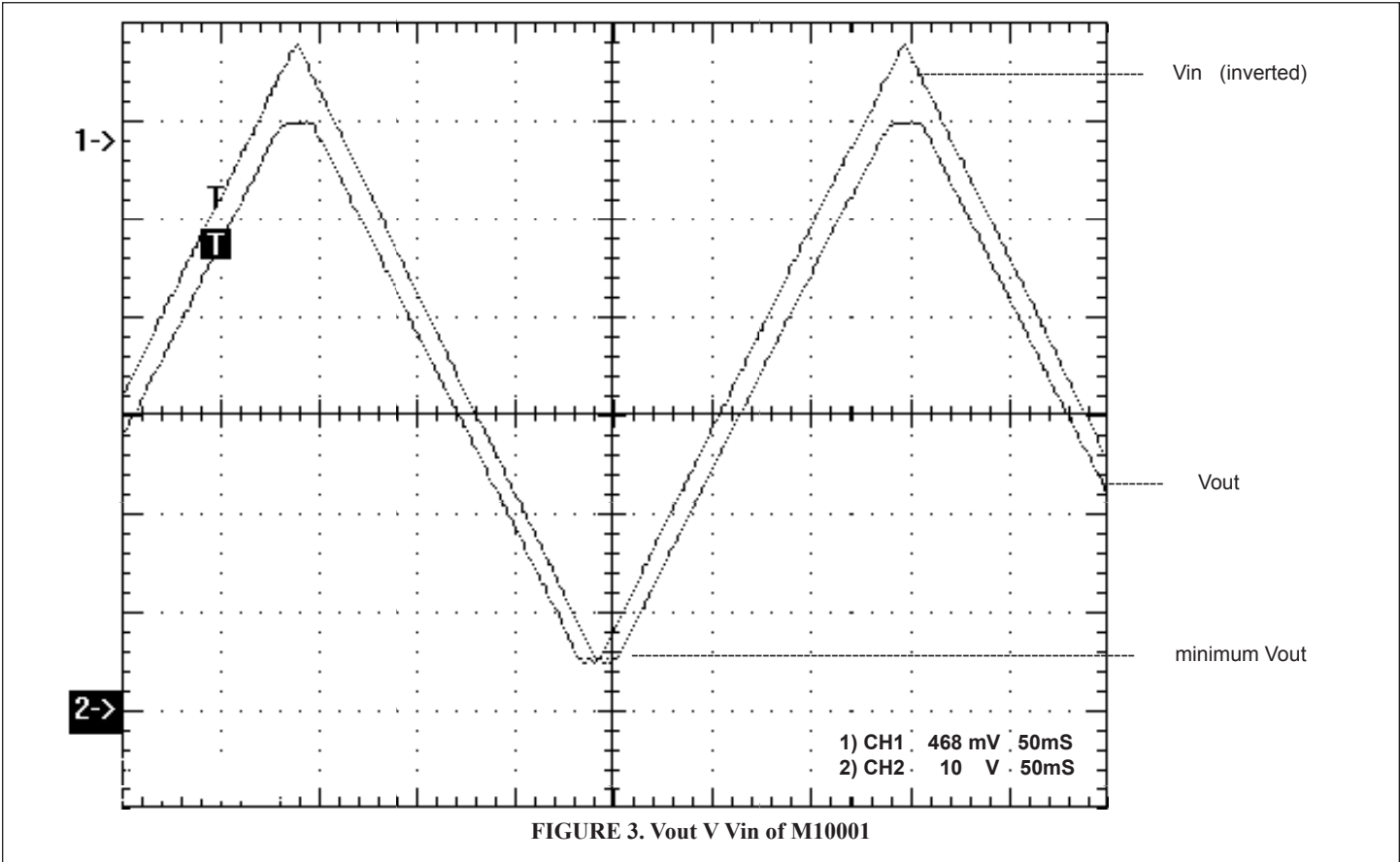
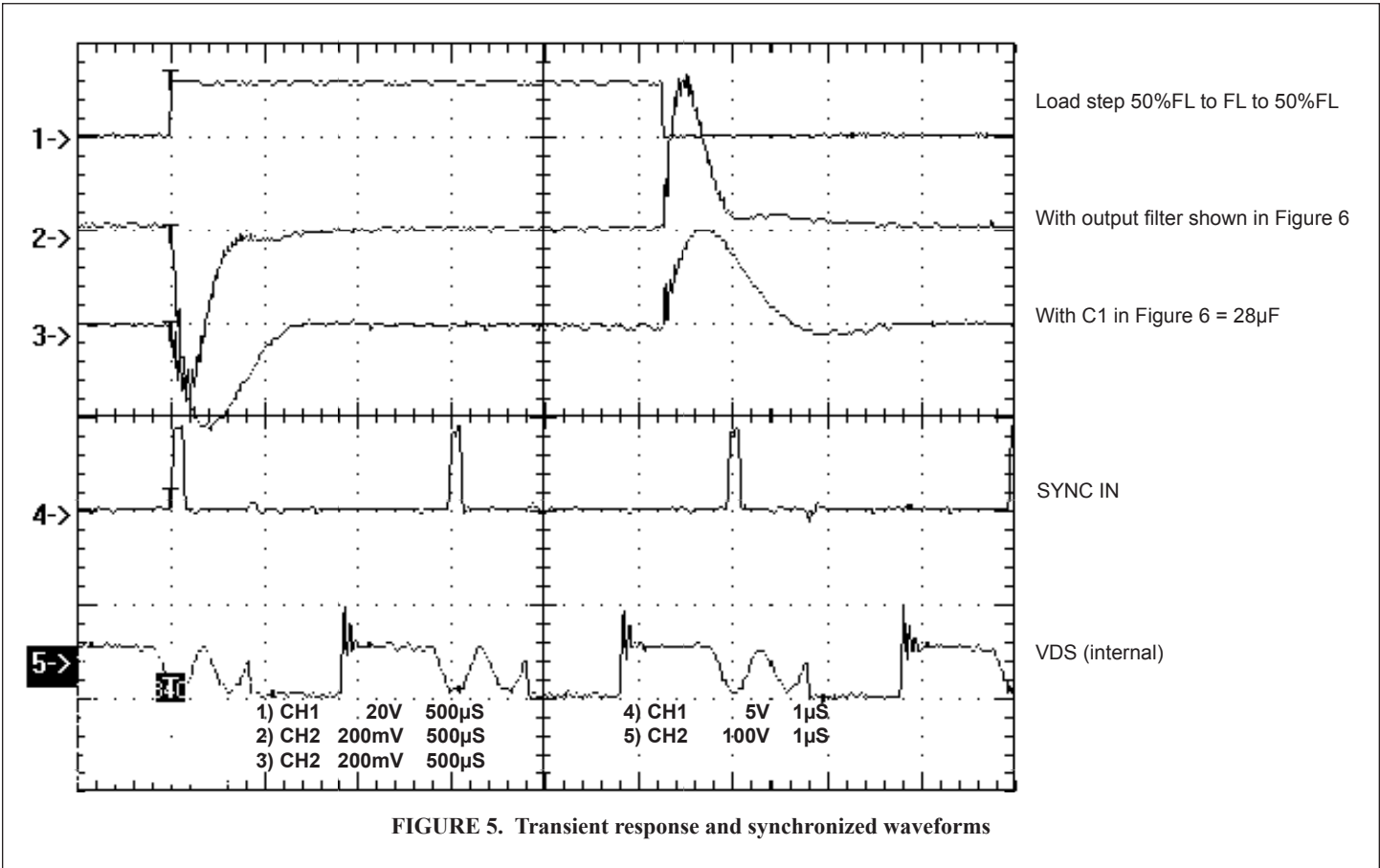
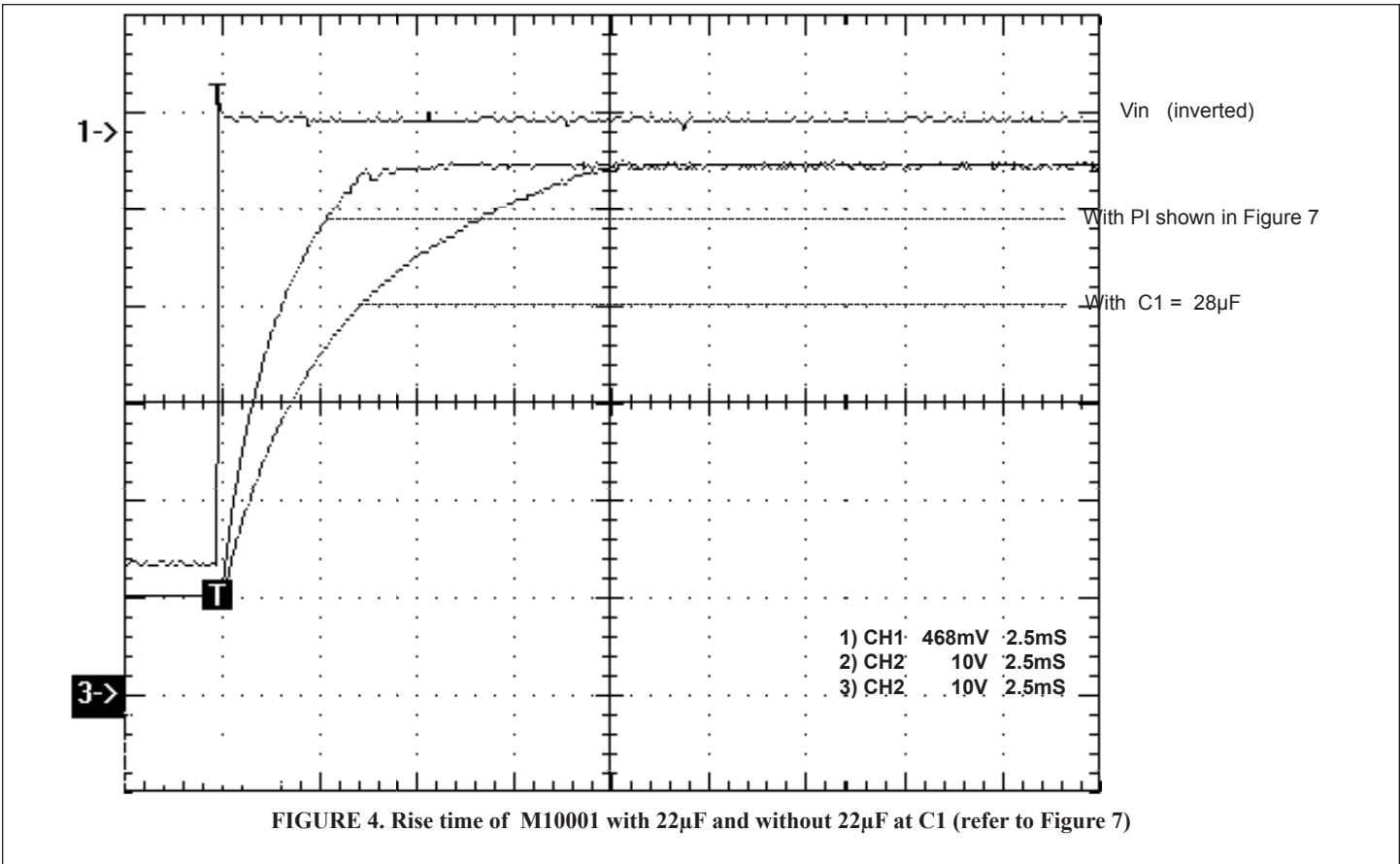

FIGURE 3. V_{out} V V_{in} of M10001



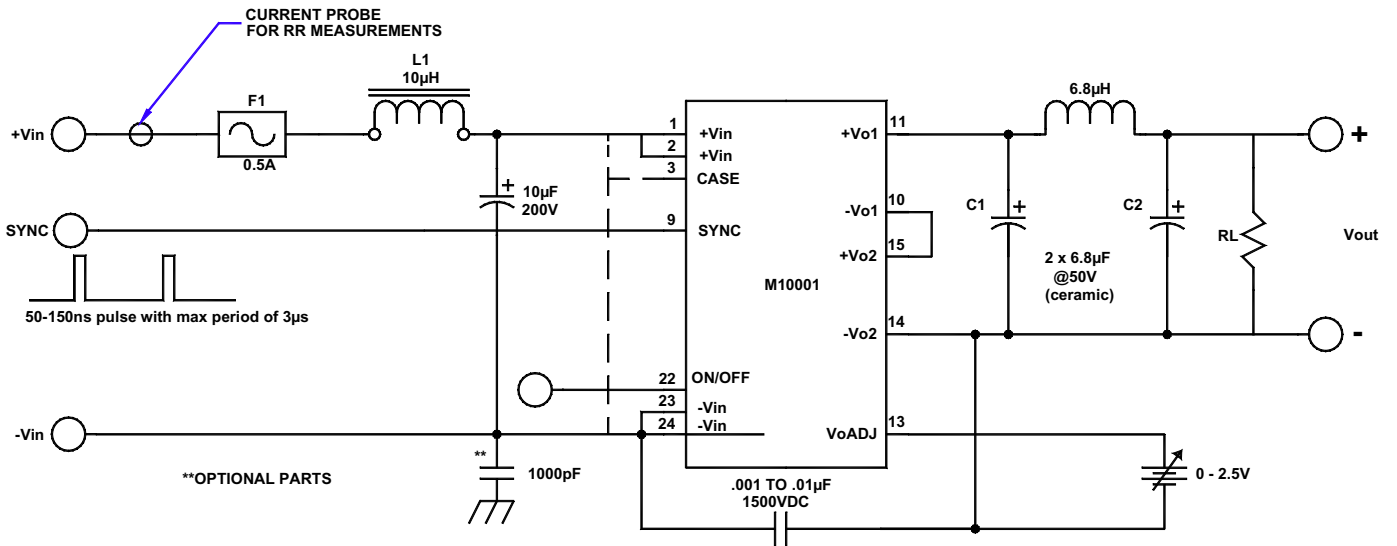

FIGURE 6. Typical connection diagram of M10001

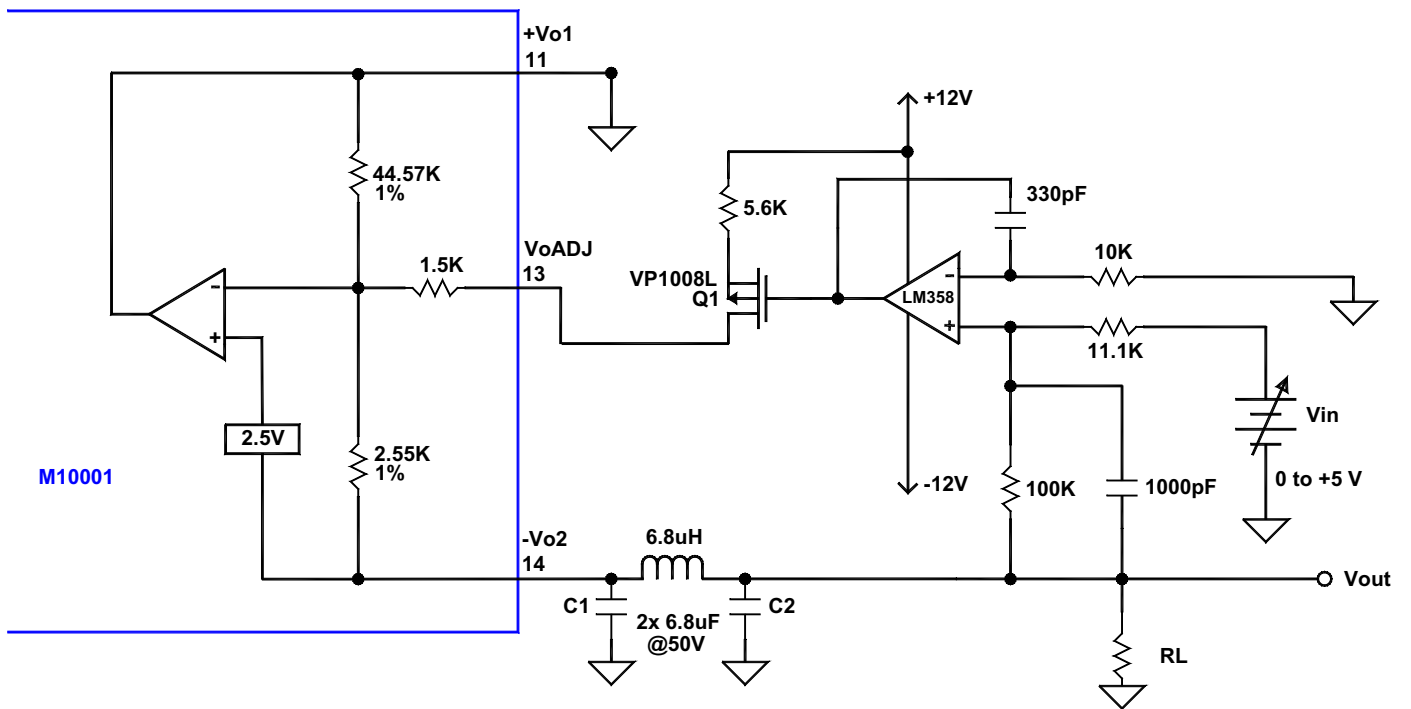

FIGURE 7. Connection diagram for M10001 for $V_{IN} = 0$ to 5V and $V_{OUT} = 6.8$ to 55V

EXTERNAL SYNCHRONIZATION

The converter can be synchronized to an external clock. The external clock MUST have a higher frequency than that of the converter's switching frequency. The amplitude of the external clock pulse must be 3.7 volts or greater and its duration between 50nS to 150nS for sync pulse detection.

The circuit in Figure 8 can be used to produce a 50nS to 150nS pulse from a square wave. The circuit will be turned on by the negative edge of the square wave and will stay on for approximately 50nS (depending on the $R2 \cdot C1$ time constant) (See Figure 9).

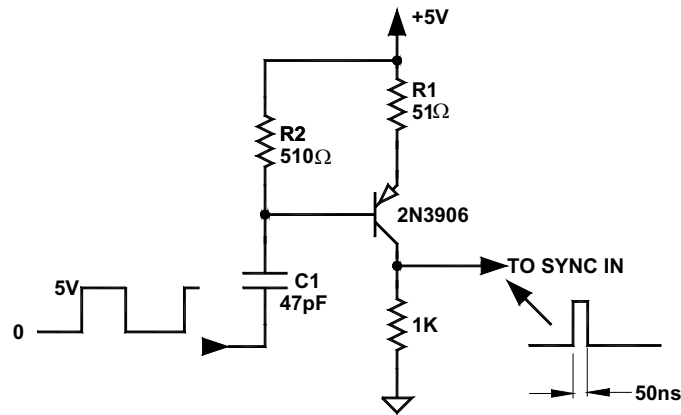

FIGURE 8. 50nS pulse generator from a square wave TTL/5V CMOS clock

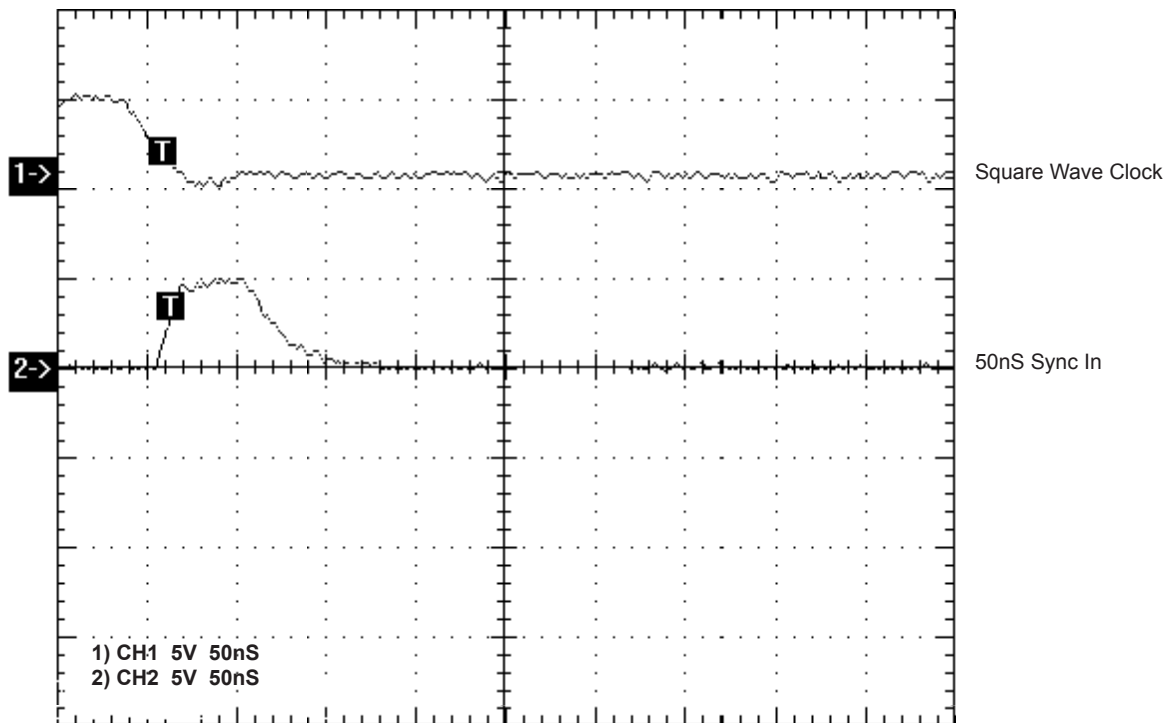

FIGURE 9. Waveforms generated from Figure 8