



## Q25011 25W DC/DC CONVERTER 2"×1"×0.45" 16-36Vin, 24Vout@1.05A

### Key Features

- Efficiency up to 87%
- Low output noise
- Six-sided shielding
- Output synchronous rectification
- Input-to-output isolation
- Soft start
- External synchronization
- Short circuit protection
- Thermal protection
- Industry standard pinout



Beta Dyne is protected under various patents, including but not limited to U.S. Patent numbers: 5,777,519; 6,188,276; 6,262,901; 6,452,818; 6,473,3171.

### Functional Description

The Q25011 is a single DC/DC converter that accepts 18-36Vin and provides 24Vout at 1.05 A. The converter is designed to synchronize to an external clock. Output synchronous rectification followed by a very low dropout linear regulator makes possible to achieve up to 87% efficiency with less than 20mV output noise with external capacitors. Standard features include input undervoltage protection, external synchronization and thermal protection. The converter is packaged in a 2 x 1 x .45" metal case with six-sided shielding.

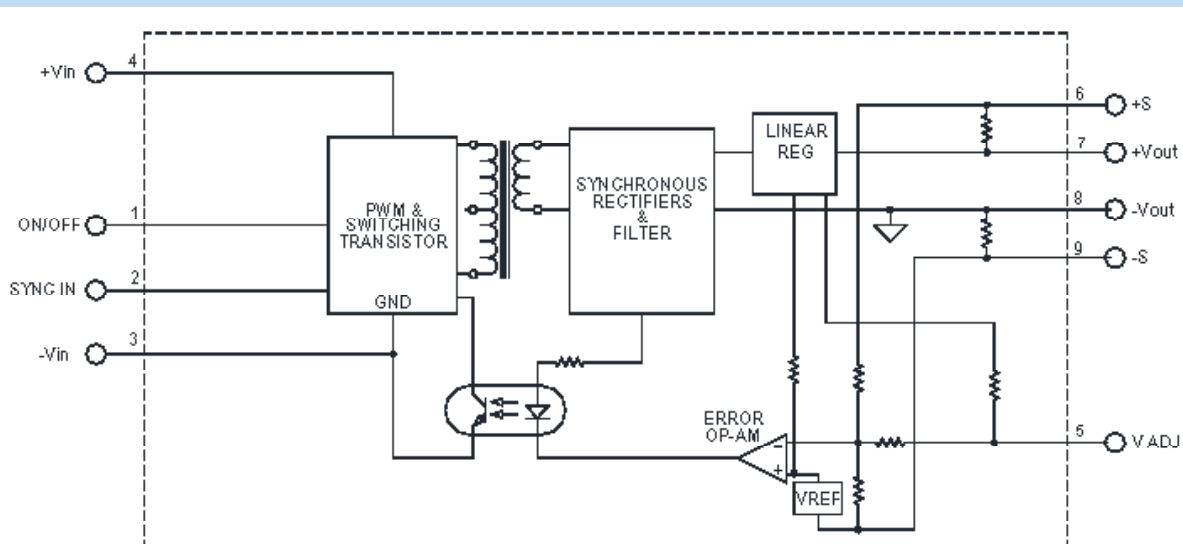

Typical Block Diagram

## Electrical Specifications

### INPUT SPECIFICATIONS

PARAMETER	CONDITION / NOTE	MIN	TYP	MAX	UNIT
Input Voltage Range		18	24	36	Vdc
Input Startup Voltage $24 V_{IN}$		15			Vdc
Overvoltage Shutdown $24 V_{IN}$		37			Vdc
Input Filter	Capacitor				
No Load Input Current			85		mA
Full Load Input Current	$V_{IN}=24V, I_{OUT}=1.05A$		1201		mA
Input Surge Current (20 $\mu$ S Spike)				10	A
Short Circuit Current Limit	120% Of $I_{IN}$ @ Full Load				
Off State Current			1.7		mA
Remote ON/OFF Control					
Supply ON	Pin 1 Open (Open circuit voltage: 10V Max.)				
Supply OFF	Pin 1 shorted to GND pin 3	0		0.6	Vdc
Logic Input Reference	To -Vin(GND ) pin 3				
Logic Compatability	TTL Open Collector or CMOS Open Drain				

### OUTPUT SPECIFICATIONS

PARAMETER	CONDITION / NOTE	MIN	TYP	MAX	UNIT
Voltage			24		Vdc
Output Voltage Accuracy			1		%
Output Current			1.05		A
Output Voltage Adjustment	See Figure 4		$\pm 5$	$\pm 10$	%
Ripple & Noise	For further reduction see Figure 6		20		mV
Line Regulation	Minimum $V_{IN}$ to maximum $V_{IN}$		$\pm 1$		%
Load Regulation	NL to FL		$\pm 1$		%
Temperature Coefficient @ FL			.01	.02	%/°C
Transient Response Time	50% FL to FL to 50% FL, See Figure 1	100			$\mu$ S
Short Circuit Protection	By Hiccup Technique				
Output Overvoltage Protection	None				

### GENERAL SPECIFICATIONS

PARAMETER	CONDITION / NOTE	MIN	TYP	MAX	UNIT
Efficiency (at full power)			87		%
Isolation Voltage (1 min.), Input to Output			1000		Vdc
Isolation Resistance			$10^9$		$\Omega$
Isolation Capacitance			300		pF
Switching Frequency ( $F_{SW}$ )			180		kHz
External Sync Frequency ( $F_E$ )	See Figure 1 & 2	195	200	210	kHz

### PHYSICAL CHARACTERISTICS

PARAMETER	CONDITION / NOTE	MIN	TYP	MAX	UNIT
Dimensions (L×W×H)	2.00×1.00×0.450 in. (50.80×25.40×11.43mm)				
Weight	1.3 oz. (37g)				

**ENVIRONMENTAL SPECIFICATIONS**

PARAMETER	CONDITION / NOTE	MIN	TYP	MAX	UNIT
Operating Temperature Range (Ambient)		-40		+71	°C
Storage Temperature Range		-55		+125	°C
Maximum Operating Case Temperature <sup>1</sup>				110	°C
MTBF	per MIL-HNBK-217F (Ground benign, +25°C)		1.1×10 <sup>6</sup>		hours
Shielding Connection	- V <sub>IN</sub> for 24 V <sub>IN</sub>				

**EXTERNAL SYNCHRONIZATION**

The SYNC pin can be used to synchronize the internal oscillator to external clock. An open drain output is the recommended interface between the external clock to the Q25 SYNC pin as shown in figure 1. The clock pulse width must be greater than 15ns. The external clock frequency must be greater than the frequency of the Q25.

Multiple Q25 converters can be synchronized together simply by connecting the converters SYNC pins together as shown in figure 2. Care should be taken to ensure the ground potential differences between the converters are minimized. In this configuration all the converters will be synchronized to the highest frequency device. The SYNC pin is a CMOS buffer with pull-up current limited to 200micro amps. If the external device forces the SYNC pin low before the internal oscillator ramp completes its charging cycle, the ramp will reset and another cycle begins. If the SYNC pins of multiple Q25 converters are connected together, the first SYNC pin that pulls low will reset the oscillator ramp of all the other converters. All converters will operate in phase when synchronized using the SYNC feature. Up to five devices can be synchronized using this method.

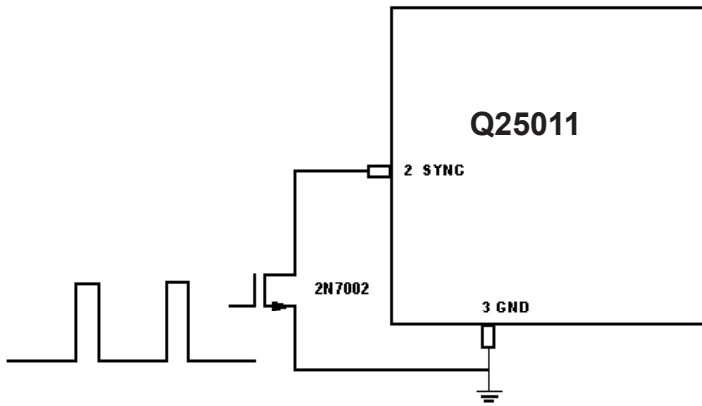

FIGURE 1. Sync from external clock

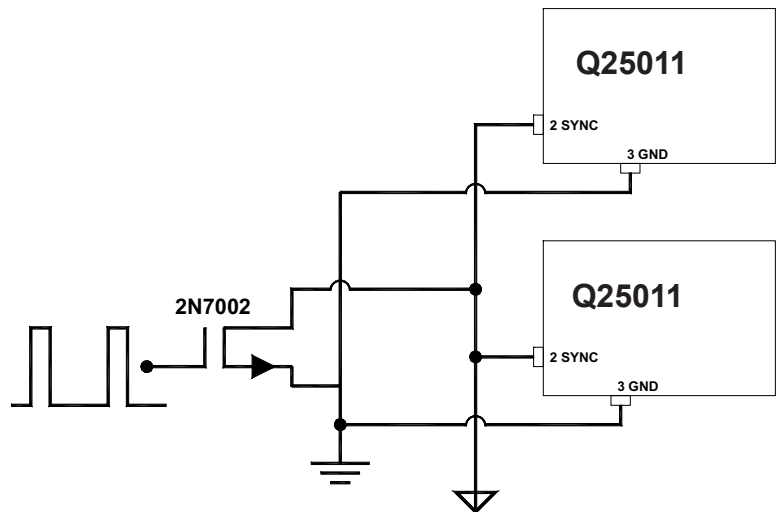

FIGURE 2. Sync of multiple devices

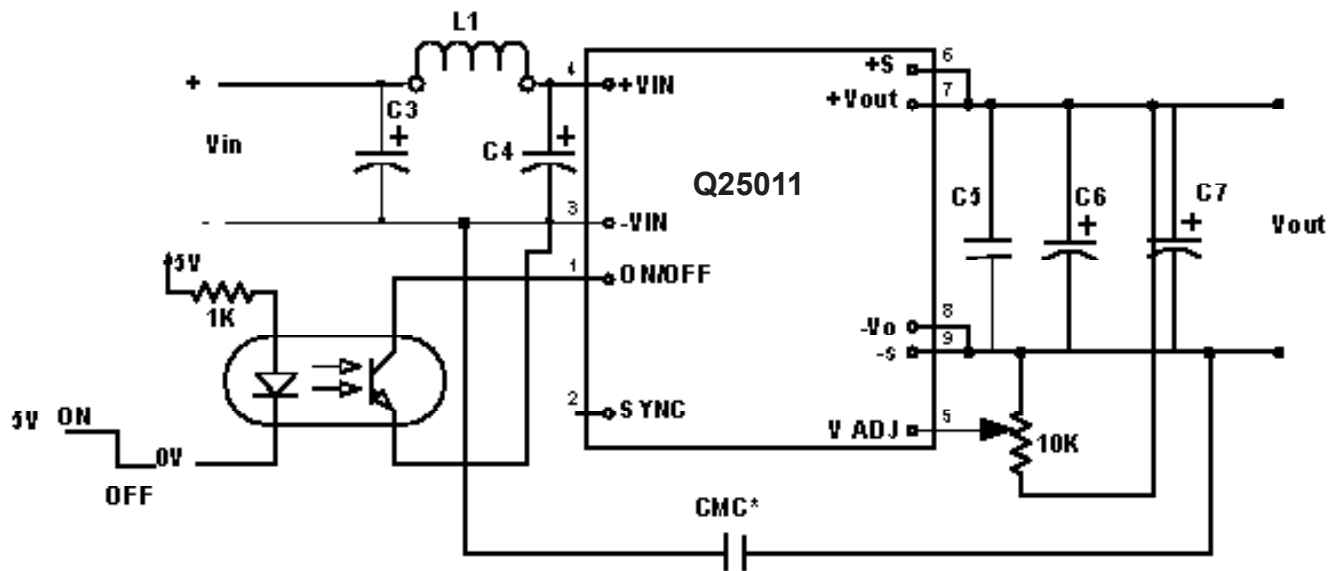
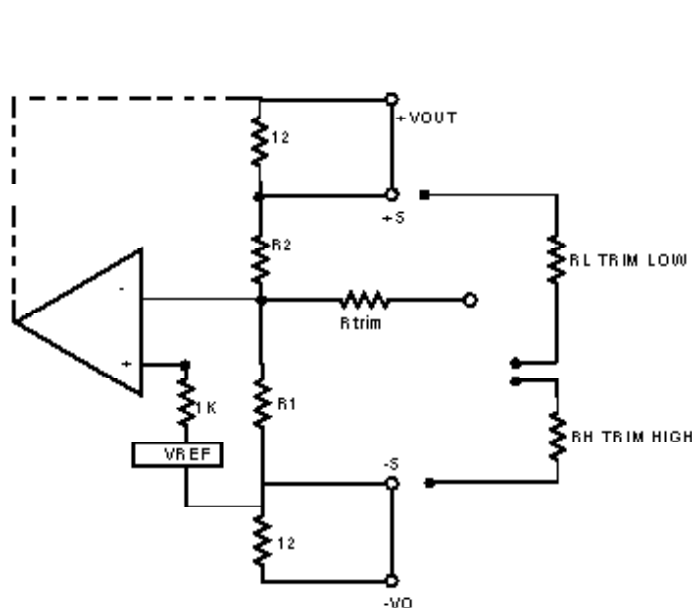

FIGURE 3. Typical connection diagram for Q25011 to further reduce output ripple.

Part list for Figure 3:

- L1= 2.2μH
- C3= 47μF@50V Electrolytic
- C4=47μF@50V Electrolytic
- C5= 1.5μF@25V Ceramic Capacitors
- C6=47μF@20V Low ESR Tantalum
- C7=180μF@16V Low ESR Tantalum

CMC\*=Common Mode Capacitor  
 CMC= .01μF@Vcmc  
 Vcmc >= than required isolation, voltage can be up to 1500V dc max.



$$R_L = \frac{(V_o - V_{ref})R_1 \cdot R_2}{V_{ref}(R_1 + R_2) - V_o R_1} \quad \text{--- } R_t \quad \text{in k}\Omega$$

$$R_H = \frac{R_1 \cdot R_2}{\left(\frac{V_o}{V_{ref}} - 1\right)R_1 - R_2} \quad \text{--- } R_t \quad \text{in k}\Omega$$

VO	VREF	R2	R1	Rtrim
24V	2.5	21.43K	2.49K	23.7K

FIGURE 4. Single Output adjustment equations.

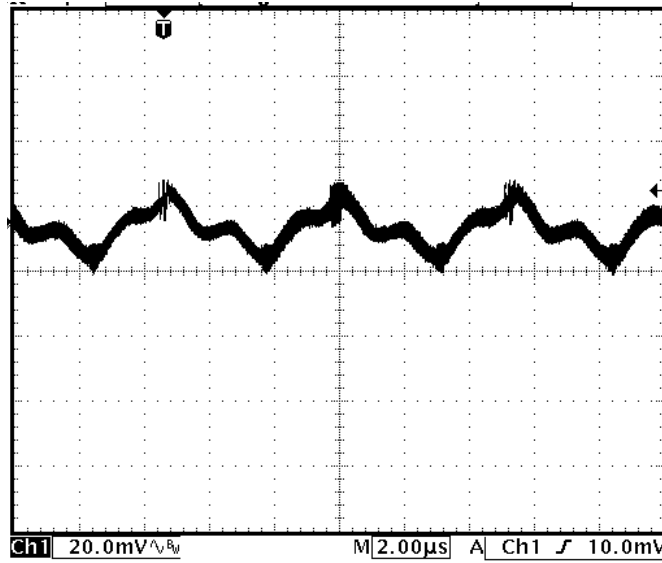

FIGURE 5. Output ripple of Q25011,  $V_{IN}=24V$ ,  $I_{OUT}=1.05A$ , no external output capacitor as shown in Figure 3.

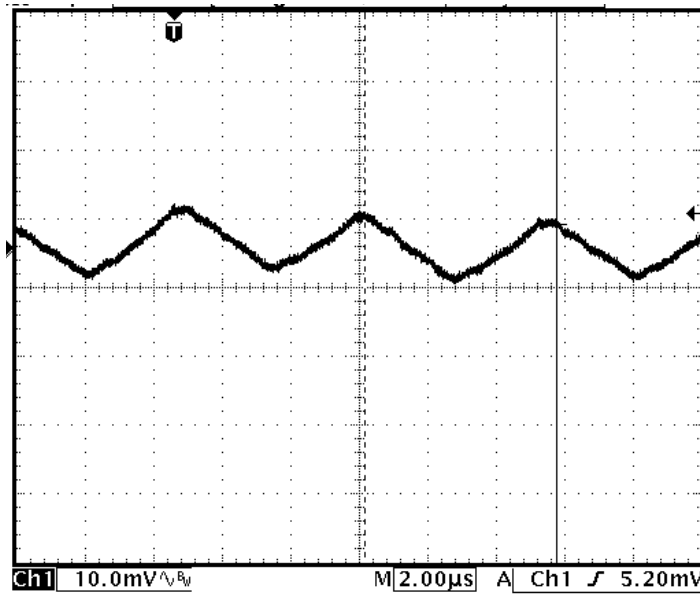

FIGURE 6. Output ripple of Q25011,  $V_{IN}=24V$ ,  $I_{OUT}=1.05A$ , with a 47µF with an external output capacitor as shown in Figure 3.

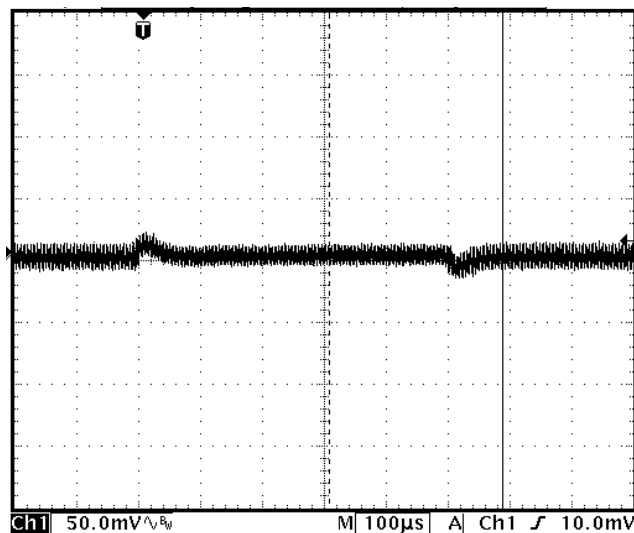
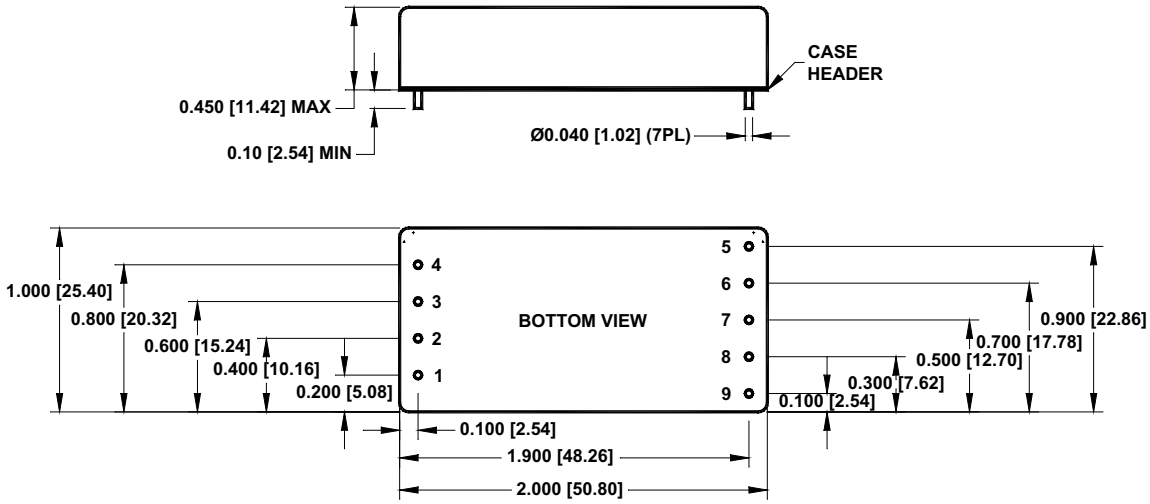

FIGURE 7. Transient response at  $V_{IN}=24V$ , when  $I_{OUT}$  is switching from Full Load to 1/2 Full Load to Full Load.

### MECHANICAL SPECIFICATIONS



Pin	Function
<b>SINGLE</b>	
<b>INPUT</b>	
1	ON/OFF
2	SYNC IN
3	-V <sub>IN</sub>
4	+V <sub>IN</sub>
<b>OUTPUT</b>	
5	V <sub>ADJ</sub>
6	+S
7	+V <sub>OUT</sub>
8	-V <sub>OUT</sub>
9	-S

DIMENSION ARE IN INCH(mm)  
 TOLERANCE: .XX ±.02(.508)  
 .XXX ±.01(.254)