



Q25015 21W DC/DC CONVERTER 36-72Vin, 14Vout@1.50A

Key Features

- Efficiency up to 89%
- Low output noise
- Six-sided shielding
- Output synchronous rectification
- Input-to-output isolation
- Soft start
- External synchronization
- Short circuit protection
- Thermal protection
- Industry standard pinout
- External clock synchronization of 393KHz



Beta Dyne is protected under various patents, including but not limited to U.S. Patent numbers: 5,777,519; 6,188,276; 6,262,901; 6,452,818; 6,473,3171.

Functional Description

The Q25015 is a single DC/DC converter that accepts 36-72 Vin and provides 14Vout at 1.50 A. The converter is designed to synchronize to an external clock to a frequency of 393KHz. Output synchronous rectification followed by a very low dropout linear regulator makes it possible to achieve up to 89% efficiency with less than 20mV output noise with external capacitors. Standard features include input undervoltage protection, external synchronization and thermal protection. The converter is packaged in a 2" x 1" x .45" metal case with six-sided shielding.

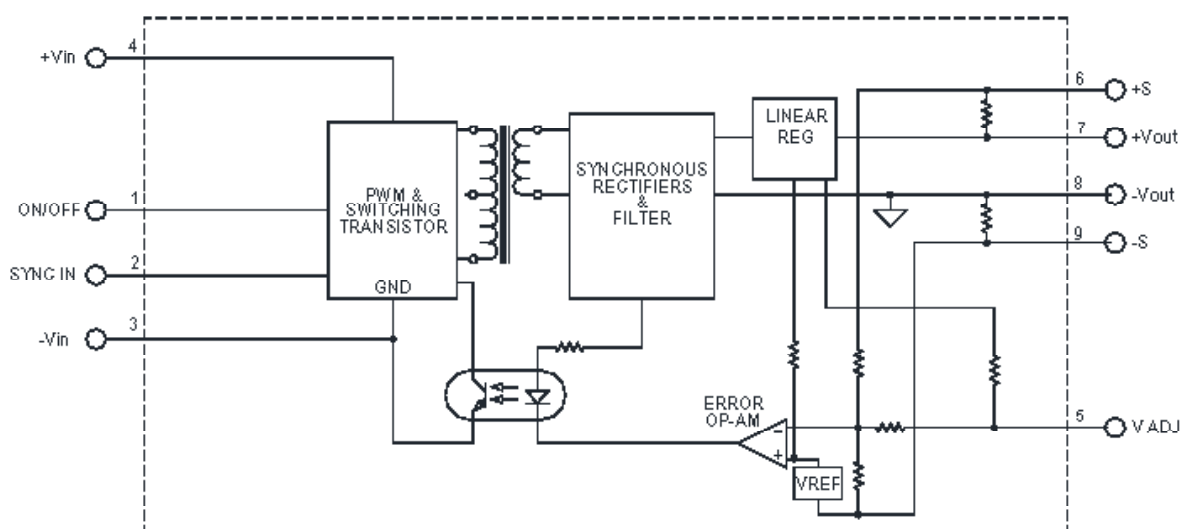

Typical Block Diagram

Electrical Specifications

INPUT SPECIFICATIONS

PARAMETER	CONDITION / NOTE	MIN	TYP	MAX	UNIT
Input Voltage Range		36	48	72	Vdc
Input Startup Voltage		33			Vdc
Input Overvoltage Shutdown		73			Vdc
Input Filter	Capacitor				
No Load Input Current			55		mA
Full Load Input Current			489		mA
Input Surge Current (20 μ S Spike)				10	A
Short Circuit Current Limit	120% Of I_{IN} @ Full Load				
Off State Current			20		μ A
Remote ON/OFF Control					
Supply ON	Pin 1 Open (Open circuit voltage: 10V Max.)				
Supply OFF	Pin 1 shorted to GND pin 3	0		0.6	Vdc
Logic Input Reference	To -Vin(GND) pin 3				
Logic Compatability	TTL Open Collector or CMOS Open Drain				

OUTPUT SPECIFICATIONS

PARAMETER	CONDITION / NOTE	MIN	TYP	MAX	UNIT
Voltage			14		Vdc
Output Voltage Accuracy			1		%
Output Current			1.50		A
Output Voltage Adjustment	See Figure 4		± 5	± 10	%
Ripple & Noise	For further reduction see Figure 3		20		mV
Line Regulation	Minimum V_{IN} to maximum V_{IN}		± 1		%
Load Regulation	NL to FL		± 1		%
Temperature Coefficient @ FL			.01	.02	%/ $^{\circ}$ C
Transient Response Time	50% FL to FL to 50% FL	100			μ S
Short Circuit Protection	By Hiccup Technique				
Output Overvoltage Protection	None				

GENERAL SPECIFICATIONS

PARAMETER	CONDITION / NOTE	MIN	TYP	MAX	UNIT
Efficiency (at full power)			89		%
Isolation Voltage (1 min.), Input to Output			1000		Vdc
Isolation Resistance			10^9		Ω
Isolation Capacitance			300		pF
Switching Frequency (F_{SW})			370		kHz
External Sync Frequency (F_E)	See Figure 1 & 2		393		kHz

PHYSICAL CHARACTERISTICS

PARAMETER	CONDITION / NOTE	MIN	TYP	MAX	UNIT
Dimensions (LxWxH)	2.00x1.00x0.450 in. (50.80x25.40x11.43mm)				
Weight	1.3 oz. (37g)				

ENVIRONMENTAL SPECIFICATIONS

PARAMETER	CONDITION / NOTE	MIN	TYP	MAX	UNIT
Operating Temperature Range (Ambient)		-40		+71	°C
Storage Temperature Range		-55		+125	°C
MTBF	per MIL-HNBK-217F (Ground benign, +25°C)		1.1×10 ⁶		hours
Shielding Connection	+ V _{IN} for 48V _{IN}				

EXTERNAL SYNCHRONIZATION

The SYNC pin can be used to synchronize the internal oscillator to external clock. An open drain output is the recommended interface between the external clock to the Q25015 SYNC pin as shown in figure 1. The clock pulse width must be greater than 15ns. The external clock frequency must be greater than the frequency of the Q25015.

Multiple Q25015 converters can be synchronized together simply by connecting the converters SYNC pins together as shown in figure 2. Care should be taken to ensure the ground potential differences between the converters are minimized. In this configuration all the converters will be synchronized to the highest frequency device. The SYNC pin is a CMOS buffer with pull-up current limited to 200micro amps. If the external device forces the SYNC pin low before the internal oscillator ramp completes its charging cycle, the ramp will reset and another cycle begins. If the SYNC pins of multiple Q25015 converters are connected together, the first SYNC pin that pulls low will reset the oscillator ramp of all the other converters. All converters will operate in phase when synchronized using the SYNC feature. Up to five devices can be synchronized using this method.

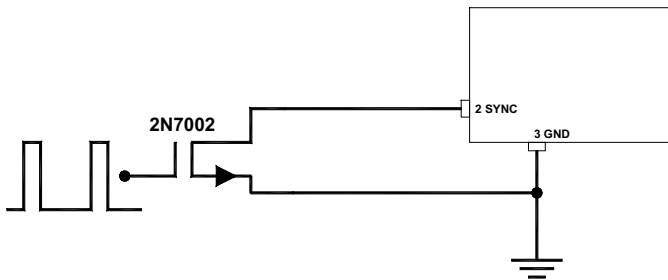

FIGURE 1. Sync from external clock for Q25015

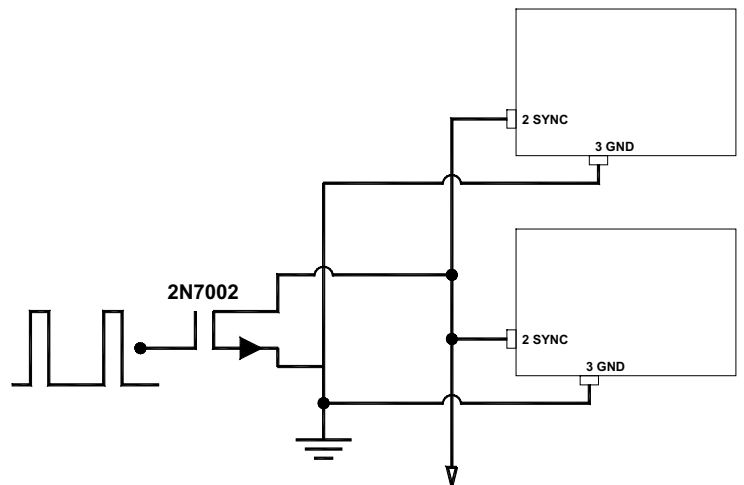

FIGURE 2. Sync of multiple devices of Q25015

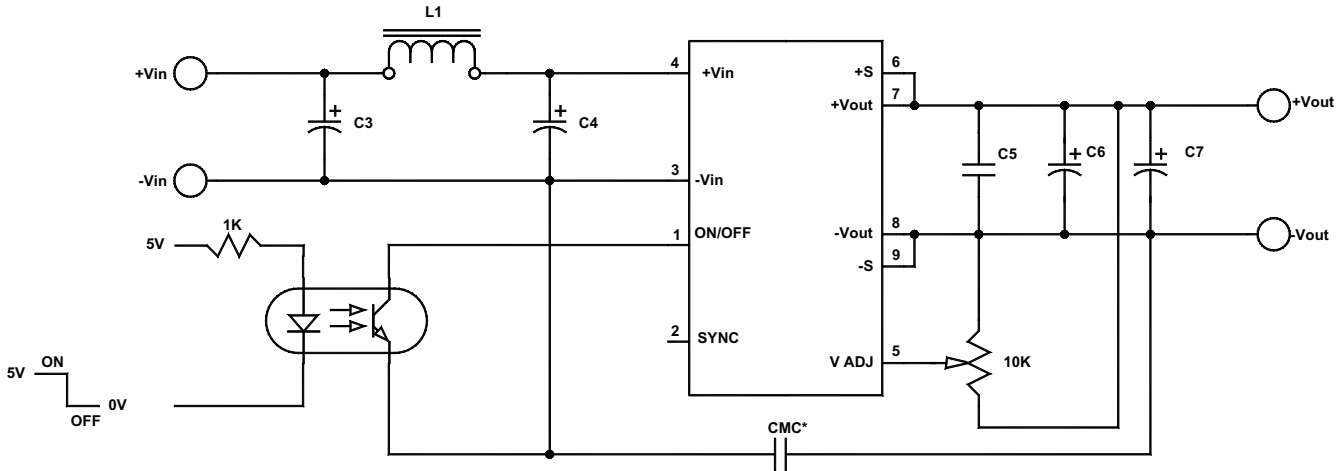

FIGURE 3. Typical connection diagram for Q25015 to further reduce output ripple.

Part list for Figure 3:

- L1= 2.2 μ H
- C3= 47 μ F@50V Electrolytic
- C4= 47 μ F@50V Electrolytic
- C5= 1.5 μ F@25V Ceramic Capacitors
- C6= 47 μ F@20V Low ESR Tantalum
- C7= 180 μ F@16V Low ESR Tantalum

CMC*= Common Mode Capacitor

CMC= .01 μ F@Vcmc

Vcmc >= than required isolation, voltage can be up to 1500V dc max.

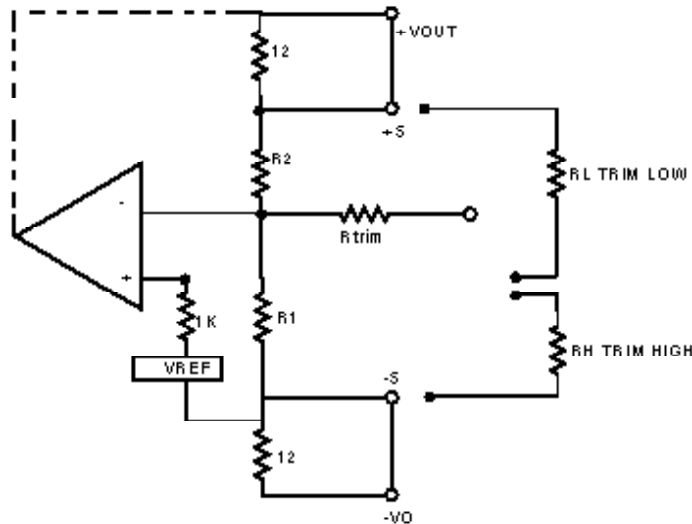

$$R_L = \frac{(V_o - V_{ref})R_1 \cdot R_2}{V_{ref}(R_1 + R_2) - V_o R_1} \quad \text{--- } R_t \quad \text{in k}\Omega$$

$$R_H = \frac{R_1 \cdot R_2}{\left(\frac{V_o}{V_{ref}} - 1\right)R_1 - R_2} \quad \text{--- } R_t \quad \text{in k}\Omega$$

VO	VREF	R2	R1	Rtrim
14V	2.5V	13.74K	3.01K	23.7K

FIGURE 4. Single output adjustment equations.

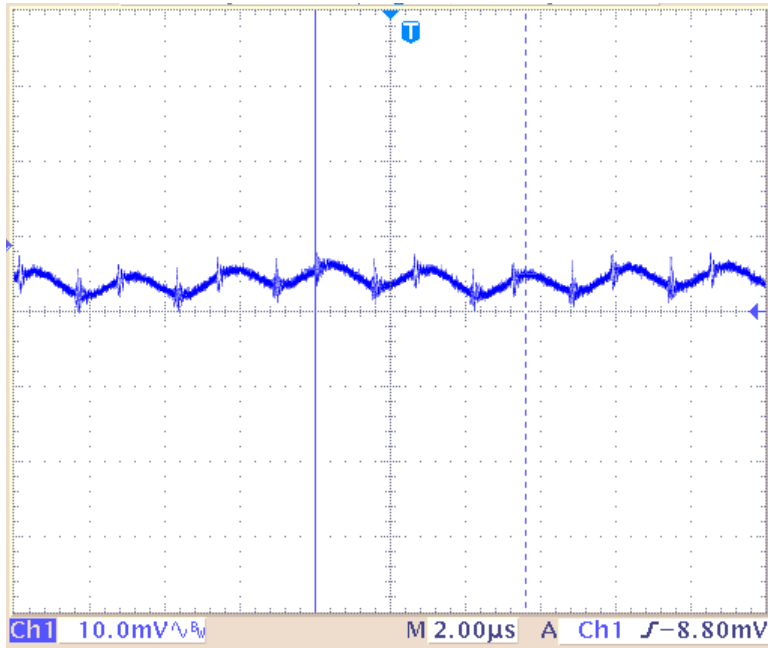
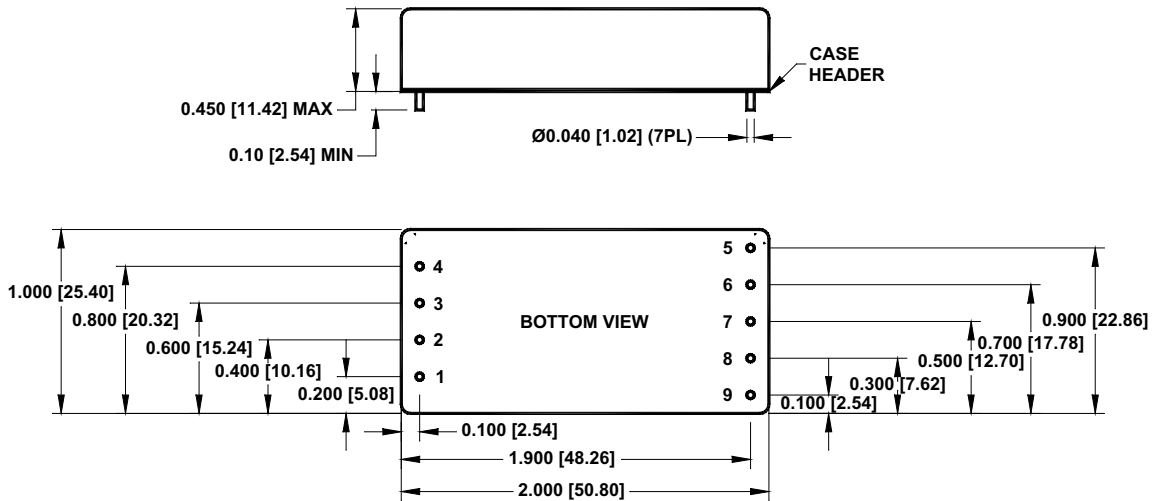

FIGURE 5. Output ripple of Q25015, $V_{IN}=48V$, $14V_{OUT}@I_{OUT}=1.5A$, as shown in Figure 3.

MECHANICAL SPECIFICATIONS



Pin	Function
SINGLE	
INPUT	
1	ON/OFF
2	SYNC IN
3	$-V_{IN}$
4	$+V_{IN}$
OUTPUT	
5	V_{ADJ}
6	$+S$
7	$+V_{OUT}$
8	$-V_{OUT}$
9	$-S$